

Chemistry

Part I

Textbook for Class XI



11082

विद्यया ऽ मृतमश्नुते



एन सी ई आर टी
NCERT

राष्ट्रीय शैक्षिक अनुसंधान और प्रशिक्षण परिषद्
NATIONAL COUNCIL OF EDUCATIONAL RESEARCH AND TRAINING

11082 – CHEMISTRY PART I

Textbook for Class XI

ISBN 81-7450-494-X (Part I)

81-7450-535-0 (Part II)

First Edition

March 2006 Phalguna 1927

Reprinted

October 2006 Kartika 1928
November 2007 Kartika 1929
January 2009 Magha 1930
December 2009 Pausa 1931
November 2010 Kartika 1932
January 2012 Pausha 1933
November 2012 Kartika 1934
November 2013 Kartika 1935
December 2014 Pausa 1936
May 2016 Vaishakha 1938
January 2018 Magha 1939
December 2018 Agrahayana 1940
October 2019 Ashwina 1941
July 2021 Asadha 1943
August 2022 Bhadrapada 1944

Revised Edition

October 2022 Ashwina 1944

PD 320T RSP

© National Council of Educational
Research and Training, 2006, 2022

₹ 180.00

Printed on 80 GSM paper with NCERT
watermark

Published at the Publication Division
by the Secretary, National Council of
Educational Research and Training,
Sri Aurobindo Marg, New Delhi 110 016
and printed at Educational Stores, S-5,
Bulandshahar Road, Industrial Area Site-I
(Near RTO Office) Ghaziabad (U.P.)

ALL RIGHTS RESERVED

- No part of this publication may be reproduced, stored in a retrieval system or transmitted, in any form or by any means, electronic, mechanical, photocopying, recording or otherwise without the prior permission of the publisher.
- This book is sold subject to the condition that it shall not, by way of trade, be lent, re-sold, hired out or otherwise disposed of without the publisher's consent, in any form of binding or cover other than that in which it is published.
- The correct price of this publication is the price printed on this page. Any revised price indicated by a rubber stamp or by a sticker or by any other means is incorrect and should be unacceptable.

OFFICES OF THE PUBLICATION DIVISION, NCERT

NCERT Campus
Sri Aurobindo Marg
New Delhi 110 016 Phone : 011-26562708

108, 100 Feet Road
Hosdakere Halli Extension
Banashankari III Stage
Bengaluru 560 085 Phone : 080-26725740

Navjivan Trust Building
P.O. Navjivan
Ahmedabad 380 014 Phone : 079-27541446

CWC Campus
Opp. Dhankal Bus Stop
Panihati
Kolkata 700 114 Phone : 033-25530454

CWC Complex
Maligaon
Guwahati 781 021 Phone : 0361-2674869

Publication Team

Head, Publication Division : Anup Kumar Rajput
Chief Production Officer : Arun Chitkara
Chief Business Manager : Vipin Dewan
Chief Editor (In charge) : Bijnan Sutar
Editor : Benoy Banerjee
Production Assistant : Om Prakash

Cover

Shweta Rao

Illustrations

Nidhi Wadhwa

Anil Nayal

FOREWORD

The National Curriculum Framework (NCF), 2005 recommends that children's life at school must be linked to their life outside the school. This principle marks a departure from the legacy of bookish learning which continues to shape our system and causes a gap between the school, home and community. The syllabi and textbooks developed on the basis of NCF signify an attempt to implement this basic idea. They also attempt to discourage rote learning and the maintenance of sharp boundaries between different subject areas. We hope these measures will take us significantly further in the direction of a child-centred system of education outlined in the National Policy on Education (1986).

The success of this effort depends on the steps that school principals and teachers will take to encourage children to reflect on their own learning and to pursue imaginative activities and questions. We must recognise that, given space, time and freedom, children generate new knowledge by engaging with the information passed on to them by adults. Treating the prescribed textbook as the sole basis of examination is one of the key reasons why other resources and sites of learning are ignored. Inculcating creativity and initiative is possible if we perceive and treat children as participants in learning, not as receivers of a fixed body of knowledge.

These aims imply considerable change in school routines and mode of functioning. Flexibility in the daily time-table is as necessary as rigour in implementing the annual calendar so that the required number of teaching days are actually devoted to teaching. The methods used for teaching and evaluation will also determine how effective this textbook proves for making children's life at school a happy experience, rather than a source of stress or boredom. Syllabus designers have tried to address the problem of curricular burden by restructuring and reorienting knowledge at different stages with greater consideration for child psychology and the time available for teaching. The textbook attempts to enhance this endeavour by giving higher priority and space to opportunities for contemplation and wondering, discussion in small groups, and activities requiring hands-on experience.

The National Council of Educational Research and Training (NCERT) appreciates the hard work done by the textbook development committee responsible for this book. We wish to thank the Chairperson of the advisory group in science and mathematics, Professor J.V. Narlikar and the Chief Advisor for this book, Professor B. L. Khandelwal for guiding the work of this committee. Several teachers contributed to the development of this textbook; we are grateful to their principals for making this possible. We are indebted to the institutions and organisations which have generously permitted us to draw upon their resources, material and personnel. As an organisation committed to systemic reform and continuous improvement in the quality of its products, NCERT welcomes comments and suggestions which will enable us to undertake further revision and refinement.

New Delhi
20 December 2005

Director
National Council of Educational
Research and Training

© NCERT
not to be republished

RATIONALISATION OF CONTENT IN THE TEXTBOOKS

In view of the COVID-19 pandemic, it is imperative to reduce content load on students. The National Education Policy 2020, also emphasises reducing the content load and providing opportunities for experiential learning with creative mindset. In this background, the NCERT has undertaken the exercise to rationalise the textbooks across all classes. Learning Outcomes already developed by the NCERT across classes have been taken into consideration in this exercise.

Contents of the textbooks have been rationalised in view of the following:

- Overlapping with similar content included in other subject areas in the same class
- Similar content included in the lower or higher class in the same subject
- Difficulty level
- Content, which is easily accessible to students without much interventions from teachers and can be learned by children through self-learning or peer-learning
- Content, which is irrelevant in the present context

This present edition, is a reformatted version after carrying out the changes given above.

© NCERT
not to be republished

TEXTBOOK DEVELOPMENT COMMITTEE

CHAIRPERSON, ADVISORY GROUP FOR TEXTBOOKS IN SCIENCE AND MATHEMATICS

J.V. Narlikar, *Emeritus Professor*, Chairman, Advisory Committee, Inter University Centre for Astronomy and Astrophysics (IUCCA), Ganeshbhind, Pune University, Pune

CHIEF ADVISOR

B.L. Khandelwal, *Professor (Retd.)*, *Emeritus Scientist*, CSIR; *Emeritus Fellow*, AICTE and formerly *Chairman*, Department of Chemistry, Indian Institute of Technology, New Delhi

MEMBERS

A. S. Brar, *Professor*, Indian Institute of Technology, Delhi

Anjni Koul, *Lecturer*, DESM, NCERT, New Delhi

H.O. Gupta, *Professor*, DESM, NCERT, New Delhi

I.P. Aggarwal, *Professor*, Regional Institute of Education, Bhopal

Jaishree Sharma, *Professor*, DESM, NCERT, New Delhi

M. Chandra, *Professor*, DESM, NCERT, New Delhi

Poonam Sawhney, *PGT (Chemistry)*, Kendriya Vidyalaya, Vikas Puri, New Delhi

R.K. Parashar, *Lecturer*, DESM, NCERT, New Delhi

S.K. Dogra, *Professor*, Dr. B.R. Ambedkar Centre for Biomedical Research, University of Delhi, Delhi

S.K. Gupta, *Reader*, School of Studies in Chemistry, Jiwaji University, Gwalior

Sadhna Bhargava, *PGT (Chemistry)*, Sardar Patel Vidyalaya, Lodhi Estate, New Delhi

Shubha Keshwan, *Headmistress*, Demonstration School, Regional Institute of Education, Mysuru

Sukhvir Singh, *Reader*, DESM, NCERT, New Delhi

Sunita Malhotra, *Professor*, School of Sciences, IGNOU, Maidan Garhi, New Delhi

V.K. Verma, *Professor (Retd.)*, Institute of Technology, Banaras Hindu University, Varanasi

V.P. Gupta, *Reader*, Regional Institute of Education, Bhopal

MEMBER-COORDINATOR

Alka Mehrotra, *Reader*, DESM, NCERT, New Delhi

ACKNOWLEDGEMENTS

The National Council of Educational Research and Training acknowledges the valuable contributions of the individuals and organisations involved in the development of Chemistry textbook for Class XI. It also acknowledges that some useful material from the reprint editions (2005) of Chemistry textbooks has been utilised in the development of the present textbook.

The following academics contributed effectively in editing, reviewing, refining and finalisation of the manuscript of this book: G.T. Bhandage, *Professor*, RIE, Mysuru; N. Ram, *Professor*, IIT, New Delhi; Sanjeev Kumar, *Associate Professor*, School of Science, IGNOU, Maidan Garhi, New Delhi; Shampa Bhattacharya, *Associate Professor*, Hans Raj College, Delhi; Vijay Sarada, *Associate Professor (Retd.)*, Zakir Husain College, New Delhi; K.K. Arora, *Associate Professor*, Zakir Husain College, New Delhi; Shashi Saxena, *Associate Professor*, Hans Raj College, Delhi; Anuradha Sen, Apeejay School, Sheikh Sarai, New Delhi; C. Shrinivas, *PGT*, Kendriya Vidyalaya, Pushp Vihar, New Delhi; D.L. Bharti, *PGT*, Ramjas School, Sector IV, R.K. Puram, New Delhi; Ila Sharma, *PGT*, Delhi Public School, Dwarka, Sector-B, New Delhi; Raj Lakshmi Karthikeyan, *Head (Science)*, Mother's International School, Sri Aurobindo Marg, New Delhi; Sushma Kiran Setia, *Principal*, Sarvodaya Kanya Vidyalaya, Hari Nagar (CT), New Delhi; Nidhi Chaudray, *PGT*, CRPF Public School, Rohini, Delhi; and Veena Suri, *PGT*, Bluebells School, Kailash Colony, New Delhi. We are thankful to them.

We express our gratitude to R.S. Sindhu, *Professor (Retd.)*, DESM, NCERT, New Delhi, for editing and refining the content of the textbook right from the initial stage.

We are also grateful to Ruchi Verma, *Associate Professor*, DESM, NCERT, New Delhi; Pramila Tanwar, *Associate Professor*, DESM, NCERT, New Delhi; R.B. Pareek, *Associate Professor*, RIE, Ajmer; and A.K. Arya, *Associate Professor*, RIE, Ajmer, for refining the content of the textbook.

Special thanks are due to M. Chandra, *Professor and Head (Retd.)*, DESM, NCERT for her support.

The Council also gratefully acknowledges the contributions of Surendra Kumar, Narender Verma and Ramesh Kumar, *DTP Operators*; Subhash Saluja, Ramendra Kumar Sharma and Abhimanyu Mohanty, *Proofreaders*; Bhavna Saxena, *Copy Editor*; and Deepak Kapoor, *In-charge*, Computer Station, in shaping this book. The contributions of the Publication Department, NCERT, New Delhi, in bringing out this book are also duly acknowledged.

CONTENTS

	Foreword	iii
	Rationalisation of Content in the Textbooks	v
Unit 1	Some Basic Concepts of Chemistry	1
	1.1 Importance of Chemistry	4
	1.2 Nature of Matter	4
	1.3 Properties of Matter and their Measurement	6
	1.4 Uncertainty in Measurement	10
	1.5 Laws of Chemical Combinations	14
	1.6 Dalton's Atomic Theory	16
	1.7 Atomic and Molecular Masses	16
	1.8 Mole Concept and Molar Masses	18
	1.9 Percentage Composition	18
	1.10 Stoichiometry and Stoichiometric Calculations	20
Unit 2	Structure of Atom	29
	2.1 Discovery of Sub-atomic Particles	30
	2.2 Atomic Models	32
	2.3 Developments Leading to the Bohr's Model of Atom	37
	2.4 Bohr's Model for Hydrogen Atom	46
	2.5 Towards Quantum Mechanical Model of the Atom	49
	2.6 Quantum Mechanical Model of Atom	53
Unit 3	Classification of Elements and Periodicity in Properties	74
	3.1 Why do we Need to Classify Elements ?	74
	3.2 Genesis of Periodic Classification	75
	3.3 Modern Periodic Law and the Present Form of the Periodic Table	78
	3.4 Nomenclature of Elements with Atomic Numbers > 100	78
	3.5 Electronic Configurations of Elements and the Periodic Table	81

(x)

3.6	Electronic Configurations and Types of Elements: <i>s</i> -, <i>p</i> -, <i>d</i> -, <i>f</i> - Blocks	82
3.7	Periodic Trends in Properties of Elements	85
Unit 4	Chemical Bonding and Molecular Structure	100
4.1	Kössel-Lewis Approach to Chemical Bonding	101
4.2	Ionic or Electrovalent Bond	106
4.3	Bond Parameters	107
4.4	The Valence Shell Electron Pair Repulsion (VSEPR) Theory	112
4.5	Valence Bond Theory	117
4.6	Hybridisation	120
4.7	Molecular Orbital Theory	125
4.8	Bonding in Some Homonuclear Diatomic Molecules	129
4.9	Hydrogen Bonding	131
Unit 5	Thermodynamics	136
5.1	Thermodynamic Terms	137
5.2	Applications	140
5.3	Measurement of ΔU and ΔH : Calorimetry	145
5.4	Enthalpy Change, $\Delta_r H$ of a Reaction – Reaction Enthalpy	146
5.5	Enthalpies for Different Types of Reactions	152
5.6	Spontaneity	157
5.7	Gibbs Energy Change and Equilibrium	162
Unit 6	Equilibrium	168
6.1	Equilibrium in Physical Processes	169
6.2	Equilibrium in Chemical Processes – Dynamic Equilibrium	172
6.3	Law of Chemical Equilibrium and Equilibrium Constant	174
6.4	Homogeneous Equilibria	177
6.5	Heterogeneous Equilibria	179
6.6	Applications of Equilibrium Constants	181
6.7	Relationship between Equilibrium Constant K , Reaction Quotient Q and Gibbs Energy G	184

(xi)

6.8 Factors Affecting Equilibria	184
6.9 Ionic Equilibrium in Solution	188
6.10 Acids, Bases and Salts	189
6.11 Ionization of Acids and Bases	192
6.12 Buffer Solutions	202
6.13 Solubility Equilibria of Sparingly Soluble Salts	204
Appendices	215
Answer to Some Selected Problems	229

© NCERT
not to be republished

THE CONSTITUTION OF INDIA

PREAMBLE

WE, THE PEOPLE OF INDIA, having solemnly resolved to constitute India into a ¹**[SOVEREIGN SOCIALIST SECULAR DEMOCRATIC REPUBLIC]** and to secure to all its citizens :

JUSTICE, social, economic and political;

LIBERTY of thought, expression, belief, faith and worship;

EQUALITY of status and of opportunity; and to promote among them all

FRATERNITY assuring the dignity of the individual and the ²[unity and integrity of the Nation];

IN OUR CONSTITUENT ASSEMBLY this twenty-sixth day of November, 1949 do **HEREBY ADOPT, ENACT AND GIVE TO OURSELVES THIS CONSTITUTION.**

1. Subs. by the Constitution (Forty-second Amendment) Act, 1976, Sec.2, for "Sovereign Democratic Republic" (w.e.f. 3.1.1977)
2. Subs. by the Constitution (Forty-second Amendment) Act, 1976, Sec.2, for "Unity of the Nation" (w.e.f. 3.1.1977)



11082CH01

UNIT 1

SOME BASIC CONCEPTS OF CHEMISTRY

Objectives

After studying this unit, you will be able to

- appreciate the contribution of India in the development of chemistry
- understand the role of chemistry in different spheres of life;
- explain the characteristics of three states of matter;
- classify different substances into elements, compounds and mixtures;
- use scientific notations and determine significant figures;
- differentiate between precision and accuracy;
- define SI base units and convert physical quantities from one system of units to another;
- explain various laws of chemical combination;
- appreciate significance of atomic mass, average atomic mass, molecular mass and formula mass;
- describe the terms – mole and molar mass;
- calculate the mass per cent of component elements constituting a compound;
- determine empirical formula and molecular formula for a compound from the given experimental data; and
- perform the stoichiometric calculations.

“*Chemistry is the science of molecules and their transformations. It is the science not so much of the one hundred elements but of the infinite variety of molecules that may be built from them.*”

Roald Hoffmann

Science can be viewed as a continuing human effort to systematise knowledge for describing and understanding nature. You have learnt in your previous classes that we come across diverse substances present in nature and changes in them in daily life. Curd formation from milk, formation of vinegar from sugarcane juice on keeping for prolonged time and rusting of iron are some of the examples of changes which we come across many times. For the sake of convenience, science is sub-divided into various disciplines: chemistry, physics, biology, geology, etc. The branch of science that studies the preparation, properties, structure and reactions of material substances is called chemistry.

DEVELOPMENT OF CHEMISTRY

Chemistry, as we understand it today, is not a very old discipline. Chemistry was not studied for its own sake, rather it came up as a result of search for two interesting things:

- Philosopher's stone (Paras)* which would convert all baser metals e.g., iron and copper into gold.
- 'Elixir of life'* which would grant immortality.

People in ancient India, already had the knowledge of many scientific phenomenon much before the advent of modern science. They applied that knowledge in various walks of life. Chemistry developed mainly in the form of Alchemy and Iatrochemistry during 1300-1600 CE. Modern chemistry took shape in the 18th century Europe, after a few centuries of alchemical traditions which were introduced in Europe by the Arabs.

Other cultures – especially the Chinese and the Indian – had their own alchemical traditions. These included much knowledge of chemical processes and techniques.

In ancient India, chemistry was called *Rasayan Shastra*, *Rastantra*, *Ras Kriya* or *Rasvidya*. It included metallurgy, medicine, manufacture of cosmetics, glass, dyes, etc. Systematic excavations at Mohenjodaro in Sindh and Harappa in Punjab prove that the story of development of chemistry in India is very old. Archaeological findings show that baked bricks were used in construction work. It shows the mass production of pottery, which can be regarded as the earliest chemical process, in which materials were mixed, moulded and subjected to heat by using fire to achieve desirable qualities. Remains of glazed pottery have been found in Mohenjodaro. Gypsum cement has been used in the construction work. It contains lime, sand and traces of CaCO_3 . Harappans made faience, a sort of glass which was used in ornaments. They melted and forged a variety of objects from metals, such as lead, silver, gold and copper. They improved the hardness of copper for making artefacts by using tin and arsenic. A number of glass objects were found in Maski in South India (1000–900 BCE), and Hastinapur and Taxila in North India (1000–200 BCE). Glass and glazes were coloured by addition of colouring agents like metal oxides.

Copper metallurgy in India dates back to the beginning of chalcolithic cultures in the subcontinent. There are much archeological evidences to support the view that technologies for extraction of copper and iron were developed indigenously.

According to *Rigveda*, tanning of leather and dying of cotton were practised during 1000–400 BCE. The golden gloss of the black polished ware of northern India could not be replicated and is still a chemical mystery. These wares indicate the mastery with which kiln temperatures could be controlled. Kautilya's *Arthashastra* describes the production of salt from sea.

A vast number of statements and material described in the ancient Vedic literature can

be shown to agree with modern scientific findings. Copper utensils, iron, gold, silver ornaments and terracotta discs and painted grey pottery have been found in many archaeological sites in north India. *Sushruta Samhita* explains the importance of Alkalies. The *Charaka Samhita* mentions ancient Indians who knew how to prepare sulphuric acid, nitric acid and oxides of copper, tin and zinc; the sulphates of copper, zinc and iron and the carbonates of lead and iron.

Rasopanishada describes the preparation of gunpowder mixture. Tamil texts also describe the preparation of fireworks using sulphur, charcoal, saltpetre (i.e., potassium nitrate), mercury, camphor, etc.

Nagarjuna was a great Indian scientist. He was a reputed chemist, an alchemist and a metallurgist. His work *Rasratnakar* deals with the formulation of mercury compounds. He has also discussed methods for the extraction of metals, like gold, silver, tin and copper. A book, *Rsarnavam*, appeared around 800 CE. It discusses the uses of various furnaces, ovens and crucibles for different purposes. It describes methods by which metals could be identified by flame colour.

Chakrapani discovered mercury sulphide. The credit for inventing soap also goes to him. He used mustard oil and some alkalies as ingredients for making soap. Indians began making soaps in the 18th century CE. Oil of *Eranda* and seeds of *Mahua* plant and calcium carbonate were used for making soap.

The paintings found on the walls of Ajanta and Ellora, which look fresh even after ages, testify to a high level of science achieved in ancient India. Varāhmihir's *Brihat Samhita* is a sort of encyclopaedia, which was composed in the sixth century CE. It informs about the preparation of glutinous material to be applied on walls and roofs of houses and temples. It was prepared entirely from extracts of various plants, fruits, seeds and barks, which were concentrated by boiling, and then, treated with various resins. It will be interesting to test such materials scientifically and assess them for use.

A number of classical texts, like *Atharvaveda* (1000 BCE) mention some dye stuff, the material used were turmeric, *madder*, sunflower, orpiment, cochineal and lac. Some other substances having tinting property were *kamplcica*, *pattanga* and *jatuka*.

Varāhmihir's *Brihat Samhita* gives references to perfumes and cosmetics. Recipes for hair dying were made from plants, like indigo and minerals like iron power, black iron or steel and acidic extracts of sour rice gruel. *Gandhayukli* describes recipes for making scents, mouth perfumes, bath powders, incense and talcum powder.

Paper was known to India in the 17th century as account of Chinese traveller I-tsing describes. Excavations at Taxila indicate that ink was used in India from the fourth century. Colours of ink were made from chalk, red lead and minimum.

It seems that the process of fermentation was well-known to Indians. Vedas and Kautilya's *Arthashastra* mention about many types of liquors. *Charaka Samhita* also mentions ingredients, such as barks of plants, stem, flowers, leaves, woods, cereals, fruits and sugarcane for making *Asavas*.

The concept that matter is ultimately made of indivisible building blocks, appeared in India a few centuries BCE as a part of philosophical speculations. Acharya Kanda, born in 600 BCE, originally known by the name Kashyap, was the first proponent of the 'atomic theory'. He formulated the theory of very small indivisible particles, which he named '*Paramānu*' (comparable to atoms). He authored the text *Vaisesika Sutras*. According to him, all substances are aggregated form of smaller units called atoms (*Paramānu*), which are eternal, indestructible, spherical, suprasensible and in motion in the original state. He explained that this individual entity cannot be sensed through any human organ. Kanda added that there are varieties of atoms that are as different as the different classes of substances. He said these (*Paramānu*) could form pairs or triplets, among other combinations and unseen

forces cause interaction between them. He conceptualised this theory around 2500 years before John Dalton (1766-1844).

Charaka Samhita is the oldest Ayurvedic epic of India. It describes the treatment of diseases. The concept of reduction of particle size of metals is clearly discussed in *Charaka Samhita*. Extreme reduction of particle size is termed as nanotechnology. *Charaka Samhita* describes the use of *bhasma* of metals in the treatment of ailments. Now-a-days, it has been proved that *bhasmas* have nanoparticles of metals.

After the decline of alchemy, Iatrochemistry reached a steady state, but it too declined due to the introduction and practise of western medicinal system in the 20th century. During this period of stagnation, pharmaceutical industry based on Ayurveda continued to exist, but it too declined gradually. It took about 100-150 years for Indians to learn and adopt new techniques. During this time, foreign products poured in. As a result, indigenous traditional techniques gradually declined. Modern science appeared in Indian scene in the later part of the nineteenth century. By the mid-nineteenth century, European scientists started coming to India and modern chemistry started growing.

From the above discussion, you have learnt that chemistry deals with the composition, structure, properties and interaction of matter and is of much use to human beings in daily life. These aspects can be best described and understood in terms of basic constituents of matter that are **atoms** and **molecules**. That is why, chemistry is also called the science of atoms and molecules. Can we see, weigh and perceive these entities (atoms and molecules)? Is it possible to count the number of atoms and molecules in a given mass of matter and have a quantitative relationship between the mass and the number of these particles? We will get the answer of some of these questions in this Unit. We will further describe how physical properties of matter can be quantitatively described using numerical values with suitable units.

1.1 IMPORTANCE OF CHEMISTRY

Chemistry plays a central role in science and is often intertwined with other branches of science.

Principles of chemistry are applicable in diverse areas, such as weather patterns, functioning of brain and operation of a computer, production in chemical industries, manufacturing fertilisers, alkalis, acids, salts, dyes, polymers, drugs, soaps, detergents, metals, alloys, etc., including new material.

Chemistry contributes in a big way to the national economy. It also plays an important role in meeting human needs for food, healthcare products and other material aimed at improving the quality of life. This is exemplified by the large-scale production of a variety of fertilisers, improved variety of pesticides and insecticides. Chemistry provides methods for the isolation of life-saving drugs from natural sources and makes possible synthesis of such drugs. Some of these drugs are **cisplatin** and **taxol**, which are effective in cancer therapy. The drug AZT (Azidothymidine) is used for helping AIDS patients.

Chemistry contributes to a large extent in the development and growth of a nation. With a better understanding of chemical principles it has now become possible to design and synthesise new material having specific magnetic, electric and optical properties. This has led to the production of superconducting ceramics, conducting polymers, optical fibres, etc. Chemistry has helped in establishing industries which manufacture utility goods, like acids, alkalies, dyes, polymers, metals, etc. These industries contribute in a big way to the economy of a nation and generate employment.

In recent years, chemistry has helped in dealing with some of the pressing aspects of environmental degradation with a fair degree of success. Safer alternatives to environmentally hazardous refrigerants, like CFCs (chlorofluorocarbons), responsible for ozone depletion in the stratosphere, have been successfully synthesised. However,

many big environmental problems continue to be matters of grave concern to the chemists. One such problem is the management of the Green House gases, like methane, carbon dioxide, etc. Understanding of biochemical processes, use of enzymes for large-scale production of chemicals and synthesis of new exotic material are some of the intellectual challenges for the future generation of chemists. A developing country, like India, needs talented and creative chemists for accepting such challenges. To be a good chemist and to accept such challenges, one needs to understand the basic concepts of chemistry, which begin with the concept of matter. Let us start with the nature of matter.

1.2 NATURE OF MATTER

You are already familiar with the term **matter** from your earlier classes. Anything which has mass and occupies space is called **matter**. Everything around us, for example, book, pen, pencil, water, air, all living beings, etc., are composed of matter. You know that they have mass and they occupy space. Let us recall the characteristics of the states of matter, which you learnt in your previous classes.

1.2.1 States of Matter

You are aware that matter can exist in three physical states *viz.* **solid**, **liquid** and **gas**. The constituent particles of matter in these three states can be represented as shown in Fig. 1.1.

Particles are held very close to each other in **solids** in an orderly fashion and there is not much freedom of movement. In **liquids**, the particles are close to each other but they can move around. However, in **gases**, the particles are far apart as compared to those present in solid or liquid states and their movement is easy and fast. Because of such arrangement of particles, different states of matter exhibit the following characteristics:

- (i) Solids have *definite volume* and *definite shape*.
- (ii) Liquids have *definite volume* but *do not have definite shape*. They take the shape of the container in which they are placed.

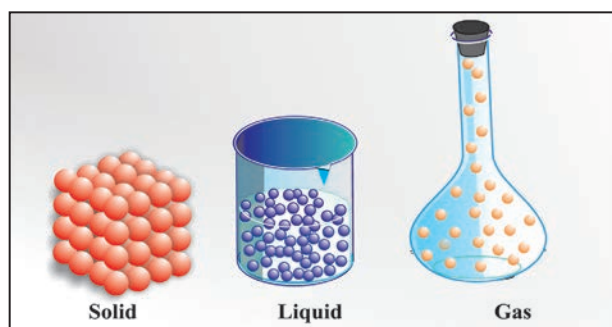

Fig. 1.1 Arrangement of particles in solid, liquid and gaseous state

- (iii) Gases have *neither definite volume nor definite shape*. They completely occupy the space in the container in which they are placed.

These three states of matter are interconvertible by changing the conditions of temperature and pressure.



On heating, a solid usually changes to a liquid, and the liquid on further heating changes to gas (or vapour). In the reverse process, a gas on cooling liquifies to the liquid and the liquid on further cooling freezes to the solid.

1.2.2. Classification of Matter

In Class IX (Chapter 2), you have learnt that at the macroscopic or bulk level, matter can be classified as **mixture** or **pure substance**. These can be further sub-divided as shown in Fig. 1.2.

When all constituent particles of a substance are same in chemical nature, it is said to be a pure substance. A mixture contains many types of particles.

A mixture contains particles of two or more pure substances which may be present in it in any ratio. Hence, their composition is variable. Pure substances forming mixture are called its components. Many of the substances present around you are **mixtures**. For example, sugar solution in water, air, tea, etc., are all mixtures. A mixture may be **homogeneous** or **heterogeneous**. In a **homogeneous mixture**, the components

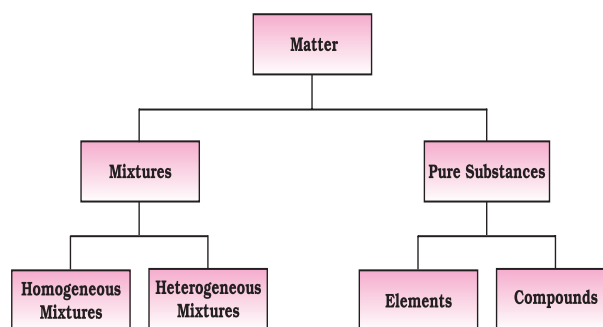

Fig. 1.2 Classification of matter

completely mix with each other. This means particles of components of the mixture are uniformly distributed throughout the bulk of the mixture and its composition is uniform throughout. Sugar solution and air are the examples of homogeneous mixtures. In contrast to this, in a **heterogeneous mixture**, the composition is not uniform throughout and sometimes different components are visible. For example, mixtures of salt and sugar, grains and pulses along with some dirt (often stone pieces), are heterogeneous mixtures. You can think of many more examples of mixtures which you come across in the daily life. It is worthwhile to mention here that the components of a mixture can be separated by using physical methods, such as simple hand-picking, filtration, crystallisation, distillation, etc.

Pure substances have characteristics different from mixtures. Constituent particles of pure substances have fixed composition. Copper, silver, gold, water and glucose are some examples of pure substances. Glucose contains carbon, hydrogen and oxygen in a fixed ratio and its particles are of same composition. Hence, like all other pure substances, glucose has a fixed composition. Also, its constituents—carbon, hydrogen and oxygen—cannot be separated by simple physical methods.

Pure substances can further be classified into **elements** and **compounds**. Particles of an **element** consist of only one type of atoms. These particles may exist as **atoms** or **molecules**. You may be familiar with atoms

and molecules from the previous classes; however, you will be studying about them in detail in Unit 2. Sodium, copper, silver, hydrogen, oxygen, etc., are some examples of elements. Their all atoms are of one type. However, the atoms of different elements are different in nature. Some elements, such as sodium or copper, contain atoms as their constituent particles, whereas, in some others, the constituent particles are molecules which are formed by two or more atoms. For example, hydrogen, nitrogen and oxygen gases consist of molecules, in which two atoms combine to give their respective molecules. This is illustrated in Fig. 1.3.

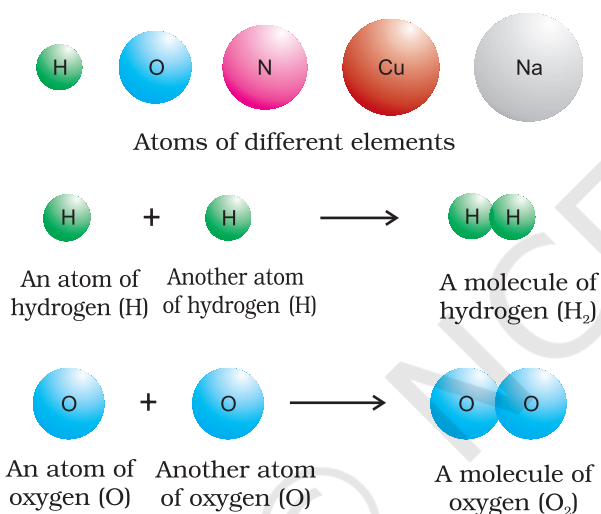

Fig. 1.3 A representation of atoms and molecules

When two or more atoms of different elements combine together in a definite ratio, the molecule of a **compound** is obtained. Moreover, the constituents of a compound cannot be separated into simpler substances by physical methods. They can be separated by chemical methods. Examples of some compounds are water, ammonia, carbon dioxide, sugar, etc. The molecules of water and carbon dioxide are represented in Fig. 1.4.

Note that a water molecule comprises two hydrogen atoms and one oxygen atom. Similarly, a molecule of carbon dioxide contains two oxygen atoms combined with one carbon atom. Thus, the atoms of different

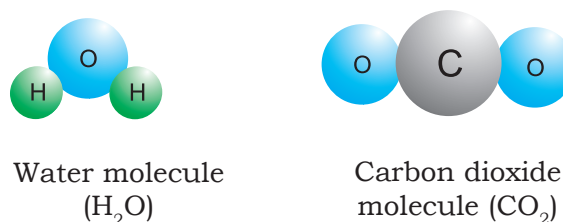

Fig. 1.4 A depiction of molecules of water and carbon dioxide

elements are present in a compound in a fixed and definite ratio and this ratio is characteristic of a particular compound. Also, the properties of a compound are different from those of its constituent elements. For example, hydrogen and oxygen are gases, whereas, the compound formed by their combination i.e., water is a liquid. It is interesting to note that hydrogen burns with a pop sound and oxygen is a supporter of combustion, but water is used as a fire extinguisher.

1.3 PROPERTIES OF MATTER AND THEIR MEASUREMENT

1.3.1 Physical and chemical properties

Every substance has unique or characteristic properties. These properties can be classified into two categories — **physical properties**, such as colour, odour, melting point, boiling point, density, etc., and **chemical properties**, like composition, combustibility, reactivity with acids and bases, etc.

Physical properties can be measured or observed without changing the identity or the composition of the substance. The measurement or observation of **chemical properties** requires a chemical change to occur. Measurement of physical properties does not require occurrence of a chemical change. The examples of chemical properties are characteristic reactions of different substances; these include acidity or basicity, combustibility, etc. Chemists describe, interpret and predict the behaviour of substances on the basis of knowledge of their physical and chemical properties, which are determined by careful measurement and experimentation. In the following section, we

will learn about the measurement of physical properties.

1.3.2 Measurement of physical properties

Quantitative measurement of properties is required for scientific investigation. Many properties of matter, such as length, area, volume, etc., are quantitative in nature. Any quantitative observation or measurement is represented by a number followed by units in which it is measured. For example, length of a room can be represented as 6 m; here, 6 is the number and m denotes metre, the unit in which the length is measured.

Earlier, two different systems of measurement, i.e., the **English System** and the **Metric System** were being used in different parts of the world. The metric system, which originated in France in late eighteenth century, was more convenient as it was based on the decimal system. Late, need of a common standard system was felt by the scientific community. Such a system was established in 1960 and is discussed in detail below.

1.3.3 The International System of Units (SI)

The International System of Units (in French *Le Systeme International d'Unités* — abbreviated as SI) was established by the 11th General Conference on Weights and Measures (CGPM from *Conference Generale des Poids et Mesures*). The CGPM is an inter-

Maintaining the National Standards of Measurement

The system of units, including unit definitions, keeps on changing with time. Whenever the accuracy of measurement of a particular unit was enhanced substantially by adopting new principles, member nations of metre treaty (signed in 1875), agreed to change the formal definition of that unit. Each modern industrialised country, including India, has a National Metrology Institute (NMI), which maintains standards of measurements. This responsibility has been given to the National Physical Laboratory (NPL), New Delhi. This laboratory establishes experiments to realise the *base units* and *derived units* of measurement and maintains National Standards of Measurement. These standards are periodically inter-compared with standards maintained at other National Metrology Institutes in the world, as well as those, established at the International Bureau of Standards in Paris.

governmental treaty organisation created by a diplomatic treaty known as Metre Convention, which was signed in Paris in 1875.

The SI system has seven base units and they are listed in Table 1.1. These units pertain to the seven fundamental scientific quantities. The other physical quantities, such as speed, volume, density, etc., can be derived from these quantities.

Table 1.1 Base Physical Quantities and their Units

Base Physical Quantity	Symbol for Quantity	Name of SI Unit	Symbol for SI Unit
Length	l	metre	m
Mass	m	kilogram	kg
Time	t	second	s
Electric current	I	ampere	A
Thermodynamic temperature	T	kelvin	K
Amount of substance	n	mole	mol
Luminous intensity	I_v	candela	cd

The definitions of the SI base units are given in Table 1.2.

The SI system allows the use of prefixes to indicate the multiples or submultiples of a unit.

These prefixes are listed in Table 1.3.

Let us now quickly go through some of the quantities which you will be often using in this book.

Table 1.2 Definitions of SI Base Units

Unit of length	metre	The <i>metre</i> , symbol m is the SI unit of length. It is defined by taking the fixed numerical value of the speed of light in vacuum c to be 299792458 when expressed in the unit ms^{-1} , where the second is defined in terms of the caesium frequency ΔV_{Cs} .
Unit of mass	kilogram	The <i>kilogram</i> , symbol kg, is the SI unit of mass. It is defined by taking the fixed numerical value of the Planck constant h to be $6.62607015 \times 10^{-34}$ when expressed in the unit Js, which is equal to $\text{kgm}^2\text{s}^{-1}$, where the metre and the second are defined in terms of c and ΔV_{Cs} .
Unit of time	second	The second symbol s, is the SI unit of time. It is defined by taking the fixed numerical value of the caesium frequency ΔV_{Cs} , the unperturbed ground-state hyperfine transition frequency of the caesium-133 atom, to be 9192631770 when expressed in the unit Hz, which is equal to s^{-1} .
Unit of electric current	ampere	The <i>ampere</i> , symbol A, is the SI unit of electric current. It is defined by taking the fixed numerical value of the elementary charge e to be $1.602176634 \times 10^{-19}$ when expressed in the unit C, which is equal to As, where the second is defined in terms of ΔV_{Cs} .
Unit of thermodynamic temperature	kelvin	The Kelvin, symbol k, is the SI unit of thermodynamic temperature. It is defined by taking the fixed numerical value of the Boltzmann constant k to be 1.380649×10^{-23} when expressed in the unit JK^{-1} , which is equal to $\text{kgm}^2\text{s}^{-2}\text{k}^{-1}$ where the kilogram, metre and second are defined in terms of h , c and ΔV_{Cs} .
Unit of amount of substance	mole	The mole, symbol mol, is the SI unit of amount of substance. One mole contains exactly $6.02214076 \times 10^{23}$ elementary entities. This number is the fixed numerical value of the Avogadro constant, N_{A} , when expressed in the unit mol^{-1} and is called the Avogadro number. The amount of substance, symbol n , of a system is a measure of the number of specified elementary entities. An elementary entity may be an atom, a molecule, an ion, an electron, any other particle or specified group of particles.
Unit of luminous intensity	Candela	The candela, symbol cd is the SI unit of luminous intensity in a given direction. It is defined by taking the fixed numerical value of the luminous efficacy of monochromatic radiation of frequency 540×10^{12} Hz, K_{cd} , to be 683 when expressed in the unit $\text{lm}\cdot\text{W}^{-1}$, which is equal to $\text{cd}\cdot\text{sr}\cdot\text{W}^{-1}$, or $\text{cd sr kg}^{-1}\text{m}^{-2}\text{s}^3$, where the kilogram, metre and second are defined in terms of h , c and ΔV_{Cs} .

Table 1.3 Prefixes used in the SI System

Multiple	Prefix	Symbol
10^{-24}	yocto	y
10^{-21}	zepto	z
10^{-18}	atto	a
10^{-15}	femto	f
10^{-12}	pico	p
10^{-9}	nano	n
10^{-6}	micro	μ
10^{-3}	milli	m
10^{-2}	centi	c
10^{-1}	deci	d
10	deca	da
10^2	hecto	h
10^3	kilo	k
10^6	mega	M
10^9	giga	G
10^{12}	tera	T
10^{15}	peta	P
10^{18}	exa	E
10^{21}	zeta	Z
10^{24}	yotta	Y

1.3.4 Mass and Weight

Mass of a substance is the amount of matter present in it, while **weight** is the force exerted by gravity on an object. The mass of a substance is constant, whereas, its weight may vary from one place to another due to change in gravity. You should be careful in using these terms.

The mass of a substance can be determined accurately in the laboratory by using an analytical balance (Fig. 1.5).

The SI unit of mass as given in Table 1.1 is kilogram. However, its fraction named as gram ($1 \text{ kg} = 1000 \text{ g}$), is used in laboratories due to the smaller amounts of chemicals used in chemical reactions.

1.3.5 Volume

Volume is the amount of space occupied by a substance. It has the units of $(\text{length})^3$. So in

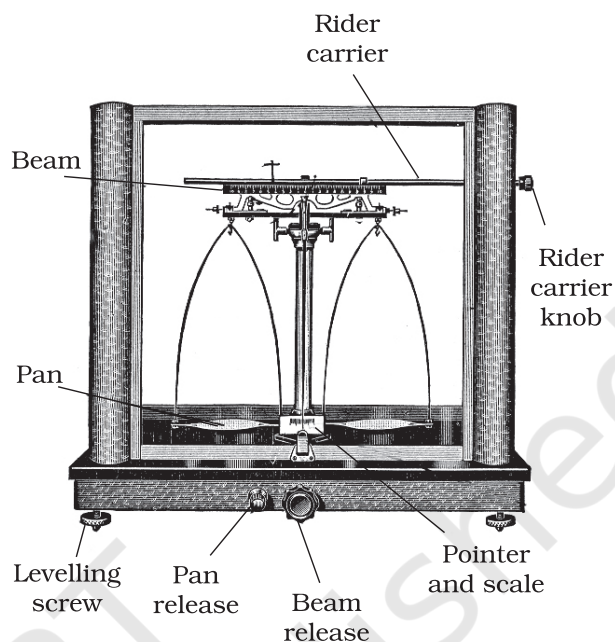
**Fig. 1.5** Analytical balance

SI system, volume has units of m^3 . But again, in chemistry laboratories, smaller volumes are used. Hence, volume is often denoted in cm^3 or dm^3 units.

A common unit, litre (L) which is not an SI unit, is used for measurement of volume of liquids.

$$1 \text{ L} = 1000 \text{ mL}, \quad 1000 \text{ cm}^3 = 1 \text{ dm}^3$$

Fig. 1.6 helps to visualise these relations.

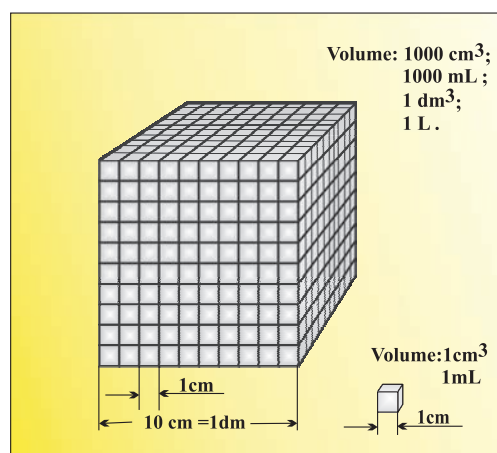
**Fig. 1.6** Different units used to express volume

In the laboratory, the volume of liquids or solutions can be measured by graduated cylinder, burette, pipette, etc. A volumetric flask is used to prepare a known volume of a solution. These measuring devices are shown in Fig. 1.7.

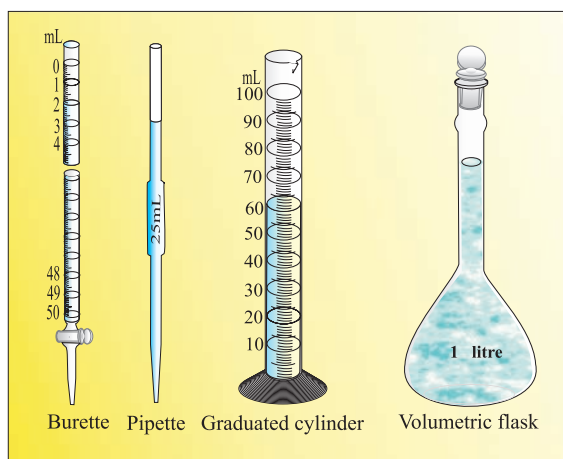

Fig. 1.7 Some volume measuring devices

1.3.6 Density

The two properties — mass and volume discussed above are related as follows:

$$\text{Density} = \frac{\text{Mass}}{\text{Volume}}$$

Density of a substance is its amount of mass per unit volume. So, SI units of density can be obtained as follows:

$$\begin{aligned} \text{SI unit of density} &= \frac{\text{SI unit of mass}}{\text{SI unit of volume}} \\ &= \frac{\text{kg}}{\text{m}^3} \text{ or } \text{kg m}^{-3} \end{aligned}$$

This unit is quite large and a chemist often expresses density in g cm^{-3} , where mass is expressed in gram and volume is expressed in cm^3 . Density of a substance tells us about how closely its particles are packed. If density is more, it means particles are more closely packed.

1.3.7 Temperature

There are three common scales to measure temperature — $^{\circ}\text{C}$ (degree celsius), $^{\circ}\text{F}$ (degree

fahrenheit) and K (kelvin). Here, K is the SI unit. The thermometers based on these scales are shown in Fig. 1.8. Generally, the thermometer with celsius scale are calibrated from 0° to 100° , where these two temperatures are the freezing point and the boiling point of water, respectively. The fahrenheit scale is represented between 32° to 212° .

The temperatures on two scales are related to each other by the following relationship:

$$^{\circ}\text{F} = \frac{9}{5}(^{\circ}\text{C}) + 32$$

The kelvin scale is related to celsius scale as follows:

$$\text{K} = ^{\circ}\text{C} + 273.15$$

It is interesting to note that temperature below 0°C (i.e., negative values) are possible in Celsius scale but in Kelvin scale, negative temperature is not possible.

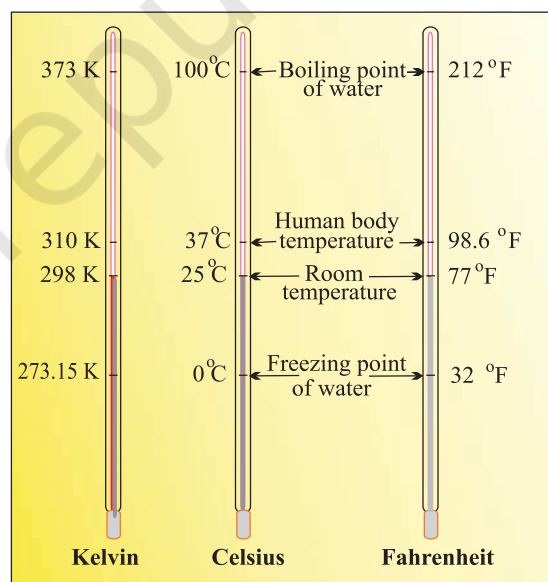

Fig. 1.8 Thermometers using different temperature scales

1.4 UNCERTAINTY IN MEASUREMENT

Many a time in the study of chemistry, one has to deal with experimental data as well as theoretical calculations. There are meaningful ways to handle the numbers conveniently and

Multiplication and Division

These two operations follow the same rules which are there for exponential numbers, i.e.

$$\begin{aligned}(5.6 \times 10^5) \times (6.9 \times 10^8) &= (5.6 \times 6.9)(10^{5+8}) \\ &= (5.6 \times 6.9) \times 10^{13} \\ &= 38.64 \times 10^{13} \\ &= 3.864 \times 10^{14}\end{aligned}$$

$$\begin{aligned}(9.8 \times 10^{-2}) \times (2.5 \times 10^{-6}) &= (9.8 \times 2.5)(10^{-2+(-6)}) \\ &= (9.8 \times 2.5)(10^{-2-6}) \\ &= 24.50 \times 10^{-8} \\ &= 2.450 \times 10^{-7}\end{aligned}$$

$$\begin{aligned}\frac{2.7 \times 10^{-3}}{5.5 \times 10^4} &= (2.7 \div 5.5)(10^{-3-4}) = 0.4909 \times 10^{-7} \\ &= 4.909 \times 10^{-8}\end{aligned}$$

Addition and Subtraction

For these two operations, first the numbers are written in such a way that they have the same exponent. After that, the coefficients (digit terms) are added or subtracted as the case may be.

Thus, for adding 6.65×10^4 and 8.95×10^3 , exponent is made same for both the numbers. Thus, we get $(6.65 \times 10^4) + (0.895 \times 10^4)$

Then, these numbers can be added as follows $(6.65 + 0.895) \times 10^4 = 7.545 \times 10^4$

Similarly, the subtraction of two numbers can be done as shown below:

$$\begin{aligned}(2.5 \times 10^{-2}) - (4.8 \times 10^{-3}) \\ &= (2.5 \times 10^{-2}) - (0.48 \times 10^{-2}) \\ &= (2.5 - 0.48) \times 10^{-2} = 2.02 \times 10^{-2}\end{aligned}$$

1.4.2 Significant Figures

Every experimental measurement has some amount of uncertainty associated with it because of limitation of measuring instrument and the skill of the person making the measurement. For example, mass of an object is obtained using a platform balance and it comes out to be 9.4g. On measuring the mass of this object on an analytical balance, the mass obtained is 9.4213g. The

mass obtained by an analytical balance is slightly higher than the mass obtained by using a platform balance. Therefore, digit 4 placed after decimal in the measurement by platform balance is uncertain.

The uncertainty in the experimental or the calculated values is indicated by mentioning the number of significant figures. **Significant figures** are meaningful digits which are known with certainty plus one which is estimated or uncertain. The uncertainty is indicated by writing the certain digits and the last uncertain digit. Thus, if we write a result as 11.2 mL, we say the 11 is certain and 2 is uncertain and the uncertainty would be ± 1 in the last digit. Unless otherwise stated, an uncertainty of ± 1 in the last digit is always understood.

There are certain rules for determining the number of significant figures. These are stated below:

- (1) All non-zero digits are significant. For example in 285 cm, there are three significant figures and in 0.25 mL, there are two significant figures.
- (2) Zeros preceding to first non-zero digit are not significant. Such zero indicates the position of decimal point. Thus, 0.03 has one significant figure and 0.0052 has two significant figures.
- (3) Zeros between two non-zero digits are significant. Thus, 2.005 has four significant figures.
- (4) Zeros at the end or right of a number are significant, provided they are on the right side of the decimal point. For example, 0.200 g has three significant figures. But, if otherwise, the terminal zeros are not significant if there is no decimal point. For example, 100 has only one significant figure, but 100 has three significant figures and 100.0 has four significant figures. Such numbers are better represented in scientific notation. We can express the number 100 as 1×10^2 for one significant figure, 1.0×10^2 for two significant figures and 1.00×10^2 for three significant figures.

- (5) Counting the numbers of object, for example, 2 balls or 20 eggs, have infinite significant figures as these are exact numbers and can be represented by writing infinite number of zeros after placing a decimal i.e., $2 = 2.000000$ or $20 = 20.000000$.

In numbers written in scientific notation, all digits are significant e.g., 4.01×10^2 has three significant figures, and 8.256×10^{-3} has four significant figures.

However, one would always like the results to be precise and accurate. Precision and accuracy are often referred to while we talk about the measurement.

Precision refers to the closeness of various measurements for the same quantity. However, **accuracy** is the agreement of a particular value to the true value of the result. For example, if the true value for a result is 2.00 g and student 'A' takes two measurements and reports the results as 1.95 g and 1.93 g. These values are precise as they are close to each other but are not accurate. Another student 'B' repeats the experiment and obtains 1.94 g and 2.05 g as the results for two measurements. These observations are neither precise nor accurate. When the third student 'C' repeats these measurements and reports 2.01 g and 1.99 g as the result, these values are both precise and accurate. This can be more clearly understood from the data given in Table 1.4.

Table 1.4 Data to Illustrate Precision and Accuracy

Measurements/g			
	1	2	Average (g)
Student A	1.95	1.93	1.940
Student B	1.94	2.05	1.995
Student C	2.01	1.99	2.000

Addition and Subtraction of Significant Figures

The result cannot have more digits to the right of the decimal point than either of the original numbers.

$$\begin{array}{r} 12.11 \\ 18.0 \\ \underline{1.012} \\ 31.122 \end{array}$$

Here, 18.0 has only one digit after the decimal point and the result should be reported only up to one digit after the decimal point, which is 31.1.

Multiplication and Division of Significant Figures

In these operations, the result must be reported with no more significant figures as in the measurement with the few significant figures.

$$2.5 \times 1.25 = 3.125$$

Since 2.5 has two significant figures, the result should not have more than two significant figures, thus, it is 3.1.

While limiting the result to the required number of significant figures as done in the above mathematical operation, one has to keep in mind the following points for rounding off the numbers

1. If the rightmost digit to be removed is more than 5, the preceding number is increased by one. For example, 1.386. If we have to remove 6, we have to round it to 1.39.
2. If the rightmost digit to be removed is less than 5, the preceding number is not changed. For example, 4.334 if 4 is to be removed, then the result is rounded upto 4.33.
3. If the rightmost digit to be removed is 5, then the preceding number is not changed if it is an even number but it is increased by one if it is an odd number. For example, if 6.35 is to be rounded by removing 5, we have to increase 3 to 4 giving 6.4 as the result. However, if 6.25 is to be rounded off it is rounded off to 6.2.

1.4.3 Dimensional Analysis

Often while calculating, there is a need to convert units from one system to the other. The method used to accomplish this is called **factor label method** or **unit factor method** or **dimensional analysis**. This is illustrated below.

Example

A piece of metal is 3 inch (represented by in) long. What is its length in cm?

Solution

We know that 1 in = 2.54 cm

From this equivalence, we can write

$$\frac{1 \text{ in}}{2.54 \text{ cm}} = 1 = \frac{2.54 \text{ cm}}{1 \text{ in}}$$

Thus, $\frac{1 \text{ in}}{2.54 \text{ cm}}$ equals 1 and $\frac{2.54 \text{ cm}}{1 \text{ in}}$

also equals 1. Both of these are called **unit factors**. If some number is multiplied by these unit factors (i.e., 1), it will not be affected otherwise.

Say, the 3 in given above is multiplied by the unit factor. So,

$$3 \text{ in} = 3 \text{ in} \times \frac{2.54 \text{ cm}}{1 \text{ in}} = 3 \times 2.54 \text{ cm} = 7.62 \text{ cm}$$

Now, the unit factor by which multiplication is to be done is that unit factor ($\frac{2.54 \text{ cm}}{1 \text{ in}}$ in

the above case) which gives the desired units i.e., the numerator should have that part which is required in the desired result.

It should also be noted in the above example that units can be handled just like other numerical part. It can be cancelled, divided, multiplied, squared, etc. Let us study one more example.

Example

A jug contains 2L of milk. Calculate the volume of the milk in m^3 .

Solution

Since 1 L = 1000 cm^3
and 1m = 100 cm, which gives

$$\frac{1 \text{ m}}{100 \text{ cm}} = 1 = \frac{100 \text{ cm}}{1 \text{ m}}$$

To get m^3 from the above unit factors, the first unit factor is taken and it is cubed.

$$\left(\frac{1 \text{ m}}{100 \text{ cm}}\right)^3 \Rightarrow \frac{1 \text{ m}^3}{10^6 \text{ cm}^3} = (1)^3 = 1$$

Now 2 L = 2 × 1000 cm^3

The above is multiplied by the unit factor

$$2 \times 1000 \text{ cm}^3 \times \frac{1 \text{ m}^3}{10^6 \text{ cm}^3} = \frac{2 \text{ m}^3}{10^3} = 2 \times 10^{-3} \text{ m}^3$$

Example

How many seconds are there in 2 days?

Solution

Here, we know 1 day = 24 hours (h)

$$\text{or } \frac{1 \text{ day}}{24 \text{ h}} = 1 = \frac{24 \text{ h}}{1 \text{ day}}$$

then, 1h = 60 min

$$\text{or } \frac{1 \text{ h}}{60 \text{ min}} = 1 = \frac{60 \text{ min}}{1 \text{ h}}$$

so, for converting 2 days to seconds,

i.e., 2 days ----- = ---- seconds

The unit factors can be multiplied in series in one step only as follows:

$$2 \text{ day} \times \frac{24 \text{ h}}{1 \text{ day}} \times \frac{60 \text{ min}}{1 \text{ h}} \times \frac{60 \text{ s}}{1 \text{ min}}$$

$$= 2 \times 24 \times 60 \times 60 \text{ s}$$

$$= 172800 \text{ s}$$

1.5 LAWS OF CHEMICAL COMBINATIONS

The combination of elements to form compounds is governed by the following five basic laws.



Antoine Lavoisier
(1743–1794)

1.5.1 Law of Conservation of Mass

This law was put forth by Antoine Lavoisier in 1789. He performed careful experimental studies for combustion reactions and reached to the conclusion that in all physical and chemical changes, there is no net change in mass during the process. Hence, he reached to the conclusion that matter can neither be created nor destroyed. This is called 'Law of Conservation of Mass'. This law formed the basis for several later developments in chemistry. Infact, this was the result of exact measurement of masses of reactants and products, and carefully planned experiments performed by Lavoisier.

1.5.2 Law of Definite Proportions

This law was given by, a French chemist, Joseph Proust. He stated that *a given compound always contains exactly the same proportion of elements by weight.*



Joseph Proust
(1754–1826)

Proust worked with two samples of cupric carbonate — one of which was of natural origin and the other was synthetic. He found that the composition of elements present in it was same for both the samples as shown below:

	% of copper	% of carbon	% of oxygen
Natural Sample	51.35	9.74	38.91
Synthetic Sample	51.35	9.74	38.91

Thus, he concluded that irrespective of the source, a given compound always contains same elements combined together in the same proportion by mass. The validity of this law has been confirmed by various experiments. It is sometimes also referred to as **Law of Definite Composition.**

1.5.3 Law of Multiple Proportions

This law was proposed by Dalton in 1803. According to this law, *if two elements can combine to form more than one compound, the masses of one element that combine with a fixed mass of the other element, are in the ratio of small whole numbers.*

For example, hydrogen combines with oxygen to form two compounds, namely, water and hydrogen peroxide.

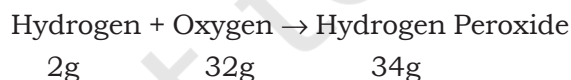
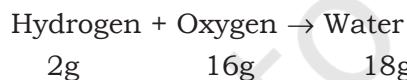

Here, the masses of oxygen (i.e., 16 g and 32 g), which combine with a fixed mass of hydrogen (2g) bear a simple ratio, i.e., 16:32 or 1: 2.

1.5.4 Gay Lussac's Law of Gaseous Volumes

This law was given by Gay Lussac in 1808. He observed that *when gases combine or*

are produced in a chemical reaction they do so in a simple ratio by volume, provided all gases are at the same temperature and pressure.



Joseph Louis
Gay Lussac

Thus, 100 mL of hydrogen combine with 50 mL of oxygen to give 100 mL of water vapour.

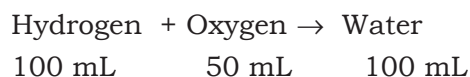

Thus, the volumes of hydrogen and oxygen which combine (i.e., 100 mL and 50 mL) bear a simple ratio of 2:1.

Gay Lussac's discovery of integer ratio in volume relationship is actually the law of definite proportions by volume. The law of definite proportions, stated earlier, was with respect to mass. The Gay Lussac's law was explained properly by the work of Avogadro in 1811.

1.5.5 Avogadro's Law

In 1811, Avogadro proposed that *equal volumes of all gases at the same temperature and pressure should contain equal number of molecules.* Avogadro made a distinction between **atoms** and **molecules** which is quite understandable in present times. If we consider again the reaction of hydrogen and oxygen to produce water, we see that two volumes of hydrogen combine with one volume of oxygen to give two volumes of water without leaving any unreacted oxygen.

Note that in the Fig. 1.9 (Page 16) each box contains equal number of molecules. In fact, Avogadro could explain the above result by considering the molecules to be **polyatomic**. If hydrogen and oxygen were considered as **diatomic** as recognised now, then the above results are easily understandable. However, Dalton and others believed at that time that atoms of the same kind



Lorenzo Romano
Amedeo Carlo
Avogadro di
Quaregna ed i
Carreto
(1776–1856)

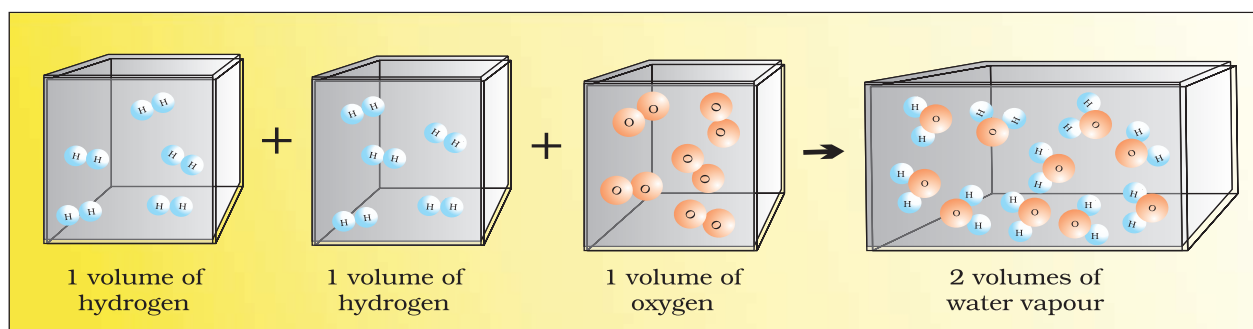

Fig. 1.9 Two volumes of hydrogen react with one volume of oxygen to give two volumes of water vapour

cannot combine and molecules of oxygen or hydrogen containing two atoms did not exist. Avogadro's proposal was published in the French *Journal de Physique*. In spite of being correct, it did not gain much support.

After about 50 years, in 1860, the first international conference on chemistry was held in Karlsruhe, Germany, to resolve various ideas. At the meeting, Stanislao Cannizzaro presented a sketch of a course of chemical philosophy, which emphasised on the importance of Avogadro's work.

1.6 DALTON'S ATOMIC THEORY

Although the origin of the idea that matter is composed of small indivisible particles called 'a-tomio' (meaning, *indivisible*), dates back to the time of Democritus, a Greek Philosopher (460–370 BC), it again started emerging as a result of several experimental studies which led to the laws mentioned above.



John Dalton
(1776–1884)

In 1808, Dalton published 'A New System of Chemical Philosophy', in which he proposed the following :

1. Matter consists of indivisible atoms.
2. All atoms of a given element have identical properties, including identical mass. Atoms of different elements differ in mass.
3. Compounds are formed when atoms of different elements combine in a fixed ratio.
4. Chemical reactions involve reorganisation of atoms. These are neither created nor destroyed in a chemical reaction.

Dalton's theory could explain the laws of chemical combination. However, it could not explain the laws of gaseous volumes. It could not provide the reason for combining of atoms, which was answered later by other scientists.

1.7 ATOMIC AND MOLECULAR MASSES

After having some idea about the terms atoms and molecules, it is appropriate here to understand what do we mean by atomic and molecular masses.

1.7.1 Atomic Mass

The atomic mass or the mass of an atom is actually very-very small because atoms are extremely small. Today, we have sophisticated techniques e.g., mass spectrometry for determining the atomic masses fairly accurately. But in the nineteenth century, scientists could determine the mass of one atom **relative** to another by experimental means, as has been mentioned earlier. Hydrogen, being the lightest atom was arbitrarily assigned a mass of 1 (without any units) and other elements were assigned masses relative to it. However, the present system of atomic masses is based on carbon-12 as the standard and has been agreed upon in 1961. Here, Carbon-12 is one of the **isotopes** of carbon and can be represented as ^{12}C . In this system, ^{12}C is assigned a mass of exactly 12 atomic mass unit (**amu**) and masses of all other atoms are given relative to this standard. One **atomic mass unit** is defined as a mass exactly equal to one-twelfth of the mass of one carbon – 12 atom.

And $1 \text{ amu} = 1.66056 \times 10^{-24} \text{ g}$

Mass of an atom of hydrogen
 $= 1.6736 \times 10^{-24} \text{ g}$

Thus, in terms of amu, the mass
of hydrogen atom $= \frac{1.6736 \times 10^{-24} \text{ g}}{1.66056 \times 10^{-24} \text{ g}}$
 $= 1.0078 \text{ amu}$
 $= 1.0080 \text{ amu}$

Similarly, the mass of oxygen - 16 (^{16}O) atom would be 15.995 amu.

At present, 'amu' has been replaced by 'u', which is known as **unified mass**.

When we use atomic masses of elements in calculations, we actually use *average atomic masses* of elements, which are explained below.

1.7.2 Average Atomic Mass

Many naturally occurring elements exist as more than one isotope. When we take into account the existence of these isotopes and their relative abundance (per cent occurrence), the average atomic mass of that element can be computed. For example, carbon has the following three isotopes with relative abundances and masses as shown against each of them.

Isotope	Relative Abundance (%)	Atomic Mass (amu)
^{12}C	98.892	12
^{13}C	1.108	13.00335
^{14}C	2×10^{-10}	14.00317

From the above data, the average atomic mass of carbon will come out to be:
 $(0.98892) (12 \text{ u}) + (0.01108) (13.00335 \text{ u}) + (2 \times 10^{-12}) (14.00317 \text{ u}) = 12.011 \text{ u}$

Similarly, average atomic masses for other elements can be calculated. In the periodic table of elements, the atomic masses mentioned for different elements actually represent their average atomic masses.

1.7.3 Molecular Mass

Molecular mass is the sum of atomic masses of the elements present in a molecule. It is obtained by multiplying the atomic mass of each element by the number of its atoms and adding them together. For example, molecular mass of methane, which contains one carbon atom and four hydrogen atoms, can be obtained as follows:

Molecular mass of methane,
 $(\text{CH}_4) = (12.011 \text{ u}) + 4 (1.008 \text{ u})$
 $= 16.043 \text{ u}$

Similarly, molecular mass of water (H_2O)
 $= 2 \times \text{atomic mass of hydrogen} + 1 \times \text{atomic mass of oxygen}$
 $= 2 (1.008 \text{ u}) + 16.00 \text{ u}$
 $= 18.02 \text{ u}$

1.7.4 Formula Mass

Some substances, such as sodium chloride, do not contain discrete molecules as their constituent units. In such compounds, positive (sodium ion) and negative (chloride ion) entities are arranged in a three-dimensional structure, as shown in Fig. 1.10.

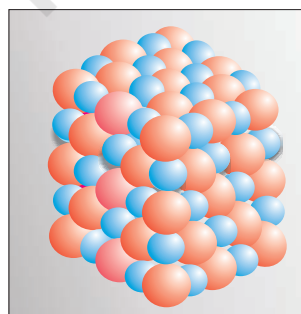

Fig. 1.10 Packing of Na^+ and Cl^- ions in sodium chloride

It may be noted that in sodium chloride, one Na^+ ion is surrounded by six Cl^- ion and *vice-versa*.

The formula, such as NaCl , is used to calculate the **formula mass** instead of molecular mass as in the solid state sodium chloride does not exist as a single entity.

Thus, the formula mass of sodium chloride is atomic mass of sodium + atomic mass of chlorine
 $= 23.0 \text{ u} + 35.5 \text{ u} = 58.5 \text{ u}$

Problem 1.1

Calculate the molecular mass of glucose ($\text{C}_6\text{H}_{12}\text{O}_6$) molecule.

Solution

Molecular mass of glucose ($\text{C}_6\text{H}_{12}\text{O}_6$)
 $= 6 (12.011 \text{ u}) + 12 (1.008 \text{ u}) +$
 $\qquad\qquad\qquad 6 (16.00 \text{ u})$
 $= (72.066 \text{ u}) + (12.096 \text{ u}) +$
 $\qquad\qquad\qquad (96.00 \text{ u})$
 $= 180.162 \text{ u}$

1.8 MOLE CONCEPT AND MOLAR MASSES

Atoms and molecules are extremely small in size and their numbers in even a small amount of any substance is really very large. To handle such large numbers, a unit of convenient magnitude is required.

Just as we denote one dozen for 12 items, score for 20 items, gross for 144 items, we use the idea of mole to count entities at the microscopic level (i.e., atoms, molecules, particles, electrons, ions, etc).

In SI system, **mole** (symbol, mol) was introduced as seventh base quantity for the amount of a substance.

The mole, symbol mol, is the SI unit of amount of substance. One mole contains exactly $6.02214076 \times 10^{23}$ elementary entities. This number is the fixed numerical value of the Avogadro constant, N_A , when expressed in the unit mol^{-1} and is called the Avogadro number. The amount of substance, symbol n , of a system is a measure of the number of specified elementary entities. An elementary entity may be an atom, a molecule, an ion, an electron, any other particle or specified group of particles. It may be emphasised that the mole of a substance always contains the same number of entities, no matter what the substance may be. In order to determine this number precisely, the mass of a carbon-12 atom was determined by a mass spectrometer and found to be equal to 1.992648×10^{-23} g. Knowing that one mole of carbon weighs 12 g, the number of atoms in it is equal to:

$$\frac{12 \text{ g/mol } ^{12}\text{C}}{1.992648 \times 10^{-23} \text{ g/}^{12}\text{C atom}}$$

$$= 6.0221367 \times 10^{23} \text{ atoms/mol}$$

This number of entities in 1 mol is so important that it is given a separate name and symbol. It is known as '**Avogadro constant**', or Avogadro number denoted by N_A in honour of Amedeo Avogadro. To appreciate the largeness of this number, let us write it with all zeroes without using any powers of ten.

60221367000000000000000000

Hence, so many entities (atoms, molecules or any other particle) constitute one mole of a particular substance.

We can, therefore, say that 1 mol of hydrogen atoms = 6.022×10^{23} atoms

1 mol of water molecules = 6.022×10^{23} water molecules

1 mol of sodium chloride = 6.022×10^{23} formula units of sodium chloride

Having defined the mole, it is easier to know the mass of one mole of a substance or the constituent entities. **The mass of one mole of a substance in grams is called its molar mass.** The molar mass in grams is numerically equal to atomic/molecular/formula mass in u.

Molar mass of water = 18.02 g mol^{-1}

Molar mass of sodium chloride = 58.5 g mol^{-1}

1.9 PERCENTAGE COMPOSITION

So far, we were dealing with the number of entities present in a given sample. But many a time, information regarding the percentage of a particular element present in a compound is required. Suppose, an unknown or new compound is given to you, the first question



Fig. 1.11 One mole of various substances

you would ask is: what is its formula or what are its constituents and in what ratio are they present in the given compound? For known compounds also, such information provides a check whether the given sample contains the same percentage of elements as present in a pure sample. In other words, one can check the purity of a given sample by analysing this data.

Let us understand it by taking the example of water (H₂O). Since water contains hydrogen and oxygen, the percentage composition of both these elements can be calculated as follows:

Mass % of an element =

$$\frac{\text{mass of that element in the compound} \times 100}{\text{molar mass of the compound}}$$

Molar mass of water = 18.02 g

$$\begin{aligned} \text{Mass \% of hydrogen} &= \frac{2 \times 1.008}{18.02} \times 100 \\ &= 11.18 \end{aligned}$$

$$\begin{aligned} \text{Mass \% of oxygen} &= \frac{16.00}{18.02} \times 100 \\ &= 88.79 \end{aligned}$$

Let us take one more example. What is the percentage of carbon, hydrogen and oxygen in ethanol?

Molecular formula of ethanol is: C₂H₅OH

Molar mass of ethanol is:

$$(2 \times 12.01 + 6 \times 1.008 + 16.00) \text{ g} = 46.068 \text{ g}$$

Mass per cent of carbon

$$= \frac{24.02 \text{ g}}{46.068 \text{ g}} \times 100 = 52.14\%$$

Mass per cent of hydrogen

$$= \frac{6.048 \text{ g}}{46.068 \text{ g}} \times 100 = 13.13\%$$

Mass per cent of oxygen

$$= \frac{16.00 \text{ g}}{46.068 \text{ g}} \times 100 = 34.73\%$$

After understanding the calculation of per cent of mass, let us now see what information can be obtained from the per cent composition data.

1.9.1 Empirical Formula for Molecular Formula

An **empirical formula** represents the simplest whole number ratio of various atoms present in a compound, whereas, the **molecular formula** shows the exact number of different types of atoms present in a molecule of a compound.

If the mass per cent of various elements present in a compound is known, its empirical formula can be determined. Molecular formula can further be obtained if the molar mass is known. The following example illustrates this sequence.

Problem 1.2

A compound contains 4.07% hydrogen, 24.27% carbon and 71.65% chlorine. Its molar mass is 98.96 g. What are its empirical and molecular formulas?

Solution

Step 1. Conversion of mass per cent to grams

Since we are having mass per cent, it is convenient to use 100 g of the compound as the starting material. Thus, in the 100 g sample of the above compound, 4.07g hydrogen, 24.27g carbon and 71.65g chlorine are present.

Step 2. Convert into number moles of each element

Divide the masses obtained above by respective atomic masses of various elements. This gives the number of moles of constituent elements in the compound

$$\text{Moles of hydrogen} = \frac{4.07 \text{ g}}{1.008 \text{ g}} = 4.04$$

$$\text{Moles of carbon} = \frac{24.27 \text{ g}}{12.01 \text{ g}} = 2.021$$

$$\text{Moles of chlorine} = \frac{71.65 \text{ g}}{35.453 \text{ g}} = 2.021$$

Step 3. Divide each of the mole values obtained above by the smallest number amongst them

Since 2.021 is smallest value, division by it gives a ratio of 2:1:1 for H:C:Cl.

In case the ratios are not whole numbers, then they may be converted into whole number by multiplying by the suitable coefficient.

Step 4. Write down the empirical formula by mentioning the numbers after writing the symbols of respective elements

CH_2Cl is, thus, the empirical formula of the above compound.

Step 5. Writing molecular formula

(a) Determine empirical formula mass by adding the atomic masses of various atoms present in the empirical formula. For CH_2Cl , empirical formula mass is $12.01 + (2 \times 1.008) + 35.453 = 49.48 \text{ g}$

(b) Divide Molar mass by empirical formula mass

$$\frac{\text{Molar mass}}{\text{Empirical formula mass}} = \frac{98.96 \text{ g}}{49.48 \text{ g}} = 2 = (n)$$

(c) Multiply empirical formula by n obtained above to get the molecular formula

Empirical formula = CH_2Cl , $n = 2$. Hence molecular formula is $\text{C}_2\text{H}_4\text{Cl}_2$.

1.10 STOICHIOMETRY AND STOICHIOMETRIC CALCULATIONS

The word 'stoichiometry' is derived from two Greek words — *stoicheion* (meaning, *element*) and *metron* (meaning, *measure*). Stoichiometry, thus, deals with the calculation of masses (sometimes volumes also) of the reactants and the products involved in a chemical reaction. Before understanding how to calculate the amounts of reactants required or the products produced in a chemical reaction, let us study what information is available from the **balanced** chemical

equation of a given reaction. Let us consider the combustion of methane. A balanced equation for this reaction is as given below:

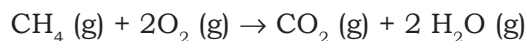

Here, methane and dioxygen are called *reactants* and carbon dioxide and water are called *products*. Note that all the reactants and the products are gases in the above reaction and this has been indicated by letter (g) in the brackets next to its formula. Similarly, in case of solids and liquids, (s) and (l) are written respectively.

The coefficients 2 for O_2 and H_2O are called stoichiometric coefficients. Similarly the coefficient for CH_4 and CO_2 is one in each case. They represent the number of molecules (and moles as well) taking part in the reaction or formed in the reaction.

Thus, according to the above chemical reaction,

- One **mole** of $\text{CH}_4(\text{g})$ reacts with two **moles** of $\text{O}_2(\text{g})$ to give one **mole** of $\text{CO}_2(\text{g})$ and two **moles** of $\text{H}_2\text{O}(\text{g})$
- One **molecule** of $\text{CH}_4(\text{g})$ reacts with 2 **molecules** of $\text{O}_2(\text{g})$ to give one **molecule** of $\text{CO}_2(\text{g})$ and 2 molecules of $\text{H}_2\text{O}(\text{g})$
- 22.7 L of $\text{CH}_4(\text{g})$ reacts with 45.4 L of $\text{O}_2(\text{g})$ to give 22.7 L of $\text{CO}_2(\text{g})$ and 45.4 L of $\text{H}_2\text{O}(\text{g})$
- 16 g of $\text{CH}_4(\text{g})$ reacts with $2 \times 32 \text{ g}$ of $\text{O}_2(\text{g})$ to give 44 g of $\text{CO}_2(\text{g})$ and $2 \times 18 \text{ g}$ of $\text{H}_2\text{O}(\text{g})$.

From these relationships, the given data can be interconverted as follows:

mass

mass \rightleftharpoons moles \rightleftharpoons no. of molecules

$$\frac{\text{Mass}}{\text{Volume}} = \text{Density}$$

1.10.1 Limiting Reagent

Many a time, reactions are carried out with the amounts of reactants that are different than the amounts as required by a balanced chemical reaction. In such situations, one reactant is in more amount than the amount required by balanced chemical reaction. The

reactant which is present in the least amount gets consumed after sometime and after that further reaction does not take place whatever be the amount of the other reactant. Hence, the reactant, which gets consumed first, limits the amount of product formed and is, therefore, called the **limiting reagent**.

In performing stoichiometric calculations, this aspect is also to be kept in mind.

1.10.2 Reactions in Solutions

A majority of reactions in the laboratories are carried out in solutions. Therefore, it is

important to understand as how the amount of substance is expressed when it is present in the solution. The concentration of a solution or the amount of substance present in its given volume can be expressed in any of the following ways.

1. Mass per cent or weight per cent (w/w %)
2. Mole fraction
3. Molarity
4. Molality

Let us now study each one of them in detail.

Balancing a chemical equation

According to the law of conservation of mass, a balanced chemical equation has the *same number of atoms of each element on both sides* of the equation. Many chemical equations can be balanced by *trial and error*. Let us take the reactions of a few metals and non-metals with oxygen to give oxides

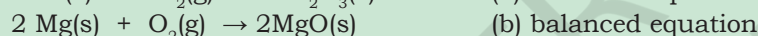
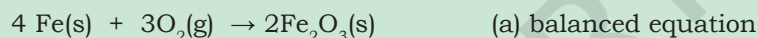

Equations (a) and (b) are balanced, since there are same number of metal and oxygen atoms on each side of the equations. However equation (c) is not balanced. In this equation, phosphorus atoms are balanced but not the oxygen atoms. To balance it, we must place the coefficient 5 on the left of oxygen on the left side of the equation to balance the oxygen atoms appearing on the right side of the equation.



Now, let us take combustion of propane, C_3H_8 . This equation can be balanced in steps.

Step 1 Write down the correct formulas of reactants and products. Here, propane and oxygen are reactants, and carbon dioxide and water are products.

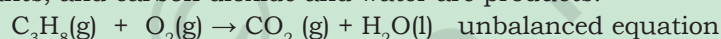

Step 2 *Balance the number of C atoms:* Since 3 carbon atoms are in the reactant, therefore, three CO_2 molecules are required on the right side.

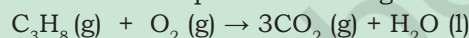

Step 3 *Balance the number of H atoms:* on the left there are 8 hydrogen atoms in the reactants however, each molecule of water has two hydrogen atoms, so four molecules of water will be required for eight hydrogen atoms on the right side.

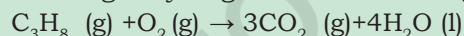

Step 4 *Balance the number of O atoms:* There are 10 oxygen atoms on the right side ($3 \times 2 = 6$ in CO_2 and $4 \times 1 = 4$ in water). Therefore, five O_2 molecules are needed to supply the required 10 CO_2 and $4 \times 1 = 4$ in water). Therefore, five O_2 molecules are needed to supply the required 10 oxygen atoms.

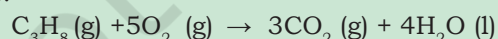

Step 5 *Verify that the number of atoms of each element is balanced in the final equation.* The equation shows three carbon atoms, eight hydrogen atoms, and 10 oxygen atoms on each side.

All equations that have correct formulas for all reactants and products can be balanced. Always remember that subscripts in formulas of reactants and products cannot be changed to balance an equation.

Problem 1.3

Calculate the amount of water (g) produced by the combustion of 16 g of methane.

Solution

The balanced equation for the combustion of methane is :

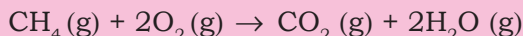

(i) 16 g of CH_4 corresponds to one mole.

(ii) From the above equation, 1 mol of $\text{CH}_4(\text{g})$ gives 2 mol of $\text{H}_2\text{O}(\text{g})$.

$$2 \text{ mol of water } (\text{H}_2\text{O}) = 2 \times (2+16) \\ = 2 \times 18 = 36 \text{ g}$$

$$1 \text{ mol H}_2\text{O} = 18 \text{ g H}_2\text{O} \Rightarrow \frac{18 \text{ g H}_2\text{O}}{1 \text{ mol H}_2\text{O}} = 1$$

$$\text{Hence, } 2 \text{ mol H}_2\text{O} \times \frac{18 \text{ g H}_2\text{O}}{1 \text{ mol H}_2\text{O}} \\ = 2 \times 18 \text{ g H}_2\text{O} = 36 \text{ g H}_2\text{O}$$

Problem 1.4

How many moles of methane are required to produce 22 g $\text{CO}_2(\text{g})$ after combustion?

Solution

According to the chemical equation,



44 g $\text{CO}_2(\text{g})$ is obtained from 16 g $\text{CH}_4(\text{g})$.

[∴ 1 mol $\text{CO}_2(\text{g})$ is obtained from 1 mol of $\text{CH}_4(\text{g})$]

Number of moles of $\text{CO}_2(\text{g})$

$$= 22 \text{ g CO}_2(\text{g}) \times \frac{1 \text{ mol CO}_2(\text{g})}{44 \text{ g CO}_2(\text{g})}$$

$$= 0.5 \text{ mol CO}_2(\text{g})$$

Hence, 0.5 mol $\text{CO}_2(\text{g})$ would be obtained from 0.5 mol $\text{CH}_4(\text{g})$ or 0.5 mol of $\text{CH}_4(\text{g})$ would be required to produce 22 g $\text{CO}_2(\text{g})$.

Problem 1.5

50.0 kg of $\text{N}_2(\text{g})$ and 10.0 kg of $\text{H}_2(\text{g})$ are mixed to produce $\text{NH}_3(\text{g})$. Calculate the amount of $\text{NH}_3(\text{g})$ formed. Identify

the limiting reagent in the production of NH_3 in this situation.

Solution

A balanced equation for the above reaction is written as follows :

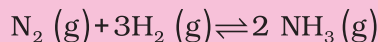

Calculation of moles :

Number of moles of N_2

$$= 50.0 \text{ kg N}_2 \times \frac{1000 \text{ g N}_2}{1 \text{ kg N}_2} \times \frac{1 \text{ mol N}_2}{28.0 \text{ g N}_2}$$

$$= 17.86 \times 10^2 \text{ mol}$$

Number of moles of H_2

$$= 10.00 \text{ kg H}_2 \times \frac{1000 \text{ g H}_2}{1 \text{ kg H}_2} \times \frac{1 \text{ mol H}_2}{2.016 \text{ g H}_2}$$

$$= 4.96 \times 10^3 \text{ mol}$$

According to the above equation, 1 mol $\text{N}_2(\text{g})$ requires 3 mol $\text{H}_2(\text{g})$, for the reaction. Hence, for 17.86×10^2 mol of N_2 , the moles of $\text{H}_2(\text{g})$ required would be

$$17.86 \times 10^2 \text{ mol N}_2 \times \frac{3 \text{ mol H}_2(\text{g})}{1 \text{ mol N}_2(\text{g})}$$

$$= 5.36 \times 10^3 \text{ mol H}_2$$

But we have only 4.96×10^3 mol H_2 . Hence, dihydrogen is the limiting reagent in this case. So, $\text{NH}_3(\text{g})$ would be formed only from that amount of available dihydrogen *i.e.*, 4.96×10^3 mol

Since 3 mol $\text{H}_2(\text{g})$ gives 2 mol $\text{NH}_3(\text{g})$

$$4.96 \times 10^3 \text{ mol H}_2(\text{g}) \times \frac{2 \text{ mol NH}_3(\text{g})}{3 \text{ mol H}_2(\text{g})}$$

$$= 3.30 \times 10^3 \text{ mol NH}_3(\text{g})$$

3.30×10^3 mol $\text{NH}_3(\text{g})$ is obtained.

If they are to be converted to grams, it is done as follows :

$$1 \text{ mol NH}_3(\text{g}) = 17.0 \text{ g NH}_3(\text{g})$$

$$3.30 \times 10^3 \text{ mol NH}_3(\text{g}) \times \frac{17.0 \text{ g NH}_3(\text{g})}{1 \text{ mol NH}_3(\text{g})}$$

$$\begin{aligned}
 &= 3.30 \times 10^3 \times 17 \text{ g NH}_3 \text{ (g)} \\
 &= 56.1 \times 10^3 \text{ g NH}_3 \\
 &= 56.1 \text{ kg NH}_3
 \end{aligned}$$

1. Mass per cent

It is obtained by using the following relation:

$$\text{Mass per cent} = \frac{\text{Mass of solute}}{\text{Mass of solution}} \times 100$$

Problem 1.6

A solution is prepared by adding 2 g of a substance A to 18 g of water. Calculate the mass per cent of the solute.

Solution

$$\begin{aligned}
 \text{Mass per cent of A} &= \frac{\text{Mass of A}}{\text{Mass of solution}} \times 100 \\
 &= \frac{2 \text{ g}}{2 \text{ g of A} + 18 \text{ g of water}} \times 100 \\
 &= \frac{2 \text{ g}}{20 \text{ g}} \times 100 \\
 &= 10\%
 \end{aligned}$$

2. Mole Fraction

It is the ratio of number of moles of a particular component to the total number of moles of the solution. If a substance 'A' dissolves in substance 'B' and their number of moles are n_A and n_B , respectively, then the mole fractions of A and B are given as:

$$\begin{aligned}
 &\text{Mole fraction of A} \\
 &= \frac{\text{No. of moles of A}}{\text{No. of moles of solutions}} \\
 &= \frac{n_A}{n_A + n_B} \\
 &\text{Mole fraction of B} \\
 &= \frac{\text{No. of moles of B}}{\text{No. of moles of solutions}} \\
 &= \frac{n_B}{n_A + n_B}
 \end{aligned}$$

3. Molarity

It is the most widely used unit and is denoted by M. It is defined as the number of moles of the solute in 1 litre of the solution. Thus,

$$\text{Molarity (M)} = \frac{\text{No. of moles of solute}}{\text{Volume of solution in litres}}$$

Suppose, we have 1 M solution of a substance, say NaOH, and we want to prepare a 0.2 M solution from it.

1 M NaOH means 1 mol of NaOH present in 1 litre of the solution. For 0.2 M solution, we require 0.2 moles of NaOH dissolved in 1 litre solution.

Hence, for making 0.2M solution from 1M solution, we have to take that volume of 1M NaOH solution, which contains 0.2 mol of NaOH and dilute the solution with water to 1 litre.

Now, how much volume of concentrated (1M) NaOH solution be taken, which contains 0.2 moles of NaOH can be calculated as follows:

If 1 mol is present in 1L or 1000 mL solution

then, 0.2 mol is present in

$$\frac{1000 \text{ mL}}{1 \text{ mol}} \times 0.2 \text{ mol solution}$$

$$= 200 \text{ mL solution}$$

Thus, 200 mL of 1M NaOH are taken and enough water is added to dilute it to make it 1 litre.

In fact for such calculations, a general formula, $M_1 \times V_1 = M_2 \times V_2$ where M and V are molarity and volume, respectively, can be used. In this case, M_1 is equal to 0.2M; $V_1 = 1000$ mL and, $M_2 = 1.0\text{M}$; V_2 is to be calculated. Substituting the values in the formula:

$$0.2 \text{ M} \times 1000 \text{ mL} = 1.0 \text{ M} \times V_2$$

$$\therefore V_2 = \frac{0.2 \text{ M} \times 1000 \text{ mL}}{1.0 \text{ M}} = 200 \text{ L}$$

Note that the **number of moles of solute** (NaOH) was 0.2 in 200 mL and *it has remained the same*, i.e., 0.2 even after dilution (in 1000 mL) as we have changed just the amount of solvent (i.e., water) and have not done anything with respect to NaOH. But keep in mind the concentration.

Problem 1.7

Calculate the molarity of NaOH in the solution prepared by dissolving its 4 g in enough water to form 250 mL of the solution.

Solution

Since molarity (M)

$$= \frac{\text{No. of moles of solute}}{\text{Volume of solution in litres}}$$

$$= \frac{\text{Mass of NaOH} / \text{Molar mass of NaOH}}{0.250\text{L}}$$

$$= \frac{4\text{ g} / 40\text{ g}}{0.250\text{L}} = \frac{0.1\text{ mol}}{0.250\text{L}}$$

$$= 0.4\text{ mol}^{-1}$$

$$= 0.4\text{ M}$$

Note that molarity of a solution depends upon temperature because volume of a solution is temperature dependent.

Problem 1.8

The density of 3 M solution of NaCl is 1.25 g mL^{-1} . Calculate the molality of the solution.

Solution

$$M = 3\text{ mol L}^{-1}$$

$$\text{Mass of NaCl in 1 L solution} = 3 \times 58.5 = 175.5\text{ g}$$

$$\begin{aligned} \text{Mass of 1L solution} &= 1000 \times 1.25 = 1250\text{ g} \\ \text{(since density} &= 1.25\text{ g mL}^{-1}\text{)} \\ \text{Mass of water in solution} &= 1250 - 175.5 \\ &= 1074.5\text{ g} \end{aligned}$$

$$\begin{aligned} \text{Molality} &= \frac{\text{No. of moles of solute}}{\text{Mass of solvent in kg}} \\ &= \frac{3\text{ mol}}{1.0745\text{ kg}} = 2.79\text{ m} \end{aligned}$$

Often in a chemistry laboratory, a solution of a desired concentration is prepared by diluting a solution of known higher concentration. The solution of higher concentration is also known as stock solution. Note that the molality of a solution does not change with temperature since mass remains unaffected with temperature.

4. Molality

It is defined as the number of moles of solute present in 1 kg of solvent. It is denoted by m.

$$\text{Thus, Molality (m)} = \frac{\text{No. of moles of solute}}{\text{Mass of solvent in kg}}$$

SUMMARY

Chemistry, as we understand it today is not a very old discipline. People in ancient India, already had the knowledge of many scientific phenomenon much before the advent of modern science. They applied the knowledge in various walks of life.

The study of chemistry is very important as its domain encompasses every sphere of life. Chemists study the properties and structure of substances and the changes undergone by them. All substances contain matter, which can exist in three states – solid, liquid or gas. The constituent particles are held in different ways in these states of matter and they exhibit their characteristic properties. Matter can also be classified into elements, compounds or mixtures. An **element** contains particles of only one type, which may be **atoms** or **molecules**. The compounds are formed where atoms of two or more elements combine in a fixed ratio to each other. Mixtures occur widely and many of the substances present around us are mixtures.

When the properties of a substance are studied, measurement is inherent. The quantification of properties requires a system of measurement and units in which the quantities are to be expressed. Many systems of measurement exist, of which the English

and the Metric Systems are widely used. The scientific community, however, has agreed to have a uniform and common system throughout the world, which is abbreviated as SI units (International System of Units).

Since measurements involve recording of data, which are always associated with a certain amount of uncertainty, the proper handling of data obtained by measuring the quantities is very important. The measurements of quantities in chemistry are spread over a wide range of 10^{-31} to 10^{+23} . Hence, a convenient system of expressing the numbers in **scientific notation** is used. The uncertainty is taken care of by specifying the number of **significant figures**, in which the observations are reported. The **dimensional analysis** helps to express the measured quantities in different systems of units. Hence, it is possible to interconvert the results from one system of units to another.

The combination of different atoms is governed by basic laws of chemical combination — these being the **Law of Conservation of Mass, Law of Definite Proportions, Law of Multiple Proportions, Gay Lussac's Law of Gaseous Volumes** and **Avogadro Law**. All these laws led to the **Dalton's atomic theory**, which states that atoms are building blocks of matter. The **atomic mass** of an element is expressed relative to ^{12}C isotope of carbon, which has an exact value of 12u. Usually, the atomic mass used for an element is the **average atomic mass** obtained by taking into account the natural abundance of different isotopes of that element. The **molecular mass** of a molecule is obtained by taking sum of the atomic masses of different atoms present in a molecule. The **molecular formula** can be calculated by determining the mass per cent of different elements present in a compound and its molecular mass.

The number of atoms, molecules or any other particles present in a given system are expressed in the terms of **Avogadro constant** (6.022×10^{23}). This is known as **1 mol** of the respective particles or entities.

Chemical reactions represent the chemical changes undergone by different elements and compounds. A **balanced** chemical equation provides a lot of information. The coefficients indicate the molar ratios and the respective number of particles taking part in a particular reaction. The quantitative study of the reactants required or the products formed is called **stoichiometry**. Using stoichiometric calculations, the amount of one or more reactant(s) required to produce a particular amount of product can be determined and vice-versa. The amount of substance present in a given volume of a solution is expressed in number of ways, e.g., mass per cent, mole fraction, molarity and molality.

EXERCISES

- 1.1 Calculate the molar mass of the following:
(i) H_2O (ii) CO_2 (iii) CH_4
- 1.2 Calculate the mass per cent of different elements present in sodium sulphate (Na_2SO_4).
- 1.3 Determine the empirical formula of an oxide of iron, which has 69.9% iron and 30.1% dioxygen by mass.
- 1.4 Calculate the amount of carbon dioxide that could be produced when
 - (i) 1 mole of carbon is burnt in air.
 - (ii) 1 mole of carbon is burnt in 16 g of dioxygen.
 - (iii) 2 moles of carbon are burnt in 16 g of dioxygen.
- 1.5 Calculate the mass of sodium acetate (CH_3COONa) required to make 500 mL of 0.375 molar aqueous solution. Molar mass of sodium acetate is $82.0245 \text{ g mol}^{-1}$.

- 1.6 Calculate the concentration of nitric acid in moles per litre in a sample which has a density, 1.41 g mL^{-1} and the mass per cent of nitric acid in it being 69%.
- 1.7 How much copper can be obtained from 100 g of copper sulphate (CuSO_4)?
- 1.8 Determine the molecular formula of an oxide of iron, in which the mass per cent of iron and oxygen are 69.9 and 30.1, respectively.
- 1.9 Calculate the atomic mass (average) of chlorine using the following data:

	% Natural Abundance	Molar Mass
^{35}Cl	75.77	34.9689
^{37}Cl	24.23	36.9659

- 1.10 In three moles of ethane (C_2H_6), calculate the following:
- Number of moles of carbon atoms.
 - Number of moles of hydrogen atoms.
 - Number of molecules of ethane.
- 1.11 What is the concentration of sugar ($\text{C}_{12}\text{H}_{22}\text{O}_{11}$) in mol L^{-1} if its 20 g are dissolved in enough water to make a final volume up to 2L?
- 1.12 If the density of methanol is 0.793 kg L^{-1} , what is its volume needed for making 2.5 L of its 0.25 M solution?
- 1.13 Pressure is determined as force per unit area of the surface. The SI unit of pressure, pascal is as shown below:
- $1\text{Pa} = 1\text{N m}^{-2}$
- If mass of air at sea level is 1034 g cm^{-2} , calculate the pressure in pascal.
- 1.14 What is the SI unit of mass? How is it defined?
- 1.15 Match the following prefixes with their multiples:

	Prefixes	Multiples
(i)	micro	10^6
(ii)	deca	10^9
(iii)	mega	10^{-6}
(iv)	giga	10^{-15}
(v)	femto	10

- 1.16 What do you mean by significant figures?
- 1.17 A sample of drinking water was found to be severely contaminated with chloroform, CHCl_3 , supposed to be carcinogenic in nature. The level of contamination was 15 ppm (by mass).
- Express this in per cent by mass.
 - Determine the molality of chloroform in the water sample.
- 1.18 Express the following in the scientific notation:
- 0.0048
 - 234,000
 - 8008
 - 500.0
 - 6.0012
- 1.19 How many significant figures are present in the following?
- 0.0025
 - 208
 - 5005

- (iv) 126,000
 (v) 500.0
 (vi) 2.0034
- 1.20 Round up the following upto three significant figures:
 (i) 34.216
 (ii) 10.4107
 (iii) 0.04597
 (iv) 2808
- 1.21 The following data are obtained when dinitrogen and dioxygen react together to form different compounds:
- | | Mass of dinitrogen | Mass of dioxygen |
|-------|--------------------|------------------|
| (i) | 14 g | 16 g |
| (ii) | 14 g | 32 g |
| (iii) | 28 g | 32 g |
| (iv) | 28 g | 80 g |
- (a) Which law of chemical combination is obeyed by the above experimental data? Give its statement.
- (b) Fill in the blanks in the following conversions:
 (i) 1 km = mm = pm
 (ii) 1 mg = kg = ng
 (iii) 1 mL = L = dm³
- 1.22 If the speed of light is 3.0×10^8 m s⁻¹, calculate the distance covered by light in 2.00 ns.
- 1.23 In a reaction
 $A + B_2 \rightarrow AB_2$
 Identify the limiting reagent, if any, in the following reaction mixtures.
 (i) 300 atoms of A + 200 molecules of B
 (ii) 2 mol A + 3 mol B
 (iii) 100 atoms of A + 100 molecules of B
 (iv) 5 mol A + 2.5 mol B
 (v) 2.5 mol A + 5 mol B
- 1.24 Dinitrogen and dihydrogen react with each other to produce ammonia according to the following chemical equation:
 $N_2(g) + H_2(g) \rightarrow 2NH_3(g)$
 (i) Calculate the mass of ammonia produced if 2.00×10^3 g dinitrogen reacts with 1.00×10^3 g of dihydrogen.
 (ii) Will any of the two reactants remain unreacted?
 (iii) If yes, which one and what would be its mass?
- 1.25 How are 0.50 mol Na₂CO₃ and 0.50 M Na₂CO₃ different?
- 1.26 If 10 volumes of dihydrogen gas reacts with five volumes of dioxygen gas, how many volumes of water vapour would be produced?
- 1.27 Convert the following into basic units:
 (i) 28.7 pm
 (ii) 15.15 pm
 (iii) 25365 mg

- 1.28 Which one of the following will have the largest number of atoms?
 (i) 1 g Au (s)
 (ii) 1 g Na (s)
 (iii) 1 g Li (s)
 (iv) 1 g of Cl₂(g)
- 1.29 Calculate the molarity of a solution of ethanol in water, in which the mole fraction of ethanol is 0.040 (assume the density of water to be one).
- 1.30 What will be the mass of one ¹²C atom in g?
- 1.31 How many significant figures should be present in the answer of the following calculations?
 (i) $\frac{0.02856 \times 298.15 \times 0.112}{0.5785}$ (ii) 5×5.364
 (iii) $0.0125 + 0.7864 + 0.0215$
- 1.32 Use the data given in the following table to calculate the molar mass of naturally occurring argon isotopes:
- | Isotope | Isotopic molar mass | Abundance |
|------------------|------------------------------|-----------|
| ³⁶ Ar | 35.96755 g mol ⁻¹ | 0.337% |
| ³⁸ Ar | 37.96272 g mol ⁻¹ | 0.063% |
| ⁴⁰ Ar | 39.9624 g mol ⁻¹ | 99.600% |
- 1.33 Calculate the number of atoms in each of the following (i) 52 moles of Ar (ii) 52 u of He (iii) 52 g of He.
- 1.34 A welding fuel gas contains carbon and hydrogen only. Burning a small sample of it in oxygen gives 3.38 g carbon dioxide, 0.690 g of water and no other products. A volume of 10.0 L (measured at STP) of this welding gas is found to weigh 11.6 g. Calculate (i) empirical formula, (ii) molar mass of the gas, and (iii) molecular formula.
- 1.35 Calcium carbonate reacts with aqueous HCl to give CaCl₂ and CO₂ according to the reaction, CaCO₃ (s) + 2 HCl (aq) → CaCl₂ (aq) + CO₂(g) + H₂O(l)
 What mass of CaCO₃ is required to react completely with 25 mL of 0.75 M HCl?
- 1.36 Chlorine is prepared in the laboratory by treating manganese dioxide (MnO₂) with aqueous hydrochloric acid according to the reaction
 $4 \text{HCl (aq)} + \text{MnO}_2(\text{s}) \rightarrow 2\text{H}_2\text{O (l)} + \text{MnCl}_2(\text{aq}) + \text{Cl}_2(\text{g})$
 How many grams of HCl react with 5.0 g of manganese dioxide?



11082CH02

UNIT 2

STRUCTURE OF ATOM

Objectives

After studying this unit you will be able to

- know about the discovery of electron, proton and neutron and their characteristics;
- describe Thomson, Rutherford and Bohr atomic models;
- understand the important features of the quantum mechanical model of atom;
- understand nature of electromagnetic radiation and Planck's quantum theory;
- explain the photoelectric effect and describe features of atomic spectra;
- state the de Broglie relation and Heisenberg uncertainty principle;
- define an atomic orbital in terms of quantum numbers;
- state aufbau principle, Pauli exclusion principle and Hund's rule of maximum multiplicity; and
- write the electronic configurations of atoms.

“*The rich diversity of chemical behaviour of different elements can be traced to the differences in the internal structure of atoms of these elements.*”

The existence of atoms has been proposed since the time of early Indian and Greek philosophers (400 B.C.) who were of the view that atoms are the fundamental building blocks of matter. According to them, the continued subdivisions of matter would ultimately yield atoms which would not be further divisible. The word 'atom' has been derived from the Greek word '*a-tomio*' which means 'uncut-able' or 'non-divisible'. These earlier ideas were mere speculations and there was no way to test them experimentally. These ideas remained dormant for a very long time and were revived again by scientists in the nineteenth century.

The atomic theory of matter was first proposed on a firm scientific basis by John Dalton, a British school teacher in 1808. His theory, called **Dalton's atomic theory**, regarded the atom as the ultimate particle of matter (Unit 1). Dalton's atomic theory was able to explain the law of conservation of mass, law of constant composition and law of multiple proportion very successfully. However, it failed to explain the results of many experiments, for example, it was known that substances like glass or ebonite when rubbed with silk or fur get electrically charged.

In this unit we start with the experimental observations made by scientists towards the end of nineteenth and beginning of twentieth century. These established that atoms are made of sub-atomic particles, i.e., electrons, protons and neutrons — a concept very different from that of Dalton.

2.1 DISCOVERY OF SUB-ATOMIC PARTICLES

An insight into the structure of atom was obtained from the experiments on electrical discharge through gases. Before we discuss these results we need to keep in mind a basic rule regarding the behaviour of charged particles : “Like charges repel each other and unlike charges attract each other”.

2.1.1 Discovery of Electron

In 1830, Michael Faraday showed that if electricity is passed through a solution of an electrolyte, chemical reactions occurred at the electrodes, which resulted in the liberation and deposition of matter at the electrodes. He formulated certain laws which you will study in Class XII. These results suggested the particulate nature of electricity.

In mid 1850s many scientists mainly Faraday began to study electrical discharge in partially evacuated tubes, known as **cathode ray discharge tubes**. It is depicted in Fig. 2.1. A cathode ray tube is made of glass containing two thin pieces of metal, called electrodes, sealed in it. The electrical discharge through the gases could be observed only at very low pressures and at very high voltages. The pressure of different gases could be adjusted by evacuation of the glass tubes. When sufficiently high voltage is applied across the electrodes, current starts flowing through a stream of particles moving in the tube from the negative electrode (cathode) to the positive electrode (anode). These were called **cathode rays or cathode ray particles**. The flow of current from cathode to anode was further checked by making a hole in the anode and coating the tube behind anode with phosphorescent material zinc sulphide. When these rays, after passing through anode, strike the zinc sulphide coating, a bright spot is developed on the coating [Fig. 2.1(b)].

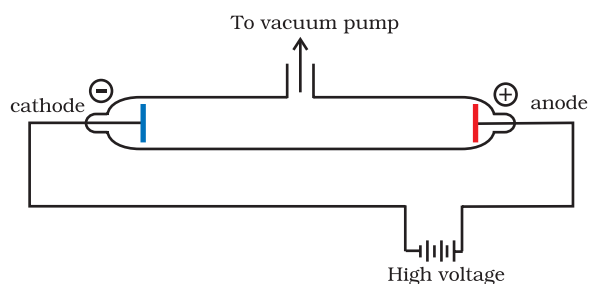

Fig. 2.1(a) A cathode ray discharge tube

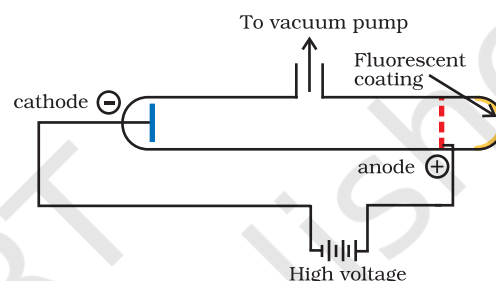

Fig. 2.1(b) A cathode ray discharge tube with perforated anode

The results of these experiments are summarised below.

- (i) The cathode rays start from cathode and move towards the anode.
- (ii) These rays themselves are not visible but their behaviour can be observed with the help of certain kind of materials (fluorescent or phosphorescent) which glow when hit by them. Television picture tubes are cathode ray tubes and television pictures result due to fluorescence on the television screen coated with certain fluorescent or phosphorescent materials.
- (iii) In the absence of electrical or magnetic field, these rays travel in straight lines (Fig. 2.2).
- (iv) In the presence of electrical or magnetic field, the behaviour of cathode rays are similar to that expected from negatively charged particles, suggesting that the cathode rays consist of negatively charged particles, called **electrons**.
- (v) The characteristics of cathode rays (electrons) do not depend upon the

material of electrodes and the nature of the gas present in the cathode ray tube.

Thus, we can conclude that electrons are basic constituent of all the atoms.

2.1.2 Charge to Mass Ratio of Electron

In 1897, British physicist J.J. Thomson measured the ratio of electrical charge (e) to the mass of electron (m_e) by using cathode ray tube and applying electrical and magnetic field perpendicular to each other as well as to the path of electrons (Fig. 2.2). When only electric field is applied, the electrons deviate from their path and hit the cathode ray tube at point A (Fig. 2.2). Similarly when only magnetic field is applied, electron strikes the cathode ray tube at point C. By carefully balancing the electrical and magnetic field strength, it is possible to bring back the electron to the path which is followed in the absence of electric or magnetic field and they hit the screen at point B. Thomson argued that the amount of deviation of the particles from their path in the presence of electrical or magnetic field depends upon:

- (i) the magnitude of the negative charge on the particle, greater the magnitude of the charge on the particle, greater is the interaction with the electric or magnetic field and thus greater is the deflection.
- (ii) the mass of the particle — lighter the particle, greater the deflection.

- (iii) the strength of the electrical or magnetic field — the deflection of electrons from its original path increases with the increase in the voltage across the electrodes, or the strength of the magnetic field.

By carrying out accurate measurements on the amount of deflections observed by the electrons on the electric field strength or magnetic field strength, Thomson was able to determine the value of e/m_e as:

$$\frac{e}{m_e} = 1.758820 \times 10^{11} \text{ C kg}^{-1} \quad (2.1)$$

Where m_e is the mass of the electron in kg and e is the magnitude of the charge on the electron in coulomb (C). Since electrons are negatively charged, the charge on electron is $-e$.

2.1.3 Charge on the Electron

R.A. Millikan (1868-1953) devised a method known as oil drop experiment (1906-14), to determine the charge on the electrons. He found the charge on the electron to be -1.6×10^{-19} C. The present accepted value of electrical charge is $-1.602176 \times 10^{-19}$ C. The mass of the electron (m_e) was determined by combining these results with Thomson's value of e/m_e ratio.

$$\begin{aligned} m_e &= \frac{e}{e/m_e} = \frac{1.602176 \times 10^{-19} \text{ C}}{1.758820 \times 10^{11} \text{ C kg}^{-1}} \\ &= 9.1094 \times 10^{-31} \text{ kg} \end{aligned} \quad (2.2)$$

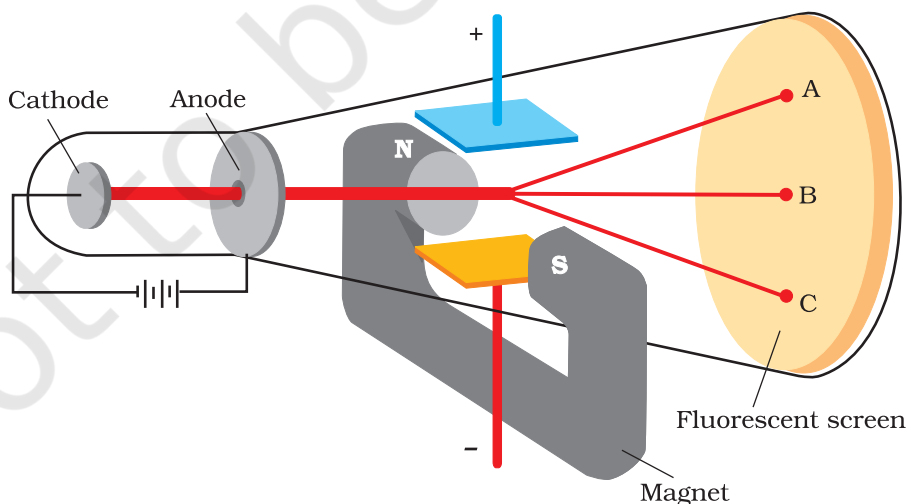

Fig. 2.2 The apparatus to determine the charge to the mass ratio of electron

2.1.4 Discovery of Protons and Neutrons

Electrical discharge carried out in the modified cathode ray tube led to the discovery of **canal rays** carrying positively charged particles. The characteristics of these positively charged particles are listed below.

- Unlike cathode rays, mass of positively charged particles depends upon the nature of gas present in the cathode ray tube. These are simply the positively charged gaseous ions.
- The charge to mass ratio of the particles depends on the gas from which these originate.
- Some of the positively charged particles carry a multiple of the fundamental unit of electrical charge.
- The behaviour of these particles in the magnetic or electrical field is opposite to that observed for electron or cathode rays.

The smallest and lightest positive ion was obtained from hydrogen and was called **proton**. This positively charged particle was characterised in 1919. Later, a need was felt for the presence of electrically neutral particle as one of the constituent of atom. These particles were discovered by Chadwick (1932) by bombarding a thin sheet of beryllium by α -particles. When electrically neutral particles having a mass slightly greater than that of protons were emitted. He named these particles as **neutrons**. The important properties of all these fundamental particles are given in Table 2.1.

2.2 ATOMIC MODELS

Observations obtained from the experiments mentioned in the previous sections have suggested that Dalton's indivisible atom is composed of sub-atomic particles carrying positive and negative charges. The major problems before the scientists after the discovery of sub-atomic particles were:

- to account for the stability of atom,
- to compare the behaviour of elements in terms of both physical and chemical properties,

Millikan's Oil Drop Method

In this method, oil droplets in the form of mist, produced by the atomiser, were allowed to enter through a tiny hole in the upper plate of electrical condenser. The downward motion of these droplets was viewed through the telescope, equipped with a micrometer eye piece. By measuring the rate of fall of these droplets, Millikan was able to measure the mass of oil droplets. The air inside the chamber was ionized by passing a beam of X-rays through it. The electrical charge on these oil droplets was acquired by collisions with gaseous ions. The fall of these charged oil droplets can be retarded, accelerated or made stationary depending upon the charge on the droplets and the polarity and strength of the voltage applied to the plate. By carefully measuring the effects of electrical field strength on the motion of oil droplets, Millikan concluded that the magnitude of electrical charge, q , on the droplets is always an integral multiple of the electrical charge, e , that is, $q = n e$, where $n = 1, 2, 3, \dots$

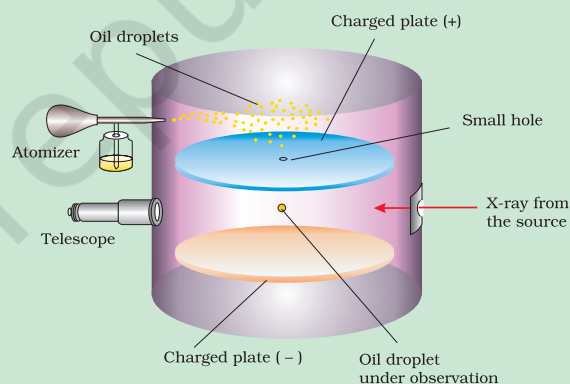

Fig. 2.3 The Millikan oil drop apparatus for measuring charge 'e'. In chamber, the forces acting on oil drop are: gravitational, electrostatic due to electrical field and a viscous drag force when the oil drop is moving.

- to explain the formation of different kinds of molecules by the combination of different atoms and,
- to understand the origin and nature of the characteristics of electromagnetic radiation absorbed or emitted by atoms.

Table 2.1 Properties of Fundamental Particles

Name	Symbol	Absolute charge/C	Relative charge	Mass/kg	Mass/u	Approx. mass/u
Electron	e	$-1.602176 \times 10^{-19}$	-1	9.109382×10^{-31}	0.00054	0
Proton	p	$+1.602176 \times 10^{-19}$	+1	$1.6726216 \times 10^{-27}$	1.00727	1
Neutron	n	0	0	1.674927×10^{-27}	1.00867	1

Different atomic models were proposed to explain the distributions of these charged particles in an atom. Although some of these models were not able to explain the stability of atoms, two of these models, one proposed by J.J. Thomson and the other proposed by Ernest Rutherford are discussed below.

2.2.1 Thomson Model of Atom

J. J. Thomson, in 1898, proposed that an atom possesses a spherical shape (radius approximately 10^{-10} m) in which the positive charge is uniformly distributed. The electrons are embedded into it in such a manner as to give the most stable electrostatic arrangement (Fig. 2.4). Many different names are given to this model, for example, **plum pudding**, **raisin pudding** or **watermelon**. This model

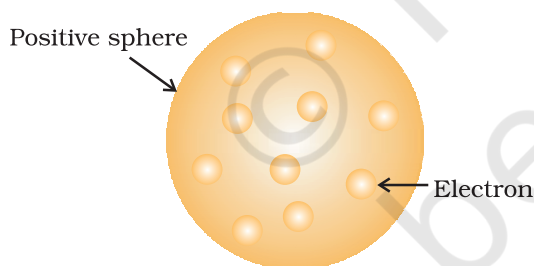

Fig.2.4 Thomson model of atom

can be visualised as a pudding or watermelon of positive charge with plums or seeds (electrons) embedded into it. *An important feature of this model is that the mass of the atom is assumed to be uniformly distributed over the atom.* Although this model was able to explain the overall neutrality of the atom, but was not consistent with the results of later experiments. Thomson was awarded Nobel Prize for physics in 1906, for his theoretical and experimental investigations on the conduction of electricity by gases.

In the later half of the nineteenth century different kinds of rays were discovered, besides those mentioned earlier. Wilhelm Röntgen (1845-1923) in 1895 showed that when electrons strike a material in the cathode ray tubes, produce rays which can cause fluorescence in the fluorescent materials placed outside the cathode ray tubes. Since Röntgen did not know the nature of the radiation, he named them X-rays and the name is still carried on. It was noticed that X-rays are produced effectively when electrons strike the dense metal anode, called targets. These are not deflected by the electric and magnetic fields and have a very high penetrating power through the matter and that is the reason that these rays are used to study the interior of the objects. These rays are of very short wavelengths (~ 0.1 nm) and possess electro-magnetic character (Section 2.3.1).

Henri Becquerel (1852-1908) observed that there are certain elements which emit radiation on their own and named this phenomenon as **radioactivity** and the elements known as **radioactive elements**. This field was developed by Marie Curie, Piere Curie, Rutherford and Fredrick Soddy. It was observed that three kinds of rays i.e., α , β - and γ -rays are emitted. Rutherford found that α -rays consists of high energy particles carrying two units of positive charge and four unit of atomic mass. He concluded that α - particles are helium nuclei as when α - particles combined with two electrons yielded helium gas. β -rays are negatively charged

particles similar to electrons. The γ -rays are high energy radiations like X-rays, are neutral in nature and do not consist of particles. As regards penetrating power, α -particles are the least, followed by β -rays (100 times that of α -particles) and γ -rays (1000 times of that α -particles).

2.2.2 Rutherford's Nuclear Model of Atom

Rutherford and his students (Hans Geiger and Ernest Marsden) bombarded very thin gold foil with α -particles. Rutherford's famous **α -particle scattering experiment** is

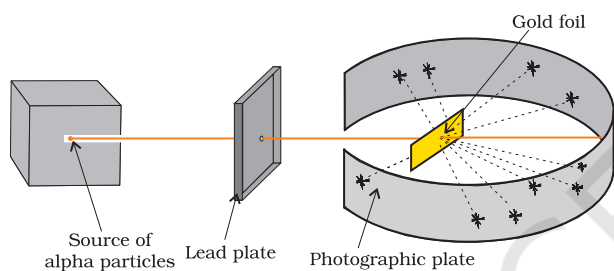

A. Rutherford's scattering experiment

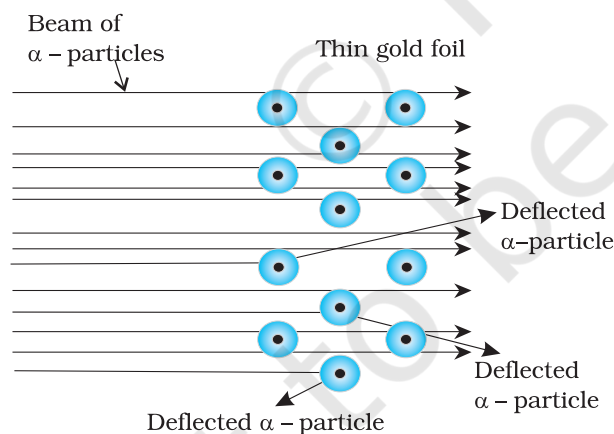

B. Schematic molecular view of the gold foil

Fig. 2.5 Schematic view of Rutherford's scattering experiment. When a beam of alpha (α) particles is "shot" at a thin gold foil, most of them pass through without much effect. Some, however, are deflected.

represented in Fig. 2.5. A stream of high energy α -particles from a radioactive source was directed at a thin foil (thickness ~ 100 nm) of gold metal. The thin gold foil had a circular fluorescent zinc sulphide screen around it. Whenever α -particles struck the screen, a tiny flash of light was produced at that point.

The results of scattering experiment were quite unexpected. According to Thomson model of atom, the mass of each gold atom in the foil should have been spread evenly over the entire atom, and α -particles had enough energy to pass directly through such a uniform distribution of mass. It was expected that the particles would slow down and change directions only by a small angles as they passed through the foil. It was observed that:

- (i) most of the α -particles passed through the gold foil undeflected.
- (ii) a small fraction of the α -particles was deflected by small angles.
- (iii) a very few α -particles (~ 1 in 20,000) bounced back, that is, were deflected by nearly 180° .

On the basis of the observations, Rutherford drew the following conclusions regarding the structure of atom:

- (i) Most of the space in the atom is empty as most of the α -particles passed through the foil undeflected.
- (ii) A few positively charged α -particles were deflected. The deflection must be due to enormous repulsive force showing that the positive charge of the atom is not spread throughout the atom as Thomson had presumed. The positive charge has to be concentrated in a very small volume that repelled and deflected the positively charged α -particles.
- (iii) Calculations by Rutherford showed that the volume occupied by the nucleus is negligibly small as compared to the total volume of the atom. The radius of the atom is about 10^{-10} m, while that of nucleus is 10^{-15} m. One can appreciate this difference in size by realising that if

a cricket ball represents a nucleus, then the radius of atom would be about 5 km.

On the basis of above observations and conclusions, Rutherford proposed the nuclear model of atom. According to this model:

- (i) The positive charge and most of the mass of the atom was densely concentrated in extremely small region. This very small portion of the atom was called **nucleus** by Rutherford.
- (ii) The nucleus is surrounded by electrons that move around the nucleus with a very high speed in circular paths called **orbits**. Thus, Rutherford's model of atom resembles the solar system in which the nucleus plays the role of sun and the electrons that of revolving planets.
- (iii) Electrons and the nucleus are held together by electrostatic forces of attraction.

2.2.3 Atomic Number and Mass Number

The presence of positive charge on the nucleus is due to the protons in the nucleus. As established earlier, the charge on the proton is equal but opposite to that of electron. The number of protons present in the nucleus is equal to atomic number (Z). For example, the number of protons in the hydrogen nucleus is 1, in sodium atom it is 11, therefore their atomic numbers are 1 and 11 respectively. In order to keep the electrical neutrality, the number of electrons in an atom is equal to the number of protons (atomic number, Z). For example, number of electrons in hydrogen atom and sodium atom are 1 and 11 respectively.

$$\begin{aligned} \text{Atomic number } (Z) &= \text{number of protons in} \\ &\quad \text{the nucleus of an atom} \\ &= \text{number of electrons} \\ &\quad \text{in a neutral atom} \quad (2.3) \end{aligned}$$

While the positive charge of the nucleus is due to protons, the mass of the nucleus, due to protons and neutrons. As discussed earlier protons and neutrons present in the nucleus are collectively known as **nucleons**.

The total number of nucleons is termed as **mass number (A)** of the atom.

$$\begin{aligned} \text{mass number } (A) &= \text{number of protons } (Z) \\ &+ \text{number of} \\ &\quad \text{neutrons } (n) \quad (2.4) \end{aligned}$$

2.2.4 Isobars and Isotopes

The composition of any atom can be represented by using the normal element symbol (X) with super-script on the left hand side as the atomic mass number (A) and subscript (Z) on the left hand side as the atomic number (i.e., ${}^A_Z X$).

Isobars are the atoms with same mass number but different atomic number for example, ${}^{14}_6\text{C}$ and ${}^{14}_7\text{N}$. On the other hand, atoms with identical atomic number but different atomic mass number are known as **isotopes**. In other words (according to equation 2.4), it is evident that difference between the isotopes is due to the presence of different number of neutrons present in the nucleus. For example, considering of hydrogen atom again, 99.985% of hydrogen atoms contain only one proton. This isotope is called **protium** (${}^1_1\text{H}$). Rest of the percentage of hydrogen atom contains two other isotopes, the one containing 1 proton and 1 neutron is called **deuterium** (${}^2_1\text{D}$, 0.015%) and the other one possessing 1 proton and 2 neutrons is called **tritium** (${}^3_1\text{T}$). The latter isotope is found in trace amounts on the earth. Other examples of commonly occurring isotopes are: carbon atoms containing 6, 7 and 8 neutrons besides 6 protons (${}^{12}_6\text{C}$, ${}^{13}_6\text{C}$, ${}^{14}_6\text{C}$); chlorine atoms containing 18 and 20 neutrons besides 17 protons (${}^{35}_{17}\text{Cl}$, ${}^{37}_{17}\text{Cl}$).

Lastly an important point to mention regarding isotopes is that *chemical properties of atoms are controlled by the number of electrons, which are determined by the number of protons in the nucleus*. Number of neutrons present in the nucleus have very little effect on the chemical properties of an element. Therefore, all the isotopes of a given element show same chemical behaviour.

Problem 2.1

Calculate the number of protons, neutrons and electrons in ${}_{35}^{80}\text{Br}$.

Solution

In this case, ${}_{35}^{80}\text{Br}$, $Z = 35$, $A = 80$, species is neutral

Number of protons = number of electrons
= $Z = 35$

Number of neutrons = $80 - 35 = 45$,
(equation 2.4)

Problem 2.2

The number of electrons, protons and neutrons in a species are equal to 18, 16 and 16 respectively. Assign the proper symbol to the species.

Solution

The atomic number is equal to number of protons = 16. The element is sulphur (S).

Atomic mass number = number of protons + number of neutrons
= $16 + 16 = 32$

Species is not neutral as the number of protons is not equal to electrons. It is anion (negatively charged) with charge equal to excess electrons = $18 - 16 = 2$. Symbol is ${}_{16}^{32}\text{S}^{2-}$.

Note : Before using the notation ${}^A_Z\text{X}$, find out whether the species is a neutral atom, a cation or an anion. If it is a neutral atom, equation (2.3) is valid, i.e., number of protons = number of electrons = atomic number. If the species is an ion, determine whether the number of protons are larger (cation, positive ion) or smaller (anion, negative ion) than the number of electrons. Number of neutrons is always given by $A - Z$, whether the species is neutral or ion.

2.2.5 Drawbacks of Rutherford Model

As you have learnt above, Rutherford nuclear model of an atom is like a small scale solar system with the nucleus playing the role

of the massive sun and the electrons being similar to the lighter planets. When classical mechanics* is applied to the solar system, it shows that the planets describe well-defined orbits around the sun. The gravitational force between the planets is given by the expression

$$\left(G \cdot \frac{m_1 m_2}{r^2} \right)$$

where m_1 and m_2 are the masses, r is the distance of separation of the masses and G is the gravitational constant. The theory can also calculate precisely the planetary orbits and these are in agreement with the experimental measurements.

The similarity between the solar system and nuclear model suggests that electrons should move around the nucleus in well defined orbits. Further, the coulomb force (kq_1q_2/r^2 where q_1 and q_2 are the charges, r is the distance of separation of the charges and k is the proportionality constant) between electron and the nucleus is mathematically similar to the gravitational force. However, when a body is moving in an orbit, it undergoes acceleration even if it is moving with a constant speed in an orbit because of changing direction. So an electron in the nuclear model describing planet like orbits is under acceleration. According to the electromagnetic theory of Maxwell, charged particles when accelerated should emit electromagnetic radiation (This feature does not exist for planets since they are uncharged). Therefore, an electron in an orbit will emit radiation, the energy carried by radiation comes from electronic motion. The orbit will thus continue to shrink. Calculations show that it should take an electron only 10^{-8} s to spiral into the nucleus. But this does not happen. Thus, the Rutherford model cannot explain the stability of an atom. If the motion of an electron is described on the basis of the classical mechanics and electromagnetic theory, you may ask that since the motion of electrons in orbits is leading to the instability of the atom, then why not consider electrons as stationary

* Classical mechanics is a theoretical science based on Newton's laws of motion. It specifies the laws of motion of macroscopic objects.

around the nucleus. If the electrons were stationary, electrostatic attraction between the dense nucleus and the electrons would pull the electrons toward the nucleus to form a miniature version of Thomson's model of atom.

Another serious drawback of the Rutherford model is that it says nothing about distribution of the electrons around the nucleus and the energies of these electrons.

2.3 DEVELOPMENTS LEADING TO THE BOHR'S MODEL OF ATOM

Historically, results observed from the studies of interactions of radiations with matter have provided immense information regarding the structure of atoms and molecules. Neils Bohr utilised these results to improve upon the model proposed by Rutherford. Two developments played a major role in the formulation of Bohr's model of atom. These were:

- (i) Dual character of the electromagnetic radiation which means that radiations possess both wave like and particle like properties, and
- (ii) Experimental results regarding atomic spectra.

First, we will discuss about the dual nature of electromagnetic radiations. Experimental results regarding atomic spectra will be discussed in Section 2.4.

2.3.1 Wave Nature of Electromagnetic Radiation

In the mid-nineteenth century, physicists actively studied absorption and emission of radiation by heated objects. These are called thermal radiations. They tried to find out of what the thermal radiation is made. It is now a well-known fact that thermal radiations consist of electromagnetic waves of various frequencies or wavelengths. It is based on a number of modern concepts, which were unknown in the mid-nineteenth century. First active study of thermal radiation laws occurred in the 1850's and the theory of electromagnetic waves and the emission of such waves by accelerating charged particles

was developed in the early 1870's by James Clerk Maxwell, which was experimentally confirmed later by Heinrich Hertz. Here, we will learn some facts about electromagnetic radiations.

James Maxwell (1870) was the first to give a comprehensive explanation about the interaction between the charged bodies and the behaviour of electrical and magnetic fields on macroscopic level. He suggested that when electrically charged particle moves under acceleration, alternating electrical and magnetic fields are produced and transmitted. These fields are transmitted in the forms of waves called **electromagnetic waves** or **electromagnetic radiation**.

Light is the form of radiation known from early days and speculation about its nature dates back to remote ancient times. In earlier days (Newton) light was supposed to be made of particles (corpuscles). It was only in the 19th century when wave nature of light was established.

Maxwell was again the first to reveal that light waves are associated with oscillating electric and magnetic character (Fig. 2.6).

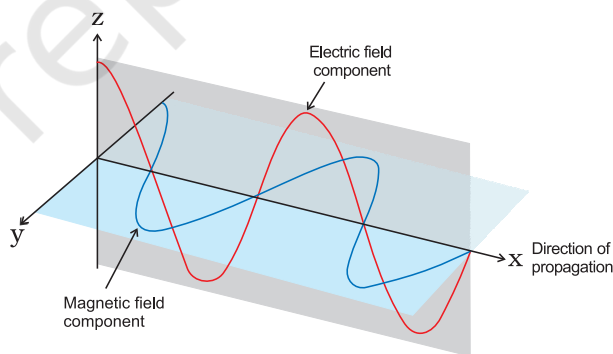

Fig.2.6 The electric and magnetic field components of an electromagnetic wave. These components have the same wavelength, frequency, speed and amplitude, but they vibrate in two mutually perpendicular planes.

Although electromagnetic wave motion is complex in nature, we will consider here only a few simple properties.

- (i) The oscillating electric and magnetic fields produced by oscillating charged

particles are perpendicular to each other and both are perpendicular to the direction of propagation of the wave. Simplified picture of electromagnetic wave is shown in Fig. 2.6.

- (ii) Unlike sound waves or waves produced in water, electromagnetic waves do not require medium and can move in vacuum.
- (iii) It is now well established that there are many types of electromagnetic radiations, which differ from one another in wavelength (or frequency). These constitute what is called **electromagnetic spectrum** (Fig. 2.7). Different regions of the spectrum are identified by different names. Some examples are: radio frequency region around 10^6 Hz, used for broadcasting; microwave region around 10^{10} Hz used for radar; infrared region around 10^{13} Hz used for heating; ultraviolet region around 10^{16} Hz a component of sun's radiation. The small portion around 10^{15} Hz, is what is ordinarily called **visible light**. It is only this part which our eyes can see (or detect). Special instruments are required to detect non-visible radiation.

- (iv) Different kinds of units are used to represent electromagnetic radiation.

These radiations are characterised by the properties, namely, frequency (ν) and wavelength (λ).

The SI unit for frequency (ν) is hertz (Hz, s^{-1}), after Heinrich Hertz. It is defined as the number of waves that pass a given point in one second.

Wavelength should have the units of length and as you know that the SI units of length is meter (m). Since electromagnetic radiation consists of different kinds of waves of much smaller wavelengths, smaller units are used. Fig. 2.7 shows various types of electro-magnetic radiations which differ from one another in wavelengths and frequencies.

In vacuum all types of electromagnetic radiations, regardless of wavelength, travel at the same speed, i.e., $3.0 \times 10^8 \text{ m s}^{-1}$ ($2.997925 \times 10^8 \text{ ms}^{-1}$, to be precise). This is called **speed of light** and is given the symbol 'c'. The frequency (ν), wavelength (λ) and velocity of light (c) are related by the equation (2.5).

$$c = \nu \lambda \quad (2.5)$$

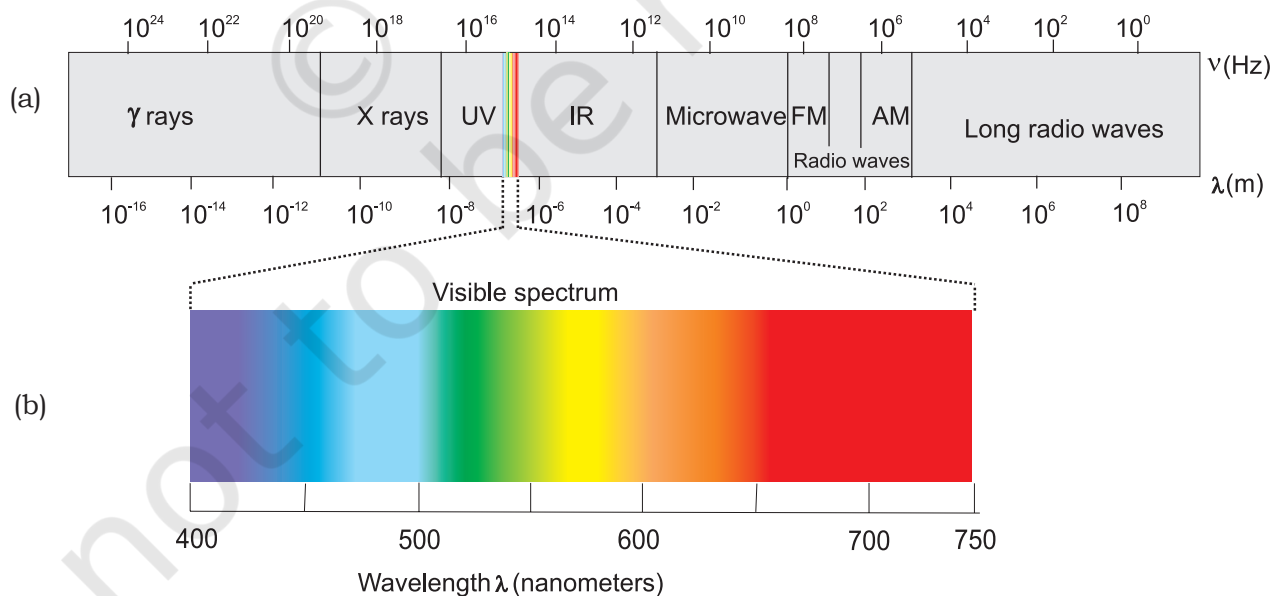

Fig. 2.7 (a) The spectrum of electromagnetic radiation. (b) Visible spectrum. The visible region is only a small part of the entire spectrum.

The other commonly used quantity specially in spectroscopy, is the **wavenumber** ($\bar{\nu}$). It is defined as the number of wavelengths per unit length. Its units are reciprocal of wavelength unit, i.e., m^{-1} . However commonly used unit is cm^{-1} (not SI unit).

Problem 2.3

The Vividh Bharati station of All India Radio, Delhi, broadcasts on a frequency of 1,368 kHz (kilo hertz). Calculate the wavelength of the electromagnetic radiation emitted by transmitter. Which part of the electromagnetic spectrum does it belong to?

Solution

The wavelength, λ , is equal to c/ν , where c is the speed of electromagnetic radiation in vacuum and ν is the frequency. Substituting the given values, we have

$$\begin{aligned}\lambda &= \frac{c}{\nu} \\ &= \frac{3.00 \times 10^8 \text{ m s}^{-1}}{1368 \text{ kHz}} \\ &= \frac{3.00 \times 10^8 \text{ m s}^{-1}}{1368 \times 10^3 \text{ s}^{-1}} \\ &= 219.3 \text{ m}\end{aligned}$$

This is a characteristic radiowave wavelength.

Problem 2.4

The wavelength range of the visible spectrum extends from violet (400 nm) to red (750 nm). Express these wavelengths in frequencies (Hz). ($1 \text{ nm} = 10^{-9} \text{ m}$)

Solution

Using equation 2.5, frequency of violet light

$$\begin{aligned}\nu &= \frac{c}{\lambda} = \frac{3.00 \times 10^8 \text{ m s}^{-1}}{400 \times 10^{-9} \text{ m}} \\ &= 7.50 \times 10^{14} \text{ Hz}\end{aligned}$$

Frequency of red light

$$\nu = \frac{c}{\lambda} = \frac{3.00 \times 10^8 \text{ m s}^{-1}}{750 \times 10^{-9} \text{ m}} = 4.00 \times 10^{14} \text{ Hz}$$

The range of visible spectrum is from 4.0×10^{14} to 7.5×10^{14} Hz in terms of frequency units.

Problem 2.5

Calculate (a) wavenumber and (b) frequency of yellow radiation having wavelength 5800 Å.

Solution

(a) Calculation of wavenumber ($\bar{\nu}$)
 $\lambda = 5800 \text{ Å} = 5800 \times 10^{-8} \text{ m}$
 $= 5800 \times 10^{-10} \text{ m}$

$$\begin{aligned}\bar{\nu} &= \frac{1}{\lambda} = \frac{1}{5800 \times 10^{-10} \text{ m}} \\ &= 1.724 \times 10^6 \text{ m}^{-1} \\ &= 1.724 \times 10^4 \text{ cm}^{-1}\end{aligned}$$

(b) Calculation of the frequency (ν)

$$\bar{\nu} = \frac{c}{\lambda} = \frac{3 \times 10^8 \text{ m s}^{-1}}{5800 \times 10^{-10} \text{ m}} = 5.172 \times 10^{14} \text{ s}^{-1}$$

2.3.2 Particle Nature of Electromagnetic Radiation: Planck's Quantum Theory

Some of the experimental phenomenon such as diffraction* and interference** can be explained by the wave nature of the electromagnetic radiation. However, following are some of the observations which could not be explained with the help of even the electromagnetic theory of 19th century physics (known as classical physics):

- the nature of emission of radiation from hot bodies (black-body radiation)
- ejection of electrons from metal surface when radiation strikes it (photoelectric effect)
- variation of heat capacity of solids as a function of temperature

* Diffraction is the bending of wave around an obstacle.

** Interference is the combination of two waves of the same or different frequencies to give a wave whose distribution at each point in space is the algebraic or vector sum of disturbances at that point resulting from each interfering wave.

(iv) Line spectra of atoms with special reference to hydrogen.

These phenomena indicate that the system can take energy only in discrete amounts. All possible energies cannot be taken up or radiated.

It is noteworthy that the first concrete explanation for the phenomenon of the black body radiation mentioned above was given by Max Planck in 1900. Let us first try to understand this phenomenon, which is given below:

Hot objects emit electromagnetic radiations over a wide range of wavelengths. At high temperatures, an appreciable proportion of radiation is in the visible region of the spectrum. As the temperature is raised, a higher proportion of short wavelength (blue light) is generated. For example, when an iron rod is heated in a furnace, it first turns to dull red and then progressively becomes more and more red as the temperature increases. As this is heated further, the radiation emitted becomes white and then becomes blue as the temperature becomes very high. This means that red radiation is most intense at a particular temperature and the blue radiation is more intense at another temperature. This means intensities of radiations of different wavelengths emitted by hot body depend upon its temperature. By late 1850's it was known that objects made of different material and kept at different temperatures emit different amount of radiation. Also, when the surface of an object is irradiated with light (electromagnetic radiation), a part of radiant energy is generally reflected as such, a part is absorbed and a part of it is transmitted. The reason for incomplete absorption is that ordinary objects are as a rule imperfect absorbers of radiation. *An ideal body, which emits and absorbs radiations of all frequencies uniformly, is called a black body and the radiation emitted by such a body is called black body radiation.* In practice, no such body exists. Carbon black approximates fairly closely to black body. A good physical approximation to a black body is a cavity with a tiny hole, which has no other opening. Any ray

entering the hole will be reflected by the cavity walls and will be eventually absorbed by the walls. A black body is also a perfect radiator of radiant energy. Furthermore, a black body is in thermal equilibrium with its surroundings. It radiates same amount of energy per unit area as it absorbs from its surrounding in any given time. The amount of light emitted (intensity of radiation) from a black body and its spectral distribution depends only on its temperature. At a given temperature, intensity of radiation emitted increases with the increase of wavelength, reaches a maximum value at a given wavelength and then starts decreasing with further increase of wavelength, as shown in Fig. 2.8. Also, as the temperature increases, maxima of the curve shifts to short wavelength. Several attempts were made to predict the intensity of radiation as a function of wavelength.

But the results of the above experiment could not be explained satisfactorily on the basis of the wave theory of light. Max Planck arrived at a satisfactory relationship

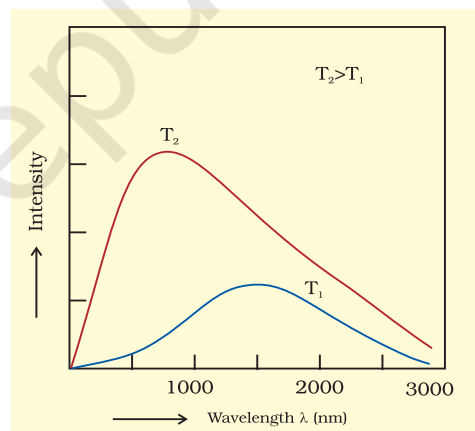

Fig. 2.8 Wavelength-intensity relationship

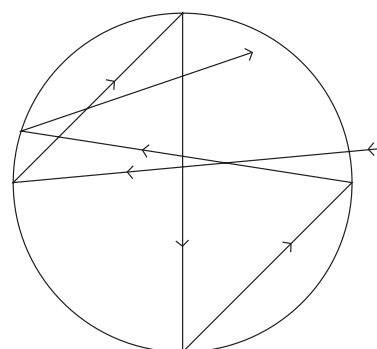

Fig. 2.8(a) Black body

by making an assumption that absorption and emission of radiation arises from oscillator i.e., atoms in the wall of black body. Their frequency of oscillation is changed by interaction with oscillators of electromagnetic radiation. Planck assumed that radiation could be sub-divided into discrete chunks of energy. He suggested that atoms and molecules could emit or absorb energy only in discrete quantities and not in a continuous manner. He gave the name **quantum** to the smallest quantity of energy that can be emitted or absorbed in the form of electromagnetic radiation. The energy (E) of a quantum of radiation is proportional to its frequency (ν) and is expressed by equation (2.6).

$$E = h\nu \quad (2.6)$$

The proportionality constant, ' h ' is known as Planck's constant and has the value 6.626×10^{-34} J s.

With this theory, Planck was able to explain the distribution of intensity in the radiation from black body as a function of frequency or wavelength at different temperatures.

Quantisation has been compared to standing on a staircase. A person can stand on any step of a staircase, but it is not possible for him/her to stand in between the two steps. The energy can take any one of the values from the following set, but cannot take on any values between them.

$$E = 0, h\nu, 2h\nu, 3h\nu, \dots, nh\nu, \dots$$

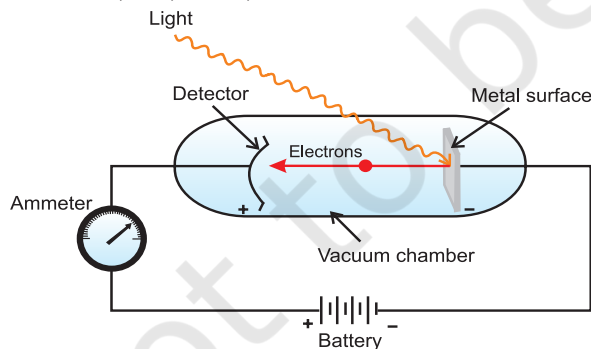

Fig.2.9 Equipment for studying the photoelectric effect. Light of a particular frequency strikes a clean metal surface inside a vacuum chamber. Electrons are ejected from the metal and are counted by a detector that measures their kinetic energy.



Max Planck (1858–1947)

Max Planck, a German physicist, received his Ph.D in theoretical physics from the University of Munich in 1879. In 1888, he was appointed Director of the Institute of Theoretical Physics at the University of Berlin.

Planck was awarded the Nobel Prize in Physics in 1918 for his quantum theory. Planck also made significant contributions in thermodynamics and other areas of physics.

Photoelectric Effect

In 1887, H. Hertz performed a very interesting experiment in which electrons (or electric current) were ejected when certain metals (for example potassium, rubidium, caesium etc.) were exposed to a beam of light as shown in Fig. 2.9. The phenomenon is called **Photoelectric effect**. The results observed in this experiment were:

- (i) The electrons are ejected from the metal surface as soon as the beam of light strikes the surface, i.e., there is no time lag between the striking of light beam and the ejection of electrons from the metal surface.
- (ii) The number of electrons ejected is proportional to the intensity or brightness of light.
- (iii) For each metal, there is a characteristic minimum frequency, ν_0 (also known as **threshold frequency**) below which photoelectric effect is not observed. At a frequency $\nu > \nu_0$, the ejected electrons come out with certain kinetic energy. The kinetic energies of these electrons increase with the increase of frequency of the light used.

All the above results could not be explained on the basis of laws of classical physics. According to latter, the energy content of the beam of light depends upon the brightness of the light. In other words, number of electrons ejected and kinetic energy associated with them should depend on the brightness of light. It has been observed that though the number

Table 2.2 Values of Work Function (W_0) for a Few Metals

Metal	Li	Na	K	Mg	Cu	Ag
W_0 /eV	2.42	2.3	2.25	3.7	4.8	4.3

of electrons ejected does depend upon the brightness of light, the kinetic energy of the ejected electrons does not. For example, red light [$\nu = (4.3 \text{ to } 4.6) \times 10^{14}$ Hz] of any brightness (intensity) may shine on a piece of potassium metal for hours but no photoelectrons are ejected. But, as soon as even a very weak yellow light ($\nu = 5.1\text{--}5.2 \times 10^{14}$ Hz) shines on the potassium metal, the photoelectric effect is observed. The threshold frequency (ν_0) for potassium metal is 5.0×10^{14} Hz.

Einstein (1905) was able to explain the photoelectric effect using Planck's quantum theory of electromagnetic radiation as a starting point.

Albert Einstein, a German born American physicist, is regarded by many as one of the two great physicists the world has known (the other is Isaac Newton). His three research papers (on special relativity, Brownian motion and the photoelectric effect) which he published in 1905, while he was employed as a technical assistant in a Swiss patent office in Berne have profoundly influenced the development of physics. He received the Nobel Prize in Physics in 1921 for his explanation of the photoelectric effect.

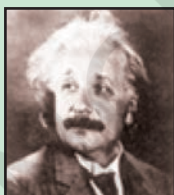

Albert Einstein
(1879–1955)

Shining a beam of light on to a metal surface can, therefore, be viewed as shooting a beam of particles, the photons. When a photon of sufficient energy strikes an electron in the atom of the metal, it transfers its energy instantaneously to the electron during the collision and the electron is ejected without any time lag or delay. Greater the energy possessed by the photon, greater will be transfer of energy to the electron and greater the kinetic energy of the ejected electron. In other words, kinetic energy of the ejected electron is proportional to the frequency of the electromagnetic radiation. Since the striking photon has energy equal to $h\nu$ and

the minimum energy required to eject the electron is $h\nu_0$ (also called work function, W_0 ; Table 2.2), then the difference in energy ($h\nu - h\nu_0$) is transferred as the kinetic energy of the photoelectron. Following the conservation of energy principle, the kinetic energy of the ejected electron is given by the equation 2.7.

$$h\nu = h\nu_0 + \frac{1}{2} m_e v^2 \quad (2.7)$$

where m_e is the mass of the electron and v is the velocity associated with the ejected electron. Lastly, a more intense beam of light consists of larger number of photons, consequently the number of electrons ejected is also larger as compared to that in an experiment in which a beam of weaker intensity of light is employed.

Dual Behaviour of Electromagnetic Radiation

The particle nature of light posed a dilemma for scientists. On the one hand, it could explain the black body radiation and photoelectric effect satisfactorily but on the other hand, it was not consistent with the known wave behaviour of light which could account for the phenomena of interference and diffraction. The only way to resolve the dilemma was to accept the idea that light possesses both particle and wave-like properties, i.e., light has dual behaviour. Depending on the experiment, we find that light behaves either as a wave or as a stream of particles. Whenever radiation interacts with matter, it displays particle like properties in contrast to the wavelike properties (interference and diffraction), which it exhibits when it propagates. This concept was totally alien to the way the scientists thought about matter and radiation and it took them a long time to become convinced of its validity. It turns out, as you shall see later, that some microscopic particles like electrons also exhibit this wave-particle duality.

Problem 2.6

Calculate energy of one mole of photons of radiation whose frequency is 5×10^{14} Hz.

Solution

Energy (E) of one photon is given by the expression

$$E = h\nu$$

$$h = 6.626 \times 10^{-34} \text{ J s}$$

$$\nu = 5 \times 10^{14} \text{ s}^{-1} \text{ (given)}$$

$$E = (6.626 \times 10^{-34} \text{ J s}) \times (5 \times 10^{14} \text{ s}^{-1}) \\ = 3.313 \times 10^{-19} \text{ J}$$

Energy of one mole of photons

$$= (3.313 \times 10^{-19} \text{ J}) \times (6.022 \times 10^{23} \text{ mol}^{-1}) \\ = 199.51 \text{ kJ mol}^{-1}$$

Problem 2.7

A 100 watt bulb emits monochromatic light of wavelength 400 nm. Calculate the number of photons emitted per second by the bulb.

Solution

$$\text{Power of the bulb} = 100 \text{ watt} \\ = 100 \text{ J s}^{-1}$$

Energy of one photon $E = h\nu = hc/\lambda$

$$= \frac{6.626 \times 10^{-34} \text{ J s} \times 3 \times 10^8 \text{ m s}^{-1}}{400 \times 10^{-9} \text{ m}}$$

$$= 4.969 \times 10^{-19} \text{ J}$$

Number of photons emitted

$$\frac{100 \text{ J s}^{-1}}{4.969 \times 10^{-19} \text{ J}} = 2.012 \times 10^{20} \text{ s}^{-1}$$

Problem 2.8

When electromagnetic radiation of wavelength 300 nm falls on the surface of sodium, electrons are emitted with a kinetic energy of $1.68 \times 10^5 \text{ J mol}^{-1}$. What is the minimum energy needed to remove an electron from sodium? What is the maximum wavelength that will cause a photoelectron to be emitted?

Solution

The energy (E) of a 300 nm photon is given by

$$h\nu = hc/\lambda \\ = \frac{6.626 \times 10^{-34} \text{ J s} \times 3.0 \times 10^8 \text{ m s}^{-1}}{300 \times 10^{-9} \text{ m}} \\ = 6.626 \times 10^{-19} \text{ J}$$

The energy of one mole of photons

$$= 6.626 \times 10^{-19} \text{ J} \times 6.022 \times 10^{23} \text{ mol}^{-1} \\ = 3.99 \times 10^5 \text{ J mol}^{-1}$$

The minimum energy needed to remove one mole of electrons from sodium

$$= (3.99 - 1.68) \times 10^5 \text{ J mol}^{-1} \\ = 2.31 \times 10^5 \text{ J mol}^{-1}$$

The minimum energy for one electron

$$= \frac{2.31 \times 10^5 \text{ J mol}^{-1}}{6.022 \times 10^{23} \text{ electrons mol}^{-1}} \\ = 3.84 \times 10^{-19} \text{ J}$$

This corresponds to the wavelength

$$\therefore \lambda = \frac{hc}{E} \\ = \frac{6.626 \times 10^{-34} \text{ J s} \times 3.0 \times 10^8 \text{ m s}^{-1}}{3.84 \times 10^{-19} \text{ J}} \\ = 517 \text{ nm}$$

(This corresponds to green light)

Problem 2.9

The threshold frequency ν_0 for a metal is $7.0 \times 10^{14} \text{ s}^{-1}$. Calculate the kinetic energy of an electron emitted when radiation of frequency $\nu = 1.0 \times 10^{15} \text{ s}^{-1}$ hits the metal.

Solution

According to Einstein's equation

$$\text{Kinetic energy} = \frac{1}{2} m_e v^2 = h(\nu - \nu_0) \\ = (6.626 \times 10^{-34} \text{ J s}) (1.0 \times 10^{15} \text{ s}^{-1} - 7.0 \\ \times 10^{14} \text{ s}^{-1}) \\ = (6.626 \times 10^{-34} \text{ J s}) (10.0 \times 10^{14} \text{ s}^{-1} - 7.0 \\ \times 10^{14} \text{ s}^{-1}) \\ = (6.626 \times 10^{-34} \text{ J s}) \times (3.0 \times 10^{14} \text{ s}^{-1}) \\ = 1.988 \times 10^{-19} \text{ J}$$

2.3.3 Evidence for the quantized* Electronic Energy Levels: Atomic spectra

The speed of light depends upon the nature of the medium through which it passes. As a result, the beam of light is deviated or refracted from its original path as it passes from one medium to another. It is observed that when a ray of white light is passed through a prism, the wave with shorter wavelength bends more than the one with a longer wavelength. Since ordinary white light consists of waves with all the wavelengths in the visible range, a ray of white light is spread out into a series of coloured bands called **spectrum**. The light of red colour which has longest wavelength is deviated the least while the violet light, which has shortest wavelength is deviated the most. The spectrum of white light, that we can see, ranges from violet at 7.50×10^{14} Hz to red at 4×10^{14} Hz. Such a spectrum is called **continuous spectrum**. Continuous because violet merges into blue, blue into green and so on. A similar spectrum is produced when a rainbow forms in the sky. Remember that visible light is just a small portion of the electromagnetic radiation (Fig.2.7). When electromagnetic radiation interacts with matter, atoms and molecules may absorb energy and reach to a higher energy state. With higher energy, these are in an unstable state. For returning to their normal (more stable, lower energy states) energy state, the atoms and molecules emit radiations in various regions of the electromagnetic spectrum.

Emission and Absorption Spectra

The spectrum of radiation emitted by a substance that has absorbed energy is called an **emission spectrum**. Atoms, molecules or ions that have absorbed radiation are said to be **“excited”**. To produce an emission spectrum, energy is supplied to a sample by heating it or irradiating it and the wavelength (or frequency) of the radiation emitted, as the sample gives up the absorbed energy, is recorded.

An absorption spectrum is like the photographic negative of an emission

spectrum. A continuum of radiation is passed through a sample which absorbs radiation of certain wavelengths. The missing wavelength which corresponds to the radiation absorbed by the matter, leave dark spaces in the bright continuous spectrum.

The study of emission or absorption spectra is referred to as **spectroscopy**. The spectrum of the visible light, as discussed above, was continuous as all wavelengths (red to violet) of the visible light are represented in the spectra. The emission spectra of atoms in the gas phase, on the other hand, do not show a continuous spread of wavelength from red to violet, rather they emit light only at specific wavelengths with dark spaces between them. Such spectra are called **line spectra** or **atomic spectra** because the emitted radiation is identified by the appearance of bright lines in the spectra (Fig. 2.10 page 45).

Line emission spectra are of great interest in the study of electronic structure. Each element has a unique line emission spectrum. The characteristic lines in atomic spectra can be used in chemical analysis to identify unknown atoms in the same way as fingerprints are used to identify people. The exact matching of lines of the emission spectrum of the atoms of a known element with the lines from an unknown sample quickly establishes the identity of the latter, German chemist, Robert Bunsen (1811-1899) was one of the first investigators to use line spectra to identify elements.

Elements like rubidium (Rb), caesium (Cs) thallium (Tl), indium (In), gallium (Ga) and scandium (Sc) were discovered when their minerals were analysed by spectroscopic methods. The element helium (He) was discovered in the sun by spectroscopic method.

Line Spectrum of Hydrogen

When an electric discharge is passed through gaseous hydrogen, the H_2 molecules dissociate and the energetically excited hydrogen atoms produced emit electromagnetic radiation of *discrete frequencies*. The hydrogen spectrum consists of several series of *lines* named after their discoverers. Balmer showed in 1885 on the basis of experimental observations

* The restriction of any property to discrete values is called quantization.

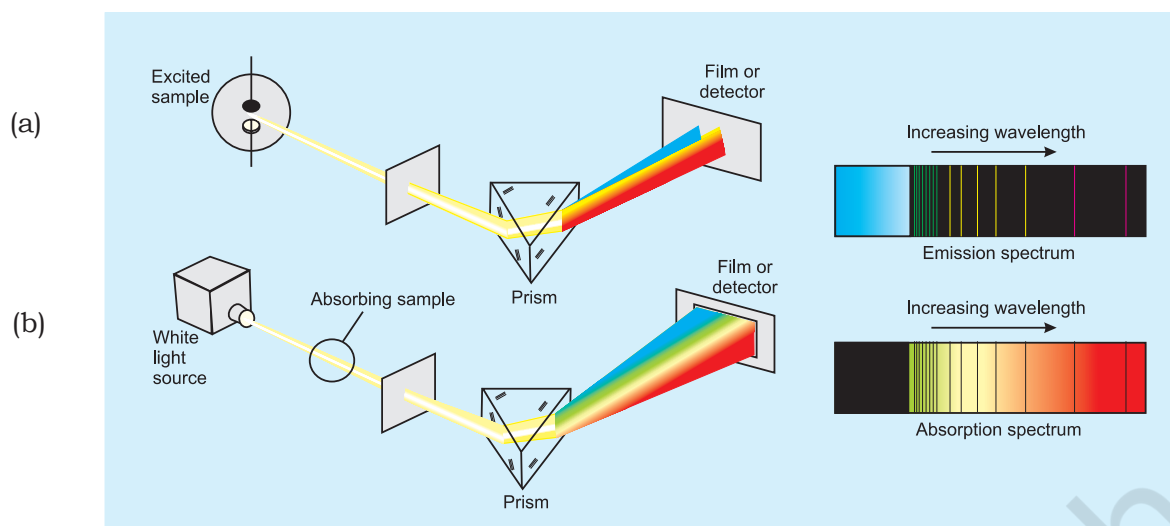

Fig. 2.10 (a) Atomic emission. The light emitted by a sample of excited hydrogen atoms (or any other element) can be passed through a prism and separated into certain discrete wavelengths. Thus an emission spectrum, which is a photographic recording of the separated wavelengths is called as line spectrum. Any sample of reasonable size contains an enormous number of atoms. Although a single atom can be in only one excited state at a time, the collection of atoms contains all possible excited states. The light emitted as these atoms fall to lower energy states is responsible for the spectrum. **(b) Atomic absorption.** When white light is passed through unexcited atomic hydrogen and then through a slit and prism, the transmitted light is lacking in intensity at the same wavelengths as are emitted in (a). The recorded absorption spectrum is also a line spectrum and the photographic negative of the emission spectrum.

that if spectral lines are expressed in terms of wavenumber ($\bar{\nu}$), then the visible lines of the hydrogen spectrum obey the following formula:

$$\bar{\nu} = 109,677 \left(\frac{1}{2^2} - \frac{1}{n^2} \right) \text{ cm}^{-1} \quad (2.8)$$

where n is an integer equal to or greater than 3 (i.e., $n = 3, 4, 5, \dots$)

The series of lines described by this formula are called the **Balmer series**. The Balmer series of lines are the only lines in the hydrogen spectrum which appear in the visible region of the electromagnetic spectrum. The Swedish spectroscopist, Johannes Rydberg, noted that all series of lines in the hydrogen spectrum could be described by the following expression :

$$\bar{\nu} = 109,677 \left(\frac{1}{n_1^2} - \frac{1}{n_2^2} \right) \text{ cm}^{-1} \quad (2.9)$$

where $n_1 = 1, 2, \dots$

$n_2 = n_1 + 1, n_1 + 2, \dots$

The value $109,677 \text{ cm}^{-1}$ is called the **Rydberg constant** for hydrogen. The first five series of lines that correspond to $n_1 = 1, 2, 3, 4, 5$ are known as Lyman, Balmer, Paschen, Brackett and Pfund series, respectively, Table 2.3 shows these series of transitions in the hydrogen spectrum. Fig. 2.11 (page, 46) shows the Lyman, Balmer and Paschen series of transitions for hydrogen atom.

Of all the elements, hydrogen atom has the simplest line spectrum. Line spectrum

Table 2.3 The Spectral Lines for Atomic Hydrogen

Series	n_1	n_2	Spectral Region
Lyman	1	2, 3, ...	Ultraviolet
Balmer	2	3, 4, ...	Visible
Paschen	3	4, 5, ...	Infrared
Brackett	4	5, 6, ...	Infrared
Pfund	5	6, 7, ...	Infrared

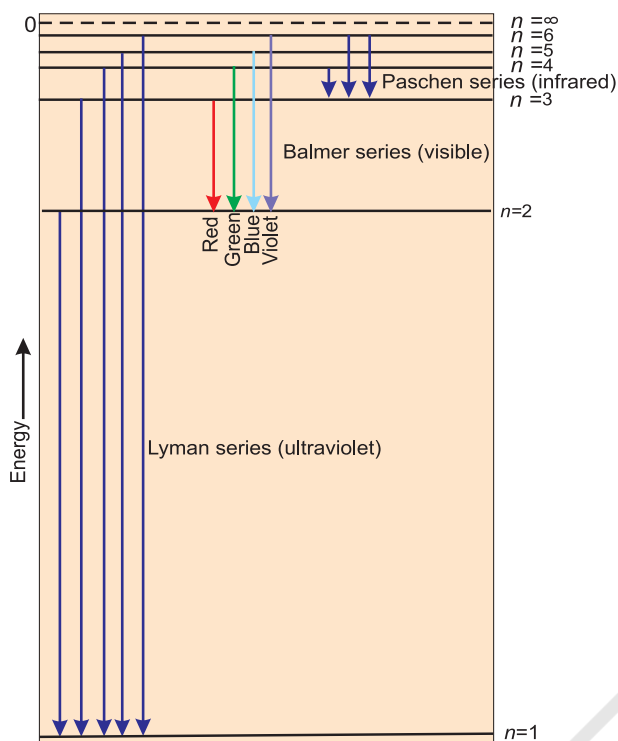

Fig. 2.11 Transitions of the electron in the hydrogen atom (The diagram shows the Lyman, Balmer and Paschen series of transitions)

becomes more and more complex for heavier atom. There are, however, certain features which are common to all line spectra, i.e., (i) line spectrum of element is unique and (ii) there is regularity in the line spectrum of each element. The questions which arise are: What are the reasons for these similarities? Is it something to do with the electronic structure of atoms? These are the questions need to be answered. We shall find later that the answers to these questions provide the key in understanding electronic structure of these elements.

2.4 BOHR'S MODEL FOR HYDROGEN ATOM

Neils Bohr (1913) was the first to explain quantitatively the general features of the structure of hydrogen atom and its spectrum. He used Planck's concept of quantisation of energy. Though the theory is not the modern quantum mechanics, it can still be used to rationalize many points in the

atomic structure and spectra. Bohr's model for hydrogen atom is based on the following postulates:

- i) The electron in the hydrogen atom can move around the nucleus in a circular path of fixed radius and energy. These paths are called **orbits**, stationary states or allowed energy states. These orbits are arranged concentrically around the nucleus.
- ii) The energy of an electron in the orbit does not change with time. However, the electron will move from a lower stationary state to a higher stationary state when required amount of energy is absorbed by the electron or energy is emitted when electron moves from higher stationary state to lower stationary state (equation 2.16). The energy change does not take place in a continuous manner.

Angular Momentum

Just as linear momentum is the product of mass (m) and linear velocity (v), angular momentum is the product of moment of inertia (I) and angular velocity (ω). For an electron of mass m_e , moving in a circular path of radius r around the nucleus,

$$\text{angular momentum} = I \times \omega$$

Since $I = m_e r^2$, and $\omega = v/r$ where v is the linear velocity,

$$\therefore \text{angular momentum} = m_e r^2 \times v/r = m_e v r$$

- iii) The frequency of radiation absorbed or emitted when transition occurs between two stationary states that differ in energy by ΔE , is given by:

$$n = \frac{\Delta E}{h} = \frac{E_2 - E_1}{h} \quad (2.10)$$

Where E_1 and E_2 are the energies of the lower and higher allowed energy states respectively. This expression is commonly known as Bohr's frequency rule.

- iv) The angular momentum of an electron is quantised. In a given stationary state it can be expressed as in equation (2.11)

$$m_e v r = n \cdot \frac{h}{2\pi} \quad n = 1, 2, 3, \dots \quad (2.11)$$

Where m_e is the mass of electron, v is the velocity and r is the radius of the orbit in which electron is moving.

Thus an electron can move only in those orbits for which its angular momentum is integral multiple of $h/2\pi$. That means angular momentum is quantised. Radiation is emitted or absorbed only when transition of electron takes place from one quantised value of angular momentum to another. Therefore, Maxwell's electromagnetic theory does not apply here that is why only certain fixed orbits are allowed.

The details regarding the derivation of energies of the stationary states used by Bohr, are quite complicated and will be discussed in higher classes. However, according to Bohr's theory for hydrogen atom:

- The stationary states for electron are numbered $n = 1, 2, 3, \dots$. These integral numbers (Section 2.6.2) are known as **Principal quantum numbers**.
- The radii of the stationary states are expressed as:

$$r_n = n^2 a_0 \quad (2.12)$$
 where $a_0 = 52.9$ pm. Thus the radius of the first stationary state, called the **Bohr orbit**, is 52.9 pm. Normally the electron in the hydrogen atom is found in this orbit (that is $n=1$). As n increases the value of r will increase. In other words the electron will be present away from the nucleus.
- The most important property associated with the electron, is the energy of its stationary state. It is given by the expression.

$$E_n = -R_H \left(\frac{1}{n^2} \right) \quad n = 1, 2, 3, \dots \quad (2.13)$$

where R_H is called **Rydberg constant** and its value is 2.18×10^{-18} J. The energy of the lowest state, also called as the ground state, is

$$E_1 = -2.18 \times 10^{-18} \left(\frac{1}{1^2} \right) = -2.18 \times 10^{-18} \text{ J.}$$

The energy of the stationary state for $n = 2$, will be : $E_2 = -2.18 \times 10^{-18} \text{ J} \left(\frac{1}{2^2} \right) = -0.545 \times 10^{-18} \text{ J.}$



Niels Bohr
(1885–1962)

Niels Bohr, a Danish physicist received his Ph.D. from the University of Copenhagen in 1911. He then spent a year with J.J. Thomson and Ernest Rutherford in England. In 1913, he returned to Copenhagen where he remained for the rest of his life. In 1920 he was named Director of the Institute of theoretical Physics. After first World War, Bohr worked energetically for peaceful uses of atomic energy. He received the first Atoms for Peace award in 1957. Bohr was awarded the Nobel Prize in Physics in 1922.

Fig. 2.11 depicts the energies of different stationary states or energy levels of hydrogen atom. This representation is called an energy level diagram.

When the electron is free from the influence of nucleus, the energy is taken as zero. The electron in this situation is associated with the stationary state of Principal Quantum number = $n = \infty$ and is called as ionized hydrogen atom. When the electron is attracted by the nucleus and is present in orbit n , the energy is emitted and its energy is lowered. That is the reason

What does the negative electronic energy (E_n) for hydrogen atom mean?

The energy of the electron in a hydrogen atom has a negative sign for all possible orbits (eq. 2.13). What does this negative sign convey? This negative sign means that the energy of the electron in the atom is lower than the energy of a free electron at rest. A free electron at rest is an electron that is infinitely far away from the nucleus and is assigned the energy value of zero. Mathematically, this corresponds to setting n equal to infinity in the equation (2.13) so that $E_\infty = 0$. As the electron gets closer to the nucleus (as n decreases), E_n becomes larger in absolute value and more and more negative. The most negative energy value is given by $n=1$ which corresponds to the most stable orbit. We call this the ground state.

for the presence of negative sign in equation (2.13) and depicts its stability relative to the reference state of zero energy and $n = \infty$.

d) Bohr's theory can also be applied to the ions containing only one electron, similar to that present in hydrogen atom. For example, He^+ , Li^{2+} , Be^{3+} and so on. The energies of the stationary states associated with these kinds of ions (also known as hydrogen like species) are given by the expression.

$$E_n = -2.18 \times 10^{-18} \left(\frac{Z^2}{n^2} \right) \text{J} \quad (2.14)$$

and radii by the expression

$$r_n = \frac{52.9(n^2)}{Z} \text{pm} \quad (2.15)$$

where Z is the atomic number and has values 2,3 for the helium and lithium atoms respectively. From the above equations, it is evident that the value of energy becomes more negative and that of radius becomes smaller with increase of Z . This means that electron will be tightly bound to the nucleus.

e) It is also possible to calculate the velocities of electrons moving in these orbits. Although the precise equation is not given here, qualitatively the magnitude of velocity of electron increases with increase of positive charge on the nucleus and decreases with increase of principal quantum number.

2.4.1 Explanation of Line Spectrum of Hydrogen

Line spectrum observed in case of hydrogen atom, as mentioned in section 2.3.3, can be explained quantitatively using Bohr's model. According to assumption 2, radiation (energy) is absorbed if the electron moves from the orbit of smaller Principal quantum number to the orbit of higher Principal quantum number, whereas the radiation (energy) is emitted if the electron moves from higher orbit to lower orbit. The energy gap between the two orbits is given by equation (2.16)

$$\Delta E = E_f - E_i \quad (2.16)$$

Combining equations (2.13) and (2.16)

$$\Delta E = \left(-\frac{R_H}{n_f^2} \right) - \left(-\frac{R_H}{n_i^2} \right) \quad (\text{where } n_i \text{ and } n_f$$

stand for initial orbit and final orbits)

$$\Delta E = R_H \left(\frac{1}{n_i^2} - \frac{1}{n_f^2} \right) = 2.18 \times 10^{-18} \text{J} \left(\frac{1}{n_i^2} - \frac{1}{n_f^2} \right) \quad (2.17)$$

The frequency (ν) associated with the absorption and emission of the photon can be evaluated by using equation (2.18)

$$\begin{aligned} \nu &= \frac{\Delta E}{h} = \frac{R_H}{h} \left(\frac{1}{n_i^2} - \frac{1}{n_f^2} \right) \\ &= \frac{2.18 \times 10^{-18} \text{J}}{6.626 \times 10^{-34} \text{Js}} \left(\frac{1}{n_i^2} - \frac{1}{n_f^2} \right) \end{aligned} \quad (2.18)$$

$$= 3.29 \times 10^{15} \left(\frac{1}{n_i^2} - \frac{1}{n_f^2} \right) \text{Hz} \quad (2.19)$$

and in terms of wavenumbers ($\bar{\nu}$)

$$\begin{aligned} \bar{\nu} &= \frac{\nu}{c} = \frac{R_H}{hc} \left(\frac{1}{n_i^2} - \frac{1}{n_f^2} \right) \\ &= \frac{3.29 \times 10^{15} \text{s}^{-1}}{3 \times 10^8 \text{ms}^{-1}} \left(\frac{1}{n_i^2} - \frac{1}{n_f^2} \right) \\ &= 1.09677 \times 10^7 \left(\frac{1}{n_i^2} - \frac{1}{n_f^2} \right) \text{m}^{-1} \end{aligned} \quad (2.21)$$

In case of absorption spectrum, $n_f > n_i$ and the term in the parenthesis is positive and energy is absorbed. On the other hand in case of emission spectrum $n_i > n_f$, ΔE is negative and energy is released.

The expression (2.17) is similar to that used by Rydberg (2.9) derived empirically using the experimental data available at that time. Further, each spectral line, whether in absorption or emission spectrum, can be associated to the particular transition in hydrogen atom. In case of large number of hydrogen atoms, different possible transitions can be observed and thus leading to large number of spectral lines. The brightness or intensity of spectral lines depends upon the number of photons of same wavelength or frequency absorbed or emitted.

Problem 2.10

What are the frequency and wavelength of a photon emitted during a transition from $n = 5$ state to the $n = 2$ state in the hydrogen atom?

Solution

Since $n_i = 5$ and $n_f = 2$, this transition gives rise to a spectral line in the visible region of the Balmer series. From equation (2.17)

$$\begin{aligned}\Delta E &= 2.18 \times 10^{-18} \text{ J} \left[\frac{1}{5^2} - \frac{1}{2^2} \right] \\ &= -4.58 \times 10^{-19} \text{ J}\end{aligned}$$

It is an emission energy

The frequency of the photon (taking energy in terms of magnitude) is given by

$$\begin{aligned}\nu &= \frac{\Delta E}{h} \\ &= \frac{4.58 \times 10^{-19} \text{ J}}{6.626 \times 10^{-34} \text{ J s}} \\ &= 6.91 \times 10^{14} \text{ Hz} \\ \lambda &= \frac{c}{\nu} = \frac{3.0 \times 10^8 \text{ m s}^{-1}}{6.91 \times 10^{14} \text{ Hz}} = 434 \text{ nm}\end{aligned}$$

Problem 2.11

Calculate the energy associated with the first orbit of He^+ . What is the radius of this orbit?

Solution

$$E_n = -\frac{(2.18 \times 10^{-18} \text{ J})Z^2}{n^2} \text{ atom}^{-1}$$

For He^+ , $n = 1$, $Z = 2$

$$E_1 = -\frac{(2.18 \times 10^{-18} \text{ J})(2^2)}{1^2} = -8.72 \times 10^{-18} \text{ J}$$

The radius of the orbit is given by equation (2.15)

$$r_n = \frac{(0.0529 \text{ nm})n^2}{Z}$$

Since $n = 1$, and $Z = 2$

$$r_n = \frac{(0.0529 \text{ nm})1^2}{2} = 0.02645 \text{ nm}$$

2.4.2 Limitations of Bohr's Model

Bohr's model of the hydrogen atom was no doubt an improvement over Rutherford's nuclear model, as it could account for the stability and line spectra of hydrogen atom and hydrogen like ions (for example, He^+ , Li^{2+} , Be^{3+} , and so on). However, Bohr's model was too simple to account for the following points.

- It fails to account for the finer details (doublet, that is two closely spaced lines) of the hydrogen atom spectrum observed by using sophisticated spectroscopic techniques. This model is also unable to explain the spectrum of atoms other than hydrogen, for example, helium atom which possesses only two electrons. Further, Bohr's theory was also unable to explain the splitting of spectral lines in the presence of magnetic field (Zeeman effect) or an electric field (Stark effect).
- It could not explain the ability of atoms to form molecules by chemical bonds.

In other words, taking into account the points mentioned above, one needs a better theory which can explain the salient features of the structure of complex atoms.

2.5 TOWARDS QUANTUM MECHANICAL MODEL OF THE ATOM

In view of the shortcoming of the Bohr's model, attempts were made to develop a more suitable and general model for atoms. Two important developments which contributed significantly in the formulation of such a model were:

- Dual behaviour of matter,
- Heisenberg uncertainty principle.

2.5.1 Dual Behaviour of Matter

The French physicist, de Broglie, in 1924 proposed that matter, like radiation, should also exhibit dual behaviour i.e., both particle and wavelike properties. This means that just as the photon has momentum as well as wavelength, electrons should also have momentum as well as wavelength, de Broglie, from this analogy, gave the following relation between wavelength (λ) and momentum (p) of a material particle.

**Louis de Broglie
(1892–1987)**

Louis de Broglie, a French physicist, studied history as an undergraduate in the early 1910's. His interest turned to science as a result of his assignment to radio communications in World War I. He received his Dr. Sc. from the University of Paris in 1924. He was professor of theoretical physics at the University of Paris from 1932 until his retirement in 1962. He was awarded the Nobel Prize in Physics in 1929.



$$\lambda = \frac{h}{mv} = \frac{h}{p} \quad (2.22)$$

where m is the mass of the particle, v its velocity and p its momentum. de Broglie's prediction was confirmed experimentally when it was found that an electron beam undergoes diffraction, a phenomenon characteristic of waves. This fact has been put to use in making an electron microscope, which is based on the wavelike behaviour of electrons just as an ordinary microscope utilises the wave nature of light. An electron microscope is a powerful tool in modern scientific research because it achieves a magnification of about 15 million times.

It needs to be noted that according to de Broglie, every object in motion has a wave character. The wavelengths associated with ordinary objects are so short (because of their large masses) that their wave properties cannot be detected. The wavelengths associated with electrons and other subatomic particles (with very small mass) can however be detected experimentally. Results obtained from the following problems prove these points qualitatively.

Problem 2.12

What will be the wavelength of a ball of mass 0.1 kg moving with a velocity of 10 m s⁻¹?

Solution

According to de Broglie equation (2.22)

$$\begin{aligned} \lambda &= \frac{h}{mv} = \frac{(6.626 \times 10^{-34} \text{ Js})}{(0.1 \text{ kg})(10 \text{ m s}^{-1})} \\ &= 6.626 \times 10^{-34} \text{ m} \quad (\text{J} = \text{kg m}^2 \text{ s}^{-2}) \end{aligned}$$

Problem 2.13

The mass of an electron is 9.1×10^{-31} kg. If its K.E. is 3.0×10^{-25} J, calculate its wavelength.

Solution

Since K.E. = $\frac{1}{2} mv^2$

$$\begin{aligned} v &= \left(\frac{2\text{K.E.}}{m} \right)^{1/2} = \left(\frac{2 \times 3.0 \times 10^{-25} \text{ kg m}^2 \text{ s}^{-2}}{9.1 \times 10^{-31} \text{ kg}} \right)^{1/2} \\ &= 812 \text{ m s}^{-1} \end{aligned}$$

$$\begin{aligned} \lambda &= \frac{h}{mv} = \frac{6.626 \times 10^{-34} \text{ Js}}{(9.1 \times 10^{-31} \text{ kg})(812 \text{ m s}^{-1})} \\ &= 8967 \times 10^{-10} \text{ m} = 896.7 \text{ nm} \end{aligned}$$

Problem 2.14

Calculate the mass of a photon with wavelength 3.6 Å.

Solution

$$\lambda = 3.6 \text{ \AA} = 3.6 \times 10^{-10} \text{ m}$$

Velocity of photon = velocity of light

$$\begin{aligned} m &= \frac{h}{\lambda v} = \frac{6.626 \times 10^{-34} \text{ Js}}{(3.6 \times 10^{-10} \text{ m})(3 \times 10^8 \text{ m s}^{-1})} \\ &= 6.135 \times 10^{-29} \text{ kg} \end{aligned}$$

2.5.2 Heisenberg's Uncertainty Principle

Werner Heisenberg a German physicist in 1927, stated uncertainty principle which is the consequence of dual behaviour of matter and radiation. **It states that it is impossible to determine simultaneously, the exact position and exact momentum (or velocity) of an electron.**

Mathematically, it can be given as in equation (2.23).

$$\Delta x \times \Delta p_x \geq \frac{h}{4\pi} \quad (2.23)$$

$$\text{or } \Delta x \times \Delta(mv_x) \geq \frac{h}{4\pi}$$

$$\text{or } \Delta x \times \Delta v_x \geq \frac{h}{4\pi m}$$

where Δx is the uncertainty in position and Δp_x (or Δv_x) is the uncertainty in momentum (or velocity) of the particle. If the position of the electron is known with high degree of accuracy (Δx is small), then the velocity of the electron will be uncertain [$\Delta(v_x)$ is large]. On the other hand, if the velocity of the electron is known precisely ($\Delta(v_x)$ is small), then the position of the electron will be uncertain (Δx will be large). Thus, if we carry out some physical measurements on the electron's position or velocity, the outcome will always depict a fuzzy or blur picture.

The uncertainty principle can be best understood with the help of an example. Suppose you are asked to measure the thickness of a sheet of paper with an unmarked metrestick. Obviously, the results obtained would be extremely inaccurate and meaningless. In order to obtain any accuracy, you should use an instrument graduated in units smaller than the thickness of a sheet of the paper. Analogously, in order to determine the position of an electron, we must use a meterstick calibrated in units of smaller than the dimensions of electron (keep in mind that an electron is considered as a point charge and is therefore, dimensionless). To observe an electron, we can illuminate it with "light" or electromagnetic radiation. The "light" used must have a wavelength smaller than the dimensions of an electron. The high

momentum photons of such light $\left(p = \frac{h}{\lambda}\right)$

would change the energy of electrons by collisions. In this process we, no doubt, would be able to calculate the position of the electron, but we would know very little about the velocity of the electron after the collision.

Significance of Uncertainty Principle

One of the important implications of the Heisenberg Uncertainty Principle is that **it rules out existence of definite paths or trajectories of electrons and other similar particles.** The trajectory of an object is determined by its location and velocity at various moments. If we know where a body is at a particular instant and if we also know its velocity and the forces acting on it at that instant, we can tell where the body would be sometime later. We, therefore, conclude that the position of an object and its velocity fix its trajectory. Since for a sub-atomic object such as an electron, it is not possible simultaneously to determine the position and velocity at any given instant to an arbitrary degree of precision, it is not possible to talk of the trajectory of an electron.

The effect of Heisenberg Uncertainty Principle is significant only for motion of microscopic objects and is negligible for that of macroscopic objects. This can be seen from the following examples.

If uncertainty principle is applied to an object of mass, say about a milligram (10^{-6} kg), then

$$\begin{aligned} \Delta v \cdot \Delta x &= \frac{h}{4\pi m} \\ &= \frac{6.626 \times 10^{-34} \text{ J s}}{4 \times 3.1416 \times 10^{-6} \text{ kg}} \approx 10^{-28} \text{ m}^2 \text{ s}^{-1} \end{aligned}$$

Werner Heisenberg (1901–1976) Werner Heisenberg (1901–1976) received his Ph.D. in physics from the University of Munich in 1923. He then spent a year working with Max Born at Göttingen and three years with Niels Bohr in Copenhagen. He was professor of physics at the University of Leipzig from 1927 to 1941. During World War II, Heisenberg was in charge of German research on the atomic bomb. After the war he was named director of Max Planck Institute for physics in Göttingen. He was also accomplished mountain climber. Heisenberg was awarded the Nobel Prize in Physics in 1932.



The value of $\Delta v \Delta x$ obtained is extremely small and is insignificant. Therefore, one may say that **in dealing with milligram-sized or heavier objects, the associated uncertainties are hardly of any real consequence.**

In the case of a microscopic object like an electron on the other hand, $\Delta v \Delta x$ obtained is much larger and such uncertainties are of real consequence. For example, for an electron whose mass is 9.11×10^{-31} kg., according to Heisenberg uncertainty principle

$$\begin{aligned}\Delta v \Delta x &= \frac{h}{4\pi m} \\ &= \frac{6.626 \times 10^{-34} \text{ Js}}{4 \times 3.1416 \times 9.11 \times 10^{-31} \text{ kg}} \\ &= 10^{-4} \text{ m}^2 \text{ s}^{-1}\end{aligned}$$

It, therefore, means that if one tries to find the exact location of the electron, say to an uncertainty of only 10^{-8} m, then the uncertainty Δv in velocity would be

$$\frac{10^{-4} \text{ m}^2 \text{ s}^{-1}}{10^{-8} \text{ m}} \approx 10^4 \text{ m s}^{-1}$$

which is so large that the classical picture of electrons moving in Bohr's orbits (fixed) cannot hold good. **It, therefore, means that the precise statements of the position and momentum of electrons have to be replaced by the statements of probability, that the electron has at a given position and momentum. This is what happens in the quantum mechanical model of atom.**

Problem 2.15

A microscope using suitable photons is employed to locate an electron in an atom within a distance of 0.1 \AA . What is the uncertainty involved in the measurement of its velocity?

Solution

$$\Delta x \Delta p = \frac{h}{4\pi} \text{ or } \Delta x m \Delta v = \frac{h}{4\pi}$$

$$\Delta v = \frac{h}{4\pi \Delta x m}$$

$$\begin{aligned}\Delta v &= \frac{6.626 \times 10^{-34} \text{ Js}}{4 \times 3.14 \times 0.1 \times 10^{-10} \text{ m} \times 9.11 \times 10^{-31} \text{ kg}} \\ &= 0.579 \times 10^7 \text{ m s}^{-1} \quad (1 \text{ J} = 1 \text{ kg m}^2 \text{ s}^{-2}) \\ &= 5.79 \times 10^6 \text{ m s}^{-1}\end{aligned}$$

Problem 2.16

A golf ball has a mass of 40g, and a speed of 45 m/s. If the speed can be measured within accuracy of 2%, calculate the uncertainty in the position.

Solution

The uncertainty in the speed is 2%, i.e.,

$$45 \times \frac{2}{100} = 0.9 \text{ m s}^{-1}$$

Using the equation (2.22)

$$\begin{aligned}\Delta x &= \frac{h}{4\pi m \Delta v} \\ &= \frac{6.626 \times 10^{-34} \text{ Js}}{4 \times 3.14 \times 40 \text{ g} \times 10^{-3} \text{ kg g}^{-1} (0.9 \text{ m s}^{-1})} \\ &= 1.46 \times 10^{-33} \text{ m}\end{aligned}$$

This is nearly $\sim 10^{18}$ times smaller than the diameter of a typical atomic nucleus. As mentioned earlier for large particles, the uncertainty principle sets no meaningful limit to the precision of measurements.

Reasons for the Failure of the Bohr Model

One can now understand the reasons for the failure of the Bohr model. In Bohr model, an electron is regarded as a charged particle moving in well defined circular orbits about the nucleus. The wave character of the electron is not considered in Bohr model. Further, an orbit is a clearly defined path and this path can completely be defined only if both the position and the velocity of the electron are known exactly at the same time. This is not possible according to the Heisenberg uncertainty principle. *Bohr model of the hydrogen atom, therefore, not only ignores dual behaviour of matter but also contradicts Heisenberg uncertainty principle.*

Erwin Schrödinger, an Austrian physicist received his Ph.D. in theoretical physics from the University of Vienna in 1910. In 1927 Schrödinger succeeded Max Planck at the University of Berlin at Planck's request. In 1933, Schrödinger left Berlin because of his opposition to Hitler and Nazi policies and returned to Austria in 1936. After the invasion of Austria by Germany, Schrödinger was forcibly removed from his professorship. He then moved to Dublin, Ireland where he remained for seventeen years. Schrödinger shared the Nobel Prize for Physics with P.A.M. Dirac in 1933.



Erwin Schrödinger
(1887–1961)

In view of these inherent weaknesses in the Bohr model, there was no point in extending Bohr model to other atoms. In fact an insight into the structure of the atom was needed which could account for wave-particle duality of matter and be consistent with Heisenberg uncertainty principle. This came with the advent of quantum mechanics.

2.6 QUANTUM MECHANICAL MODEL OF ATOM

Classical mechanics, based on Newton's laws of motion, successfully describes the motion of all macroscopic objects such as a falling stone, orbiting planets etc., which have essentially a particle-like behaviour as shown in the previous section. However it fails when applied to microscopic objects like electrons, atoms, molecules etc. This is mainly because of the fact that classical mechanics ignores the concept of dual behaviour of matter especially for sub-atomic particles and the uncertainty principle. The branch of science that takes into account this dual behaviour of matter is called **quantum mechanics**.

Quantum mechanics is a theoretical science that deals with the study of the motions of the microscopic objects that have both observable wave like and particle like properties. It specifies the laws of motion that

these objects obey. When quantum mechanics is applied to macroscopic objects (for which wave like properties are insignificant) the results are the same as those from the classical mechanics.

Quantum mechanics was developed independently in 1926 by Werner Heisenberg and Erwin Schrödinger. Here, however, we shall be discussing the quantum mechanics which is based on the ideas of wave motion. The fundamental equation of quantum mechanics was developed by Schrödinger and it won him the Nobel Prize in Physics in 1933. This equation which incorporates wave-particle duality of matter as proposed by de Broglie is quite complex and knowledge of higher mathematics is needed to solve it. You will learn its solutions for different systems in higher classes.

For a system (such as an atom or a molecule whose energy does not change with time) the **Schrödinger equation** is written as $\hat{H}\Psi = E\Psi$ where \hat{H} is a mathematical operator called Hamiltonian. Schrödinger gave a recipe of constructing this operator from the expression for the total energy of the system. The total energy of the system takes into account the kinetic energies of all the sub-atomic particles (electrons, nuclei), attractive potential between the electrons and nuclei and repulsive potential among the electrons and nuclei individually. Solution of this equation gives E and ψ .

Hydrogen Atom and the Schrödinger Equation

When Schrödinger equation is solved for hydrogen atom, the solution gives the possible energy levels the electron can occupy and the corresponding wave function(s) (ψ) of the electron associated with each energy level. These quantized energy states and corresponding wave functions which are characterized by a set of three quantum numbers (**principal quantum number n , azimuthal quantum number l and magnetic quantum number m_l**) arise as a natural consequence in the solution of the Schrödinger equation. When an electron is in any energy state, the wave function

corresponding to that energy state contains all information about the electron. The wave function is a mathematical function whose value depends upon the coordinates of the electron in the atom and does not carry any physical meaning. Such wave functions of hydrogen or hydrogen like species with one electron are called **atomic orbitals**. Such wave functions pertaining to one-electron species are called one-electron systems. The probability of finding an electron at a point within an atom is proportional to the $|\psi|^2$ at that point. The quantum mechanical results of the hydrogen atom successfully predict all aspects of the hydrogen atom spectrum including some phenomena that could not be explained by the Bohr model.

Application of Schrödinger equation to multi-electron atoms presents a difficulty: the Schrödinger equation cannot be solved exactly for a multi-electron atom. This difficulty can be overcome by using approximate methods. Such calculations with the aid of modern computers show that orbitals in atoms other than hydrogen do not differ in any radical way from the hydrogen orbitals discussed above. The principal difference lies in the consequence of increased nuclear charge. Because of this all the orbitals are somewhat contracted. Further, as you shall see later (in subsections 2.6.3 and 2.6.4), unlike orbitals of hydrogen or hydrogen like species, whose energies depend only on the quantum number n , the energies of the orbitals in multi-electron atoms depend on quantum numbers n and l .

Important Features of the Quantum Mechanical Model of Atom

Quantum mechanical model of atom is the picture of the structure of the atom, which emerges from the application of the Schrödinger equation to atoms. The following are the important features of the quantum-mechanical model of atom:

1. The energy of electrons in atoms is quantized (i.e., can only have certain specific values), for example when electrons are bound to the nucleus in atoms.

2. The existence of quantised electronic energy levels is a direct result of the wave like properties of electrons and are allowed solutions of Schrödinger wave equation.
3. Both the exact position and exact velocity of an electron in an atom cannot be determined simultaneously (Heisenberg uncertainty principle). The path of an electron in an atom therefore, can never be determined or known accurately. That is why, as you shall see later on, one talks of only probability of finding the electron at different points in an atom.
4. **An atomic orbital is the wave function ψ for an electron in an atom.** Whenever an electron is described by a wave function, we say that the electron occupies that orbital. Since many such wave functions are possible for an electron, there are many atomic orbitals in an atom. These “one electron orbital wave functions” or orbitals form the basis of the electronic structure of atoms. In each orbital, the electron has a definite energy. An orbital cannot contain more than two electrons. In a multi-electron atom, the electrons are filled in various orbitals in the order of increasing energy. For each electron of a multi-electron atom, there shall, therefore, be an orbital wave function characteristic of the orbital it occupies. All the information about the electron in an atom is stored in its orbital wave function ψ and quantum mechanics makes it possible to extract this information out of ψ .
5. The probability of finding an electron at a point within an atom is proportional to the square of the orbital wave function i.e., $|\psi|^2$ at that point. $|\psi|^2$ is known as **probability density** and is always positive. **From the value of $|\psi|^2$ at different points within an atom, it is possible to predict the region around the nucleus where electron will most probably be found.**

2.6.1 Orbitals and Quantum Numbers

A large number of orbitals are possible in an atom. Qualitatively these orbitals can

be distinguished by their size, shape and orientation. An orbital of smaller size means there is more chance of finding the electron near the nucleus. Similarly shape and orientation mean that there is more probability of finding the electron along certain directions than along others. Atomic orbitals are precisely distinguished by what are known as quantum numbers. Each orbital is designated by three quantum numbers labelled as n , l and m_l .

The principal quantum number 'n' is a positive integer with value of $n = 1, 2, 3, \dots$. The principal quantum number determines the *size and to large extent the energy of the orbital*. For hydrogen atom and hydrogen like species (He^+ , Li^{2+} , etc.) energy and size of the orbital depends only on 'n'.

The principal quantum number also identifies the **shell**. With the increase in the value of 'n', the number of allowed orbital increases and **are given by 'n²'** All the orbitals of a given value of 'n' constitute a **single shell of atom** and are represented by the following letters

$$n = 1 \quad 2 \quad 3 \quad 4 \quad \dots\dots\dots$$

$$\text{Shell} = \text{K L M N } \dots\dots\dots$$

Size of an orbital increases with increase of principal quantum number 'n'. In other words the electron will be located away from the nucleus. Since energy is required in shifting away the negatively charged electron from the positively charged nucleus, the energy of the orbital will increase with increase of n .

Azimuthal quantum number. 'l' is also known as **orbital angular momentum or subsidiary quantum number**. It defines the three-dimensional shape of the orbital. For a given value of n , l can have n values ranging from 0 to $n - 1$, that is, for a given value of n , the possible value of l are : $l = 0, 1, 2, \dots\dots\dots (n-1)$

For example, when $n = 1$, value of l is only 0. For $n = 2$, the possible value of l can be 0 and 1. For $n = 3$, the possible l values are 0, 1 and 2.

Each shell consists of one or more **sub-shells** or **sub-levels**. The number of

sub-shells in a principal shell is equal to the value of n . For example in the first shell ($n = 1$), there is only one sub-shell which corresponds to $l = 0$. There are two sub-shells ($l = 0, 1$) in the second shell ($n = 2$), three ($l = 0, 1, 2$) in third shell ($n = 3$) and so on. Each sub-shell is assigned an azimuthal quantum number (l). Sub-shells corresponding to different values of l are represented by the following symbols. Value for l : 0 1 2 3 4 5 notation for s p d f g h sub-shell

Table 2.4 shows the permissible values of 'l' for a given principal quantum number and the corresponding sub-shell notation.

Table 2.4 Subshell Notations

n	l	Subshell notation
1	0	1s
2	0	2s
2	1	2p
3	0	3s
3	1	3p
3	2	3d
4	0	4s
4	1	4p
4	2	4d
4	3	4f

Magnetic orbital quantum number. 'm_l' gives information about the **spatial orientation of the orbital with respect to standard set of co-ordinate axis**. For any **sub-shell (defined by 'l' value)** $2l+1$ values of m_l are possible and these values are given by : $m_l = -l, -(l-1), -(l-2) \dots 0, 1 \dots (l-2), (l-1), l$

Thus for $l = 0$, the only permitted value of $m_l = 0$, [$2(0)+1 = 1$, one s orbital]. For $l = 1$, m_l can be $-1, 0$ and $+1$ [$2(1)+1 = 3$, three p orbitals]. For $l = 2$, $m_l = -2, -1, 0, +1$ and $+2$, [$2(2)+1 = 5$, five d orbitals]. It should be noted that the values of m_l are derived from l and that the value of l are derived from n .

Each orbital in an atom, therefore, is defined by a set of values for n , l and m_l . An orbital described by the quantum numbers $n = 2$, $l = 1$, $m_l = 0$ is an orbital in the p subshell of the second shell. The following chart gives the relation between the subshell and the number of orbitals associated with it.

Value of l	0	1	2	3	4	5
Subshell notation	s	p	d	f	g	h
number of orbitals	1	3	5	7	9	11

Electron spin 's' : The three quantum numbers labelling an atomic orbital can be used equally well to define its energy, shape and orientation. But all these quantum numbers are not enough to explain the line spectra observed in the case of multi-electron atoms, that is, some of the lines actually occur in doublets (two lines closely spaced), triplets (three lines, closely spaced) etc. This suggests the presence of a few more energy levels than predicted by the three quantum numbers.

In 1925, George Uhlenbeck and Samuel Goudsmit proposed the presence of the fourth quantum number known as the **electron spin quantum number (m_s)**. An electron spins around its own axis, much in a similar way as earth spins around its own axis while revolving around the sun. In other words, an electron has, besides charge and mass, intrinsic spin angular quantum number. Spin

angular momentum of the electron — a vector quantity, can have two orientations relative to the chosen axis. These two orientations are distinguished by the spin quantum numbers m_s which can take the values of $+\frac{1}{2}$ or $-\frac{1}{2}$. These are called the **two spin states of the electron** and are normally represented by two arrows, \uparrow (spin up) and \downarrow (spin down). Two electrons that have different m_s values (one $+\frac{1}{2}$ and the other $-\frac{1}{2}$) are said to have opposite spins. An orbital cannot hold more than two electrons and these two electrons should have opposite spins.

To sum up, the four quantum numbers provide the following information :

- n defines the shell, determines the size of the orbital and also to a large extent the energy of the orbital.
- There are n subshells in the n^{th} shell. l identifies the subshell and determines the shape of the orbital (see section 2.6.2). There are $(2l+1)$ orbitals of each type in a subshell, that is, one s orbital ($l = 0$), three p orbitals ($l = 1$) and five d orbitals ($l = 2$) per subshell. To some extent l also determines the energy of the orbital in a multi-electron atom.
- m_l designates the orientation of the orbital. For a given value of l , m_l has $(2l+1)$ values, the same as the number of orbitals per subshell. It means that

Orbit, orbital and its importance

Orbit and orbital are not synonymous. An orbit, as proposed by Bohr, is a circular path around the nucleus in which an electron moves. A precise description of this path of the electron is impossible according to Heisenberg uncertainty principle. Bohr orbits, therefore, have no real meaning and their existence can never be demonstrated experimentally. An atomic orbital, on the other hand, is a quantum mechanical concept and refers to the one electron wave function ψ in an atom. It is characterized by three quantum numbers (n , l and m_l) and its value depends upon the coordinates of the electron. ψ has, by itself, no physical meaning. It is the square of the wave function i.e., $|\psi|^2$ which has a physical meaning. $|\psi|^2$ at any point in an atom gives the value of probability density at that point. Probability density ($|\psi|^2$) is the probability per unit volume and the product of $|\psi|^2$ and a small volume (called a volume element) yields the probability of finding the electron in that volume (the reason for specifying a small volume element is that $|\psi|^2$ varies from one region to another in space but its value can be assumed to be constant within a small volume element). The total probability of finding the electron in a given volume can then be calculated by the sum of all the products of $|\psi|^2$ and the corresponding volume elements. It is thus possible to get the probable distribution of an electron in an orbital.

the number of orbitals is equal to the number of ways in which they are oriented.

- iv) m_s refers to orientation of the spin of the electron.

Problem 2.17

What is the total number of orbitals associated with the principal quantum number $n = 3$?

Solution

For $n = 3$, the possible values of l are 0, 1 and 2. Thus there is one 3s orbital ($n = 3, l = 0$ and $m_l = 0$); there are three 3p orbitals ($n = 3, l = 1$ and $m_l = -1, 0, +1$); there are five 3d orbitals ($n = 3, l = 2$ and $m_l = -2, -1, 0, +1, +2$).

Therefore, the total number of orbitals is $1+3+5 = 9$

The same value can also be obtained by using the relation; number of orbitals = n^2 , i.e. $3^2 = 9$.

Problem 2.18

Using s, p, d, f notations, describe the orbital with the following quantum numbers

- (a) $n = 2, l = 1$, (b) $n = 4, l = 0$, (c) $n = 5, l = 3$, (d) $n = 3, l = 2$

Solution

	n	l	orbital
a)	2	1	2p
b)	4	0	4s
c)	5	3	5f
d)	3	2	3d

2.6.2 Shapes of Atomic Orbitals

The orbital wave function or ψ for an electron in an atom has no physical meaning. It is simply a mathematical function of the coordinates of the electron. However, for different orbitals the plots of corresponding wave functions as a function of r (the distance from the nucleus) are different. Fig. 2.12(a), gives such plots for 1s ($n = 1, l = 0$) and 2s ($n = 2, l = 0$) orbitals.

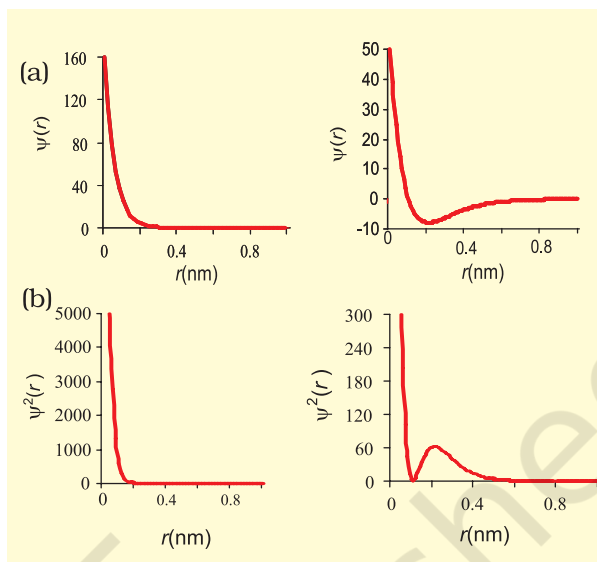

Fig. 2.12 The plots of (a) the orbital wave function $\psi(r)$; (b) the variation of probability density $\psi^2(r)$ as a function of distance r of the electron from the nucleus for 1s and 2s orbitals.

According to the German physicist, Max Born, the square of the wave function (i.e., ψ^2) at a point gives the probability density of the electron at that point. The variation of ψ^2 as a function of r for 1s and 2s orbitals is given in Fig. 2.12(b). Here again, you may note that the curves for 1s and 2s orbitals are different.

It may be noted that for 1s orbital the probability density is maximum at the nucleus and it decreases sharply as we move away from it. On the other hand, for 2s orbital the probability density first decreases sharply to zero and again starts increasing. After reaching a small maxima it decreases again and approaches zero as the value of r increases further. The region where this probability density function reduces to zero is called **nodal surfaces** or simply **nodes**. In general, it has been found that ns -orbital has $(n - 1)$ nodes, that is, number of nodes increases with increase of principal quantum number n . In other words, number of nodes for 2s orbital is one, two for 3s and so on.

These probability density variation can be visualised in terms of charge cloud diagrams [Fig. 2.13(a)]. In these diagrams, the density

of the dots in a region represents electron probability density in that region.

Boundary surface diagrams of constant probability density for different orbitals give a fairly good representation of the shapes of the orbitals. In this representation, a boundary surface or contour surface is drawn in space for an orbital on which the value of probability density $|\psi|^2$ is constant. In principle many such boundary surfaces may be possible. However, for a given orbital, only that boundary surface diagram of constant probability density* is taken to be good representation of the shape of the orbital which encloses a region or volume in which the probability of finding the electron is very high, say, 90%. The boundary surface diagram for 1s and 2s orbitals are given in Fig. 2.13(b). One may ask a question : Why do we not draw a boundary surface diagram, which bounds a region in which the probability of finding the electron is, 100 %? The answer to this question is that the probability density $|\psi|^2$ has always some value, however small it may be, at any finite distance from the nucleus. It is therefore, not possible to draw a boundary surface diagram of a rigid size in which the probability of finding the electron is 100%. Boundary surface diagram for a s orbital is actually a sphere centred on the nucleus. In two dimensions, this sphere looks like a circle. It encloses a region in which probability of finding the electron is about 90%.

Thus, we see that 1s and 2s orbitals are spherical in shape. In reality all the s-orbitals are spherically symmetric, that is, the probability of finding the electron at a given distance is equal in all the directions. It is also observed that the size of the s orbital increases with increase in n , that is, $4s > 3s > 2s > 1s$ and the electron is located further away from the nucleus as the principal quantum number increases.

Boundary surface diagrams for three 2p orbitals ($l = 1$) are shown in Fig. 2.14. In

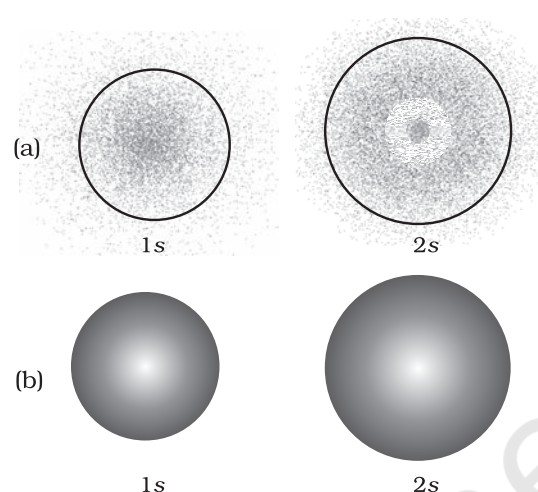

Fig. 2.13 (a) Probability density plots of 1s and 2s atomic orbitals. The density of the dots represents the probability density of finding the electron in that region. (b) Boundary surface diagram for 1s and 2s orbitals.

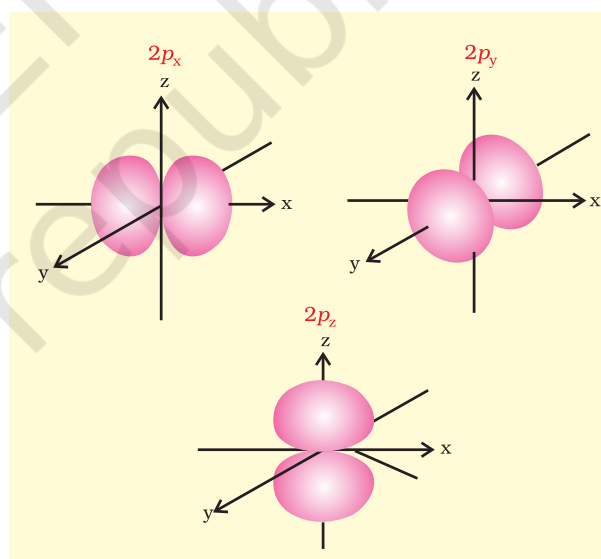

Fig. 2.14 Boundary surface diagrams of the three 2p orbitals.

these diagrams, the nucleus is at the origin. Here, unlike s-orbitals, the boundary surface diagrams are not spherical. Instead each p orbital consists of two sections called lobes that are on either side of the plane that passes through the nucleus. The probability density

* If probability density $|\psi|^2$ is constant on a given surface, $|\psi|$ is also constant over the surface. The boundary surface for $|\psi|^2$ and $|\psi|$ are identical.

function is zero on the plane where the two lobes touch each other. The size, shape and energy of the three orbitals are identical. They differ however, in the way the lobes are oriented. Since the lobes may be considered to lie along the x , y or z axis, they are given the designations $2p_x$, $2p_y$, and $2p_z$. It should be understood, however, that *there is no simple relation between the values of m_l ($-1, 0$ and $+1$) and the x , y and z directions.* For our purpose,

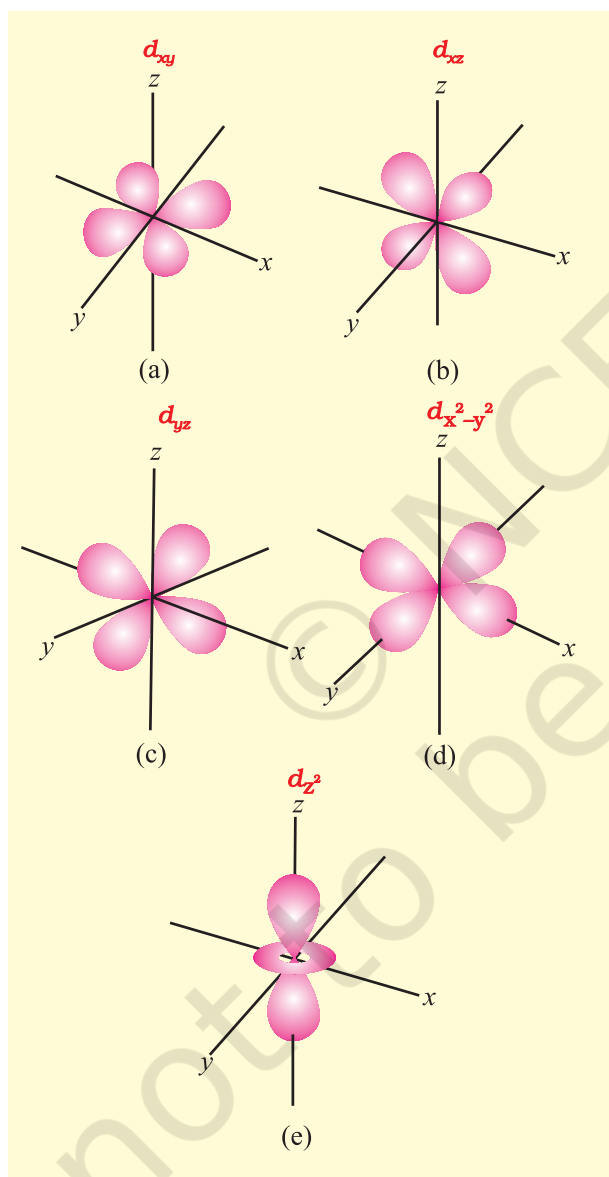

Fig. 2.15 Boundary surface diagrams of the five $3d$ orbitals.

it is sufficient to remember that, because there are three possible values of m_l , there are, therefore, three p orbitals whose axes are mutually perpendicular. Like s orbitals, p orbitals increase in size and energy with increase in the principal quantum number and hence the order of the energy and size of various p orbitals is $4p > 3p > 2p$. Further, like s orbitals, the probability density functions for p -orbital also pass through value zero, besides at zero and infinite distance, as the distance from the nucleus increases. The number of nodes are given by the $n - 2$, that is number of radial node is 1 for $3p$ orbital, two for $4p$ orbital and so on.

For $l = 2$, the orbital is known as d -orbital and the minimum value of principal quantum number (n) has to be 3, as the value of l cannot be greater than $n - 1$. There are five m_l values ($-2, -1, 0, +1$ and $+2$) for $l = 2$ and thus there are five d orbitals. The boundary surface diagram of d orbitals are shown in Fig. 2.15.

The five d -orbitals are designated as d_{xy} , d_{yz} , d_{xz} , $d_{x^2-y^2}$ and d_{z^2} . The shapes of the first four d -orbitals are similar to each other, where as that of the fifth one, d_{z^2} , is different from others, but all five $3d$ orbitals are equivalent in energy. The d orbitals for which n is greater than 3 ($4d, 5d...$) also have shapes similar to $3d$ orbital, but differ in energy and size.

Besides the radial nodes (i.e., probability density function is zero), the probability density functions for the np and nd orbitals are zero at the plane (s), passing through the nucleus (origin). For example, in case of p_z orbital, xy -plane is a nodal plane, in case of d_{xy} orbital, there are two nodal planes passing through the origin and bisecting the xy plane containing z -axis. These are called angular nodes and number of angular nodes are given by ' l ', i.e., one angular node for p orbitals, two angular nodes for ' d ' orbitals and so on. **The total number of nodes are given by $(n-1)$, i.e., sum of l angular nodes and $(n - l - 1)$ radial nodes.**

2.6.3 Energies of Orbitals

The energy of an electron in a hydrogen atom is determined solely by the principal quantum

number. Thus the energy of the orbitals in hydrogen atom increases as follows :

$$1s < 2s = 2p < 3s = 3p = 3d < 4s = 4p = 4d = 4f < \dots \quad (2.23)$$

and is depicted in Fig. 2.16. Although the shapes of 2s and 2p orbitals are different, an electron has the same energy when it is in the 2s orbital as when it is present in 2p orbital. The orbitals having the same energy are called **degenerate**. The 1s orbital in a hydrogen atom, as said earlier, corresponds to the most stable condition and is called the **ground state** and an electron residing in this orbital is most strongly held by the nucleus. An electron in the 2s, 2p or higher orbitals in a hydrogen atom is in **excited state**.

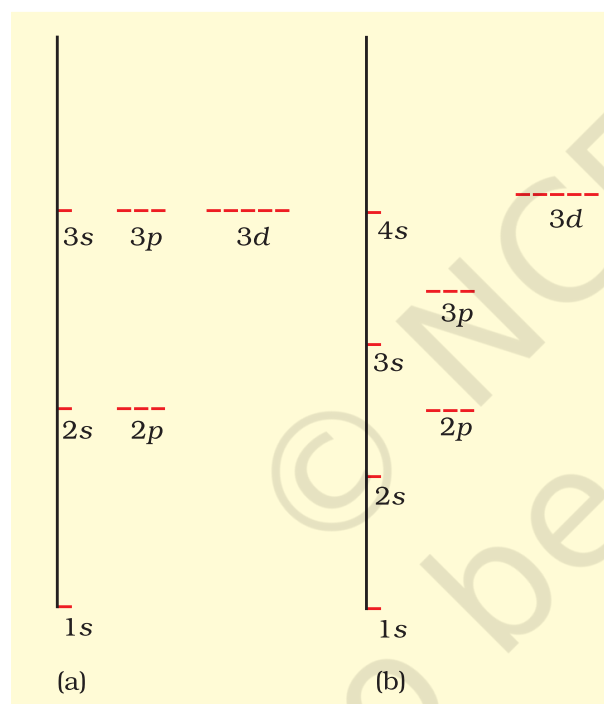

Fig. 2.16 Energy level diagrams for the few electronic shells of (a) hydrogen atom and (b) multi-electronic atoms. Note that orbitals for the same value of principal quantum number, have the same energies even for different azimuthal quantum number for hydrogen atom. In case of multi-electron atoms, orbitals with same principal quantum number possess different energies for different azimuthal quantum numbers.

The energy of an electron in a multi-electron atom, unlike that of the hydrogen atom, depends not only on its principal quantum number (shell), but also on its azimuthal quantum number (subshell). That is, for a given principal quantum number, s, p, d, f ... all have different energies. Within a given principal quantum number, the energy of orbitals increases in the order $s < p < d < f$. For higher energy levels, these differences are sufficiently pronounced and straggling of orbital energy may result, e.g., $4s < 3d$ and $6s < 5d$; $4f < 6p$. The main reason for having different energies of the subshells is the mutual repulsion among the electrons in multi-electron atoms. The only electrical interaction present in hydrogen atom is the attraction between the negatively charged electron and the positively charged nucleus. In multi-electron atoms, besides the presence of attraction between the electron and nucleus, there are repulsion terms between every electron and other electrons present in the atom. Thus the stability of an electron in a multi-electron atom is because total attractive interactions are more than the repulsive interactions. In general, the repulsive interaction of the electrons in the outer shell with the electrons in the inner shell are more important. On the other hand, the attractive interactions of an electron increases with increase of positive charge (Ze) on the nucleus. Due to the presence of electrons in the inner shells, the electron in the outer shell will not experience the full positive charge of the nucleus (Ze). The effect will be lowered due to the partial screening of positive charge on the nucleus by the inner shell electrons. This is known as the **shielding of the outer shell electrons from the nucleus by the inner shell electrons**, and the net positive charge experienced by the outer electrons is known as **effective nuclear charge** ($Z_{\text{eff}} e$). Despite the shielding of the outer electrons from the nucleus by the inner shell electrons, the attractive force experienced by the outer shell electrons increases with increase of nuclear charge. In other words, the energy of interaction between, the nucleus and electron

(that is orbital energy) decreases (that is more negative) with the increase of atomic number (Z).

Both the attractive and repulsive interactions depend upon the shell and shape of the orbital in which the electron is present. For example electrons present in spherical shaped, s orbital shields the outer electrons from the nucleus more effectively as compared to electrons present in p orbital. Similarly electrons present in p orbitals shield the outer electrons from the nucleus more than the electrons present in d orbitals, even though all these orbitals are present in the same shell. Further within a shell, due to spherical shape of s orbital, the s orbital electron spends more time close to the nucleus in comparison to p orbital electron which spends more time in the vicinity of nucleus in comparison to d orbital electron. In other words, for a given shell (principal quantum number), the Z_{eff} experienced by the electron decreases with increase of azimuthal quantum number (l), that is, the s orbital electron will be more tightly bound to the nucleus than p orbital electron which in turn will be better tightly bound than the d orbital electron. The energy of electrons in s orbital will be lower (more negative) than that of p orbital electron which will have less energy than that of d orbital electron and so on. Since the extent of shielding from the nucleus is different for electrons in different orbitals, it leads to the splitting of energy levels within the same shell (or same principal quantum number), that is, energy of electron in an orbital, as mentioned earlier, depends upon the values of n and l . Mathematically, the dependence of energies of the orbitals on n and l are quite complicated but one simple rule is that, **the lower the value of $(n + l)$ for an orbital, the lower is its energy. If two orbitals have the same value of $(n + l)$, the orbital with lower value of n will have the lower energy.** The Table 2.5 illustrates the $(n + l)$ rule and Fig. 2.16 depicts the energy levels of multi-electrons atoms. It may be noted that different subshells of a particular shell have different energies in case of multi-electrons atoms. However, in hydrogen atom, these have the

Table 2.5 Arrangement of Orbitals with Increasing Energy on the Basis of $(n+l)$ Rule

Orbital	Value of n	Value of l	Value of $(n + l)$	
1s	1	0	1 + 0 = 1	
2s	2	0	2 + 0 = 2	
2p	2	1	2 + 1 = 3	2p ($n=2$) has lower energy than
3s	3	0	3 + 0 = 3	3s ($n=3$)
3p	3	1	3 + 1 = 4	3p ($n=3$) has lower energy than
4s	4	0	4 + 0 = 4	4s ($n=4$)
3d	3	2	3 + 2 = 5	3d ($n=3$) has lower energy than
4p	4	1	4 + 1 = 5	4p ($n=4$)

same energy. Lastly it may be mentioned here that **energies of the orbitals in the same subshell decrease with increase in the atomic number (Z_{eff})**. For example, energy of 2s orbital of hydrogen atom is greater than that of 2s orbital of lithium and that of lithium is greater than that of sodium and so on, that is, $E_{2s}(\text{H}) > E_{2s}(\text{Li}) > E_{2s}(\text{Na}) > E_{2s}(\text{K})$.

2.6.4 Filling of Orbitals in Atom

The filling of electrons into the orbitals of different atoms takes place according to the *aufbau* principle which is based on the Pauli's exclusion principle, the Hund's rule of maximum multiplicity and the relative energies of the orbitals.

Aufbau Principle

The word '*aufbau*' in German means 'building up'. The building up of orbitals means the

filling up of orbitals with electrons. The principle states : **In the ground state of the atoms, the orbitals are filled in order of their increasing energies.** In other words, electrons first occupy the lowest energy orbital available to them and enter into higher energy orbitals only after the lower energy orbitals are filled. As you have learnt above, energy of a given orbital depends upon effective nuclear charge and different type of orbitals are affected to different extent. Thus, there is no single ordering of energies of orbitals which will be universally correct for all atoms.

However, following order of energies of the orbitals is extremely useful:

1s, 2s, 2p, 3s, 3p, 4s, 3d, 4p, 5s, 4d, 5p, 4f, 5d, 6p, 7s...

The order may be remembered by using the method given in Fig. 2.17. Starting from

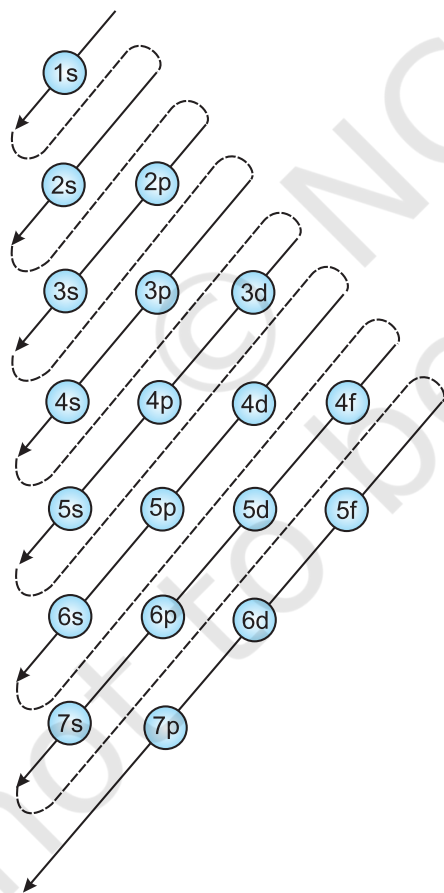

Fig.2.17 Order of filling of orbitals

the top, the direction of the arrows gives the order of filling of orbitals, that is starting from right top to bottom left. With respect to placement of outermost valence electrons, it is remarkably accurate for all atoms. For example, valence electron in potassium must choose between 3d and 4s orbitals and as predicted by this sequence, it is found in 4s orbital. The above order should be assumed to be a rough guide to the filling of energy levels. In many cases, the orbitals are similar in energy and small changes in atomic structure may bring about a change in the order of filling. Even then, the above series is a useful guide to the building of the electronic structure of an atom provided that it is remembered that exceptions may occur.

Pauli Exclusion Principle

The number of electrons to be filled in various orbitals is restricted by the exclusion principle, given by the Austrian scientist Wolfgang Pauli (1926). According to this principle : **No two electrons in an atom can have the same set of four quantum numbers.** Pauli exclusion principle can also be stated as : **“Only two electrons may exist in the same orbital and these electrons must have opposite spin.”**

This means that the two electrons can have the same value of three quantum numbers n , l and m_l , but must have the opposite spin quantum number. The restriction imposed by Pauli’s exclusion principle on the number of electrons in an orbital helps in calculating the capacity of electrons to be present in any subshell. For example, subshell 1s comprises one orbital and thus the maximum number of electrons present in 1s subshell can be two, in p and d subshells, the maximum number of electrons can be 6 and 10 and so on. This can be summed up as : **the maximum number of electrons in the shell with principal quantum number n is equal to $2n^2$.**

Hund’s Rule of Maximum Multiplicity

This rule deals with the filling of electrons into the orbitals belonging to the same subshell (that is, orbitals of equal energy, called **degenerate orbitals**). It states : **pairing of**

electrons in the orbitals belonging to the same subshell (*p*, *d* or *f*) does not take place until each orbital belonging to that subshell has got one electron each i.e., it is singly occupied.

Since there are three *p*, five *d* and seven *f* orbitals, therefore, the pairing of electrons will start in the *p*, *d* and *f* orbitals with the entry of 4th, 6th and 8th electron, respectively. It has been observed that half filled and fully filled degenerate set of orbitals acquire extra stability due to their symmetry (see Section, 2.6.7).

2.6.5 Electronic Configuration of Atoms

The distribution of electrons into orbitals of an atom is called its **electronic configuration**. If one keeps in mind the basic rules which govern the filling of different atomic orbitals, the electronic configurations of different atoms can be written very easily.

The electronic configuration of different atoms can be represented in two ways. For example :

(i) $s^a p^b d^c$ notation

(ii) Orbital diagram



In the first notation, the subshell is represented by the respective letter symbol and the number of electrons present in the subshell is depicted, as the super script, like *a*, *b*, *c*, ... etc. The similar subshell represented for different shells is differentiated by writing the principal quantum number before the respective subshell. In the second notation each orbital of the subshell is represented by a box and the electron is represented by an arrow (\uparrow) a positive spin or an arrow (\downarrow) a negative spin. The advantage of second notation over the first is that it represents all the four quantum numbers.

The hydrogen atom has only one electron which goes in the orbital with the lowest energy, namely 1*s*. The electronic configuration of the hydrogen atom is $1s^1$ meaning that it has one electron in the 1*s* orbital. The second electron in helium (He) can also occupy the

1*s* orbital. Its configuration is, therefore, $1s^2$. As mentioned above, the two electrons differ from each other with opposite spin, as can be seen from the orbital diagram.



The third electron of lithium (Li) is not allowed in the 1*s* orbital because of Pauli exclusion principle. It, therefore, takes the next available choice, namely the 2*s* orbital. The electronic configuration of Li is $1s^2 2s^1$. The 2*s* orbital can accommodate one more electron. The configuration of beryllium (Be) atom is, therefore, $1s^2 2s^2$ (see Table 2.6, page 66 for the electronic configurations of elements).

In the next six elements—boron (B, $1s^2 2s^2 2p^1$), carbon (C, $1s^2 2s^2 2p^2$), nitrogen (N, $1s^2 2s^2 2p^3$), oxygen (O, $1s^2 2s^2 2p^4$), fluorine (F, $1s^2 2s^2 2p^5$) and neon (Ne, $1s^2 2s^2 2p^6$), the 2*p* orbitals get progressively filled. This process is completed with the neon atom. The orbital picture of these elements can be represented as follows :

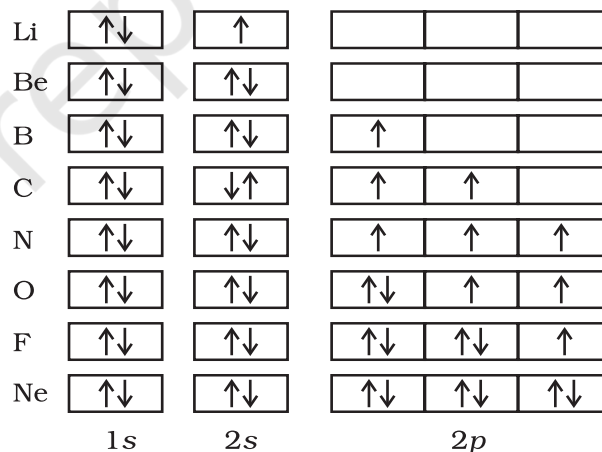

The electronic configuration of the elements sodium (Na, $1s^2 2s^2 2p^6 3s^1$) to argon (Ar, $1s^2 2s^2 2p^6 3s^2 3p^6$), follow exactly the same pattern as the elements from lithium to neon with the difference that the 3*s* and 3*p* orbitals are getting filled now. This process can be simplified if we represent the total number of electrons in the first two shells by the name of element neon (Ne). The electronic configuration of the elements from sodium to

argon can be written as (Na, [Ne]3s¹) to (Ar, [Ne] 3s²3p⁶). The electrons in the completely filled shells are known as core electrons and the electrons that are added to the electronic shell with the highest principal quantum number are called **valence electrons**. For example, the electrons in Ne are the core electrons and the electrons from Na to Ar are the valence electrons. In potassium (K) and calcium (Ca), the 4s orbital, being lower in energy than the 3d orbitals, is occupied by one and two electrons respectively.

A new pattern is followed beginning with scandium (Sc). The 3d orbital, being lower in energy than the 4p orbital, is filled first. Consequently, in the next ten elements, scandium (Sc), titanium (Ti), vanadium (V), chromium (Cr), manganese (Mn), iron (Fe), cobalt (Co), nickel (Ni), copper (Cu) and zinc (Zn), the five 3d orbitals are progressively occupied. We may be puzzled by the fact that chromium and copper have five and ten electrons in 3d orbitals rather than four and nine as their position would have indicated with two-electrons in the 4s orbital. The reason is that fully filled orbitals and half-filled orbitals have extra stability (that is, lower energy). Thus p³, p⁶, d⁵, d¹⁰, f⁷, f¹⁴ etc. configurations, which are either half-filled or fully filled, are more stable. Chromium and copper therefore adopt the d⁵ and d¹⁰ configuration (Section 2.6.7)[*caution: exceptions do exist*]

With the saturation of the 3d orbitals, the filling of the 4p orbital starts at gallium (Ga) and is complete at krypton (Kr). In the next eighteen elements from rubidium (Rb) to xenon (Xe), the pattern of filling the 5s, 4d and 5p orbitals are similar to that of 4s, 3d and 4p orbitals as discussed above. Then comes the turn of the 6s orbital. In caesium (Cs) and the barium (Ba), this orbital contains one and two electrons, respectively. Then from lanthanum (La) to mercury (Hg), the filling up of electrons takes place in 4f and 5d orbitals.

After this, filling of 6p, then 7s and finally 5f and 6d orbitals takes place. The elements after uranium (U) are all short-lived and all of them are produced artificially. The electronic configurations of the known elements (as determined by spectroscopic methods) are tabulated in Table 2.6 (page 66).

One may ask what is the utility of knowing the electron configuration? The modern approach to the chemistry, in fact, depends almost entirely on electronic distribution to understand and explain chemical behaviour. For example, questions like why two or more atoms combine to form molecules, why some elements are metals while others are non-metals, why elements like helium and argon are not reactive but elements like the halogens are reactive, find simple explanation from the electronic configuration. These questions have no answer in the Daltonian model of atom. A detailed understanding of the electronic structure of atom is, therefore, very essential for getting an insight into the various aspects of modern chemical knowledge.

2.6.6 Stability of Completely Filled and Half Filled Subshells

The ground state electronic configuration of the atom of an element always corresponds to the state of the lowest total electronic energy. The electronic configurations of most of the atoms follow the basic rules given in Section 2.6.5. However, in certain elements such as Cu, or Cr, where the two subshells (4s and 3d) differ slightly in their energies, an electron shifts from a subshell of lower energy (4s) to a subshell of higher energy (3d), provided such a shift results in all orbitals of the subshell of higher energy getting either completely filled or half filled. The valence electronic configurations of Cr and Cu, therefore, are 3d⁵ 4s¹ and 3d¹⁰ 4s¹ respectively and not 3d⁴ 4s² and 3d⁹ 4s². It has been found that there is extra stability associated with these electronic configurations.

Causes of Stability of Completely Filled and Half-filled Subshells

The completely filled and completely half-filled subshells are stable due to the following reasons:

1. Symmetrical distribution of electrons: It is well known that symmetry leads to stability. The completely filled or half filled subshells have symmetrical distribution of electrons in them and are therefore more stable. Electrons in the same subshell (here $3d$) have equal energy but different spatial distribution. Consequently, their shielding of one-another is relatively small and the electrons are more strongly attracted by the nucleus.

2. Exchange Energy : The stabilizing effect arises whenever two or more electrons with the same spin are present in the degenerate orbitals of a subshell. These electrons tend to exchange their positions and the energy released due to this exchange is called exchange energy. The number of exchanges that can take place is maximum when the subshell is either half filled or completely filled (Fig. 2.18). As a result the exchange energy is maximum and so is the stability.

You may note that the exchange energy is at the basis of Hund's rule that electrons which enter orbitals of equal energy have parallel spins as far as possible. In other words, the extra stability of half-filled and completely filled subshell is due to: (i) relatively small shielding, (ii) smaller coulombic repulsion energy, and (iii) larger exchange energy. Details about the exchange energy will be dealt with in higher classes.

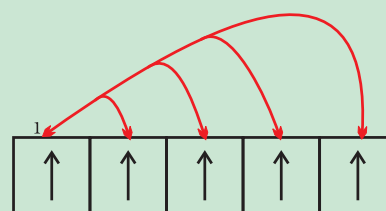

4 exchange by electron 1

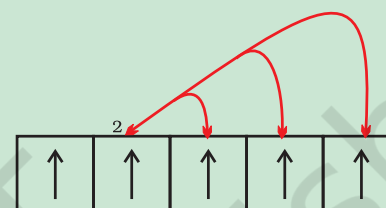

3 exchange by electron 2

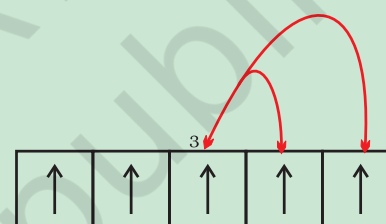

2 exchange by electron 3

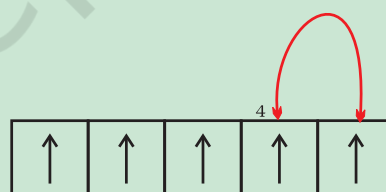

1 exchange by electron 4

Fig. 2.18 Possible exchange for a d^5 configuration

Table 2.6 Electronic Configurations of the Elements

Element	Z	1s	2s	2p	3s	3p	3d	4s	4p	4d	4f	5s	5p	5d	5f	6s	6p	6d	7s
H	1	1																	
He	2	2																	
Li	3	2	1																
Be	4	2	2																
B	5	2	2	1															
C	6	2	2	2															
N	7	2	2	3															
O	8	2	2	4															
F	9	2	2	5															
Ne	10	2	2	6															
Na	11	2	2	6	1														
Mg	12	2	2	6	2														
Al	13	2	2	6	2	1													
Si	14	2	2	6	2	2													
P	15	2	2	6	2	3													
S	16	2	2	6	2	4													
Cl	17	2	2	6	2	5													
Ar	18	2	2	6	2	6													
K	19	2	2	6	2	6		1											
Ca	20	2	2	6	2	6		2											
Sc	21	2	2	6	2	6	1	2											
Ti	22	2	2	6	2	6	2	2											
V	23	2	2	6	2	6	3	2											
Cr*	24	2	2	6	2	6	5	1											
Mn	25	2	2	6	2	6	5	2											
Fe	26	2	2	6	2	6	6	2											
Co	27	2	2	6	2	6	7	2											
Ni	28	2	2	6	2	6	8	2											
Cu*	29	2	2	6	2	6	10	1											
Zn	30	2	2	6	2	6	10	2											
Ga	31	2	2	6	2	6	10	2	1										
Ge	32	2	2	6	2	6	10	2	2										
As	33	2	2	6	2	6	10	2	3										
Se	34	2	2	6	2	6	10	2	4										
Br	35	2	2	6	2	6	10	2	5										
Kr	36	2	2	6	2	6	10	2	6										
Rb	37	2	2	6	2	6	10	2	6			1							
Sr	38	2	2	6	2	6	10	2	6			2							
Y	39	2	2	6	2	6	10	2	6	1		2							
Zr	40	2	2	6	2	6	10	2	6	2		2							
Nb*	41	2	2	6	2	6	10	2	6	4		1							
Mo*	42	2	2	6	2	6	10	2	6	5		1							
Tc	43	2	2	6	2	6	10	2	6	5		2							
Ru*	44	2	2	6	2	6	10	2	6	7		1							
Rh*	45	2	2	6	2	6	10	2	6	8		1							
Pd*	46	2	2	6	2	6	10	2	6	10									
Ag*	47	2	2	6	2	6	10	2	6	10		1							
Cd	48	2	2	6	2	6	10	2	6	10		2							
In	49	2	2	6	2	6	10	2	6	10		2	1						
Sn	50	2	2	6	2	6	10	2	6	10		2	2						
Sb	51	2	2	6	2	6	10	2	6	10		2	3						
Te	52	2	2	6	2	6	10	2	6	10		2	4						
I	53	2	2	6	2	6	10	2	6	10		2	5						
Xe	54	2	2	6	2	6	10	2	6	10		2	6						

* Elements with exceptional electronic configurations

Element	Z	1s	2s	2p	3s	3p	3d	4s	4p	4d	4f	5s	5p	5d	5f	6s	6p	6d	7s
Cs	55	2	2	6	2	6	10	2	6	10		2	6			1			
Ba	56	2	2	6	2	6	10	2	6	10		2	6			2			
La*	57	2	2	6	2	6	10	2	6	10		2	6	1		2			
Ce*	58	2	2	6	2	6	10	2	6	10	2	2	6			2			
Pr	59	2	2	6	2	6	10	2	6	10	3	2	6			2			
Nd	60	2	2	6	2	6	10	2	6	10	4	2	6			2			
Pm	61	2	2	6	2	6	10	2	6	10	5	2	6			2			
Sm	62	2	2	6	2	6	10	2	6	10	6	2	6			2			
Eu	63	2	2	6	2	6	10	2	6	10	7	2	6			2			
Gd*	64	2	2	6	2	6	10	2	6	10	7	2	6	1		2			
Tb	65	2	2	6	2	6	10	2	6	10	9	2	6			2			
Dy	66	2	2	6	2	6	10	2	6	10	10	2	6			2			
Ho	67	2	2	6	2	6	10	2	6	10	11	2	6			2			
Er	68	2	2	6	2	6	10	2	6	10	12	2	6			2			
Tm	69	2	2	6	2	6	10	2	6	10	13	2	6			2			
Yb	70	2	2	6	2	6	10	2	6	10	14	2	6			2			
Lu	71	2	2	6	2	6	10	2	6	10	14	2	6	1		2			
Hf	72	2	2	6	2	6	10	2	6	10	14	2	6	2		2			
Ta	73	2	2	6	2	6	10	2	6	10	14	2	6	3		2			
W	74	2	2	6	2	6	10	2	6	10	14	2	6	4		2			
Re	75	2	2	6	2	6	10	2	6	10	14	2	6	5		2			
Os	76	2	2	6	2	6	10	2	6	10	14	2	6	6		2			
Ir	77	2	2	6	2	6	10	2	6	10	14	2	6	7		2			
Pt*	78	2	2	6	2	6	10	2	6	10	14	2	6	9		1			
Au*	79	2	2	6	2	6	10	2	6	10	14	2	6	10		1			
Hg	80	2	2	6	2	6	10	2	6	10	14	2	6	10		2			
Tl	81	2	2	6	2	6	10	2	6	10	14	2	6	10		2	1		
Pb	82	2	2	6	2	6	10	2	6	10	14	2	6	10		2	2		
Bi	83	2	2	6	2	6	10	2	6	10	14	2	6	10		2	3		
Po	84	2	2	6	2	6	10	2	6	10	14	2	6	10		2	4		
At	85	2	2	6	2	6	10	2	6	10	14	2	6	10		2	5		
Rn	86	2	2	6	2	6	10	2	6	10	14	2	6	10		2	6		
Fr	87	2	2	6	2	6	10	2	6	10	14	2	6	10		2	6		1
Ra	88	2	2	6	2	6	10	2	6	10	14	2	6	10		2	6		2
Ac	89	2	2	6	2	6	10	2	6	10	14	2	6	10		2	6	1	2
Th	90	2	2	6	2	6	10	2	6	10	14	2	6	10		2	6	2	2
Pa	91	2	2	6	2	6	10	2	6	10	14	2	6	10	2	2	6	1	2
U	92	2	2	6	2	6	10	2	6	10	14	2	6	10	3	2	6	1	2
Np	93	2	2	6	2	6	10	2	6	10	14	2	6	10	4	2	6	1	2
Pu	94	2	2	6	2	6	10	2	6	10	14	2	6	10	6	2	6		2
Am	95	2	2	6	2	6	10	2	6	10	14	2	6	10	7	2	6		2
Cm	96	2	2	6	2	6	10	2	6	10	14	2	6	10	7	2	6	1	2
Bk	97	2	2	6	2	6	10	2	6	10	14	2	6	10	8	2	6	1	2
Cf	98	2	2	6	2	6	10	2	6	10	14	2	6	10	10	2	6		2
Es	99	2	2	6	2	6	10	2	6	10	14	2	6	10	11	2	6		2
Fm	100	2	2	6	2	6	10	2	6	10	14	2	6	10	12	2	6		2
Md	101	2	2	6	2	6	10	2	6	10	14	2	6	10	13	2	6		2
No	102	2	2	6	2	6	10	2	6	10	14	2	6	10	14	2	6		2
Lr	103	2	2	6	2	6	10	2	6	10	14	2	6	10	14	2	6	1	2
Rf	104	2	2	6	2	6	10	2	6	10	14	2	6	10	10	2	6	2	2
Db	105	2	2	6	2	6	10	2	6	10	14	2	6	10	11	2	6	3	2
Sg	106	2	2	6	2	6	10	2	6	10	14	2	6	10	12	2	6	4	2
Bh	107	2	2	6	2	6	10	2	6	10	14	2	6	10	13	2	6	5	2
Hs	108	2	2	6	2	6	10	2	6	10	14	2	6	10	14	2	6	6	2
Mt	109	2	2	6	2	6	10	2	6	10	14	2	6	10	14	2	6	7	2
Ds	110	2	2	6	2	6	10	2	6	10	14	2	6	10	14	2	6	8	2
Rg**	111	2	2	6	2	6	10	2	6	10	14	2	6	10	14	2	6	10	1

** Elements with atomic number 112 and above have been reported but not yet fully authenticated and named.

SUMMARY

Atoms are the building blocks of elements. They are the smallest parts of an element that chemically react. The first atomic theory, proposed by John Dalton in 1808, regarded atom as the ultimate indivisible particle of matter. Towards the end of the nineteenth century, it was proved experimentally that atoms are divisible and consist of three fundamental particles: **electrons, protons** and **neutrons**. The discovery of sub-atomic particles led to the proposal of various atomic models to explain the structure of atom.

Thomson in 1898 proposed that an atom consists of uniform sphere of positive electricity with electrons embedded into it. This model in which mass of the atom is considered to be evenly spread over the atom was proved wrong by Rutherford's famous alpha-particle scattering experiment in 1909. Rutherford concluded that atom is made of a tiny positively charged **nucleus**, at its centre with electrons revolving around it in **circular orbits**. **Rutherford model**, which resembles the solar system, was no doubt an improvement over **Thomson model** but it could not account for the stability of the atom i.e., why the electron does not fall into the nucleus. Further, it was also silent about the electronic structure of atoms i.e., about the distribution and relative energies of electrons around the nucleus. The difficulties of the Rutherford model were overcome by Niels Bohr in 1913 in his model of the hydrogen atom. Bohr postulated that electron moves around the nucleus in circular orbits. Only certain orbits can exist and each orbit corresponds to a specific energy. Bohr calculated the energy of electron in various orbits and for each orbit predicted the distance between the electron and nucleus. **Bohr model**, though offering a satisfactory model for explaining the spectra of the hydrogen atom, could not explain the spectra of multi-electron atoms. The reason for this was soon discovered. In Bohr model, an electron is regarded as a charged particle moving in a well defined circular orbit about the nucleus. The wave character of the electron is ignored in Bohr's theory. An orbit is a clearly defined path and this path can completely be defined only if both the exact position and the exact velocity of the electron at the same time are known. This is not possible according to the Heisenberg uncertainty principle. Bohr model of the hydrogen atom, therefore, not only ignores the dual behaviour of electron but also contradicts **Heisenberg uncertainty principle**.

Erwin Schrödinger, in 1926, proposed an equation called Schrödinger equation to describe the electron distributions in space and the allowed energy levels in atoms. This equation incorporates de Broglie's concept of **wave-particle duality** and is consistent with Heisenberg uncertainty principle. When Schrödinger equation is solved for the electron in a hydrogen atom, the solution gives the possible energy states the electron can occupy [and the corresponding wave function(s) (ψ) (which in fact are the mathematical functions) of the electron associated with each energy state]. These quantized energy states and corresponding wave functions which are characterized by a set of three quantum numbers (**principal quantum number n** , **azimuthal quantum number l** and **magnetic quantum number m_l**) arise as a natural consequence in the solution of the Schrödinger equation. The restrictions on the values of these three quantum numbers also come naturally from this solution. The quantum mechanical model of the hydrogen atom successfully predicts all aspects of the hydrogen atom spectrum including some phenomena that could not be explained by the Bohr model.

According to the quantum mechanical model of the atom, the electron distribution of an atom containing a number of electrons is divided into **shells**. The shells, in turn, are thought to consist of one or more **subshells** and subshells are assumed to be composed of one or more orbitals, which the electrons occupy. While for hydrogen and hydrogen like systems (such as He^+ , Li^{2+} etc.) all the orbitals within a given shell have same energy, the energy of the orbitals in a multi-electron atom depends upon the values of n and l : The lower the value of $(n + l)$ for an orbital, the lower is its energy. If two orbitals have the same $(n + l)$ value, the orbital with lower value of n has the lower energy. In an atom many such orbitals are

possible and electrons are filled in those orbitals in order of increasing energy in accordance with **Pauli exclusion principle** (no two electrons in an atom can have the same set of four quantum numbers) and **Hund's rule of maximum multiplicity** (pairing of electrons in the orbitals belonging to the same subshell does not take place until each orbital belonging to that subshell has got one electron each, i.e., is singly occupied). This forms the basis of the electronic structure of atoms.

EXERCISES

- 2.1 (i) Calculate the number of electrons which will together weigh one gram.
(ii) Calculate the mass and charge of one mole of electrons.
- 2.2 (i) Calculate the total number of electrons present in one mole of methane.
(ii) Find (a) the total number and (b) the total mass of neutrons in 7 mg of ^{14}C . (Assume that mass of a neutron = 1.675×10^{-27} kg).
(iii) Find (a) the total number and (b) the total mass of protons in 34 mg of NH_3 at STP.
Will the answer change if the temperature and pressure are changed ?
- 2.3 How many neutrons and protons are there in the following nuclei ?
 $^{13}_6\text{C}$, $^{16}_8\text{O}$, $^{24}_{12}\text{Mg}$, $^{56}_{26}\text{Fe}$, $^{88}_{38}\text{Sr}$
- 2.4 Write the complete symbol for the atom with the given atomic number (Z) and atomic mass (A)
(i) $Z = 17$, $A = 35$.
(ii) $Z = 92$, $A = 233$.
(iii) $Z = 4$, $A = 9$.
- 2.5 Yellow light emitted from a sodium lamp has a wavelength (λ) of 580 nm. Calculate the frequency (ν) and wavenumber ($\bar{\nu}$) of the yellow light.
- 2.6 Find energy of each of the photons which
(i) correspond to light of frequency 3×10^{15} Hz.
(ii) have wavelength of 0.50 Å.
- 2.7 Calculate the wavelength, frequency and wavenumber of a light wave whose period is 2.0×10^{-10} s.
- 2.8 What is the number of photons of light with a wavelength of 4000 pm that provide 1J of energy?
- 2.9 A photon of wavelength 4×10^{-7} m strikes on metal surface, the work function of the metal being 2.13 eV. Calculate (i) the energy of the photon (eV), (ii) the kinetic energy of the emission, and (iii) the velocity of the photoelectron ($1 \text{ eV} = 1.6020 \times 10^{-19} \text{ J}$).
- 2.10 Electromagnetic radiation of wavelength 242 nm is just sufficient to ionise the sodium atom. Calculate the ionisation energy of sodium in kJ mol^{-1} .
- 2.11 A 25 watt bulb emits monochromatic yellow light of wavelength of $0.57 \mu\text{m}$. Calculate the rate of emission of quanta per second.
- 2.12 Electrons are emitted with zero velocity from a metal surface when it is exposed to radiation of wavelength 6800 Å. Calculate threshold frequency (ν_0) and work function (W_0) of the metal.
- 2.13 What is the wavelength of light emitted when the electron in a hydrogen atom undergoes transition from an energy level with $n = 4$ to an energy level with $n = 2$?

- 2.14 How much energy is required to ionise a H atom if the electron occupies $n = 5$ orbit? Compare your answer with the ionization enthalpy of H atom (energy required to remove the electron from $n = 1$ orbit).
- 2.15 What is the maximum number of emission lines when the excited electron of a H atom in $n = 6$ drops to the ground state?
- 2.16 (i) The energy associated with the first orbit in the hydrogen atom is -2.18×10^{-18} J atom⁻¹. What is the energy associated with the fifth orbit?
(ii) Calculate the radius of Bohr's fifth orbit for hydrogen atom.
- 2.17 Calculate the wavenumber for the longest wavelength transition in the Balmer series of atomic hydrogen.
- 2.18 What is the energy in joules, required to shift the electron of the hydrogen atom from the first Bohr orbit to the fifth Bohr orbit and what is the wavelength of the light emitted when the electron returns to the ground state? The ground state electron energy is -2.18×10^{-11} ergs.
- 2.19 The electron energy in hydrogen atom is given by $E_n = (-2.18 \times 10^{-18})/n^2$ J. Calculate the energy required to remove an electron completely from the $n = 2$ orbit. What is the longest wavelength of light in cm that can be used to cause this transition?
- 2.20 Calculate the wavelength of an electron moving with a velocity of 2.05×10^7 m s⁻¹.
- 2.21 The mass of an electron is 9.1×10^{-31} kg. If its K.E. is 3.0×10^{-25} J, calculate its wavelength.
- 2.22 Which of the following are isoelectronic species i.e., those having the same number of electrons?
Na⁺, K⁺, Mg²⁺, Ca²⁺, S²⁻, Ar.
- 2.23 (i) Write the electronic configurations of the following ions: (a) H⁻ (b) Na⁺ (c) O²⁻ (d) F⁻
(ii) What are the atomic numbers of elements whose outermost electrons are represented by (a) 3s¹ (b) 2p³ and (c) 3p⁵ ?
(iii) Which atoms are indicated by the following configurations ?
(a) [He] 2s¹ (b) [Ne] 3s² 3p³ (c) [Ar] 4s² 3d¹.
- 2.24 What is the lowest value of n that allows g orbitals to exist?
- 2.25 An electron is in one of the 3d orbitals. Give the possible values of n , l and m_l for this electron.
- 2.26 An atom of an element contains 29 electrons and 35 neutrons. Deduce (i) the number of protons and (ii) the electronic configuration of the element.
- 2.27 Give the number of electrons in the species H₂⁺, H₂ and O₂⁺
- 2.28 (i) An atomic orbital has $n = 3$. What are the possible values of l and m_l ?
(ii) List the quantum numbers (m_l and l) of electrons for 3d orbital.
(iii) Which of the following orbitals are possible?
1p, 2s, 2p and 3f
- 2.29 Using s, p, d notations, describe the orbital with the following quantum numbers.
(a) $n=1, l=0$; (b) $n = 3; l=1$ (c) $n = 4; l=2$; (d) $n=4; l=3$.
- 2.30 Explain, giving reasons, which of the following sets of quantum numbers are not possible.
- | | | | | |
|-----|----------|----------|------------|-----------------------|
| (a) | $n = 0,$ | $l = 0,$ | $m_l = 0,$ | $m_s = + \frac{1}{2}$ |
| (b) | $n = 1,$ | $l = 0,$ | $m_l = 0,$ | $m_s = - \frac{1}{2}$ |
| (c) | $n = 1,$ | $l = 1,$ | $m_l = 0,$ | $m_s = + \frac{1}{2}$ |
| (d) | $n = 2,$ | $l = 1,$ | $m_l = 0,$ | $m_s = - \frac{1}{2}$ |

- 2.48 In astronomical observations, signals observed from the distant stars are generally weak. If the photon detector receives a total of 3.15×10^{-18} J from the radiations of 600 nm, calculate the number of photons received by the detector.
- 2.49 Lifetimes of the molecules in the excited states are often measured by using pulsed radiation source of duration nearly in the nano second range. If the radiation source has the duration of 2 ns and the number of photons emitted during the pulse source is 2.5×10^{15} , calculate the energy of the source.
- 2.50 The longest wavelength doublet absorption transition is observed at 589 and 589.6 nm. Calculate the frequency of each transition and energy difference between two excited states.
- 2.51 The work function for caesium atom is 1.9 eV. Calculate (a) the threshold wavelength and (b) the threshold frequency of the radiation. If the caesium element is irradiated with a wavelength 500 nm, calculate the kinetic energy and the velocity of the ejected photoelectron.
- 2.52 Following results are observed when sodium metal is irradiated with different wavelengths. Calculate (a) threshold wavelength and, (b) Planck's constant.
- | | | | |
|--|------|------|------|
| λ (nm) | 500 | 450 | 400 |
| $\nu \times 10^{-5}$ (cm s ⁻¹) | 2.55 | 4.35 | 5.35 |
- 2.53 The ejection of the photoelectron from the silver metal in the photoelectric effect experiment can be stopped by applying the voltage of 0.35 V when the radiation 256.7 nm is used. Calculate the work function for silver metal.
- 2.54 If the photon of the wavelength 150 pm strikes an atom and one of its inner bound electrons is ejected out with a velocity of 1.5×10^7 m s⁻¹, calculate the energy with which it is bound to the nucleus.
- 2.55 Emission transitions in the Paschen series end at orbit $n = 3$ and start from orbit n and can be represented as $\nu = 3.29 \times 10^{15}$ (Hz) $[1/3^2 - 1/n^2]$
Calculate the value of n if the transition is observed at 1285 nm. Find the region of the spectrum.
- 2.56 Calculate the wavelength for the emission transition if it starts from the orbit having radius 1.3225 nm and ends at 211.6 pm. Name the series to which this transition belongs and the region of the spectrum.
- 2.57 Dual behaviour of matter proposed by de Broglie led to the discovery of electron microscope often used for the highly magnified images of biological molecules and other type of material. If the velocity of the electron in this microscope is 1.6×10^6 ms⁻¹, calculate de Broglie wavelength associated with this electron.
- 2.58 Similar to electron diffraction, neutron diffraction microscope is also used for the determination of the structure of molecules. If the wavelength used here is 800 pm, calculate the characteristic velocity associated with the neutron.
- 2.59 If the velocity of the electron in Bohr's first orbit is 2.19×10^6 ms⁻¹, calculate the de Broglie wavelength associated with it.
- 2.60 The velocity associated with a proton moving in a potential difference of 1000 V is 4.37×10^5 ms⁻¹. If the hockey ball of mass 0.1 kg is moving with this velocity, calculate the wavelength associated with this velocity.
- 2.61 If the position of the electron is measured within an accuracy of ± 0.002 nm, calculate the uncertainty in the momentum of the electron. Suppose the momentum of the electron is $h/4\pi m \times 0.05$ nm, is there any problem in defining this value.
- 2.62 The quantum numbers of six electrons are given below. Arrange them in order of increasing energies. If any of these combination(s) has/have the same energy lists:
- $n = 4, l = 2, m_l = -2, m_s = -1/2$
 - $n = 3, l = 2, m_l = 1, m_s = +1/2$

3. $n = 4, l = 1, m_l = 0, m_s = +1/2$
 4. $n = 3, l = 2, m_l = -2, m_s = -1/2$
 5. $n = 3, l = 1, m_l = -1, m_s = +1/2$
 6. $n = 4, l = 1, m_l = 0, m_s = +1/2$
- 2.63 The bromine atom possesses 35 electrons. It contains 6 electrons in $2p$ orbital, 6 electrons in $3p$ orbital and 5 electron in $4p$ orbital. Which of these electron experiences the lowest effective nuclear charge ?
- 2.64 Among the following pairs of orbitals which orbital will experience the larger effective nuclear charge? (i) $2s$ and $3s$, (ii) $4d$ and $4f$, (iii) $3d$ and $3p$.
- 2.65 The unpaired electrons in Al and Si are present in $3p$ orbital. Which electrons will experience more effective nuclear charge from the nucleus ?
- 2.66 Indicate the number of unpaired electrons in : (a) P, (b) Si, (c) Cr, (d) Fe and (e) Kr.
- 2.67 (a) How many subshells are associated with $n = 4$? (b) How many electrons will be present in the subshells having m_s value of $-1/2$ for $n = 4$?



11082CH03

UNIT 3

CLASSIFICATION OF ELEMENTS AND PERIODICITY IN PROPERTIES

Objectives

After studying this Unit, you will be able to

- appreciate how the concept of grouping elements in accordance to their properties led to the development of Periodic Table.
- understand the Periodic Law;
- understand the significance of atomic number and electronic configuration as the basis for periodic classification;
- name the elements with $Z > 100$ according to IUPAC nomenclature;
- classify elements into *s*, *p*, *d*, *f* blocks and learn their main characteristics;
- recognise the periodic trends in physical and chemical properties of elements;
- compare the reactivity of elements and correlate it with their occurrence in nature;
- explain the relationship between ionization enthalpy and metallic character;
- use scientific vocabulary appropriately to communicate ideas related to certain important properties of atoms e.g., atomic/ionic radii, ionization enthalpy, electron gain enthalpy, electronegativity, valence of elements.

“The Periodic Table is arguably the most important concept in chemistry, both in principle and in practice. It is the everyday support for students, it suggests new avenues of research to professionals, and it provides a succinct organization of the whole of chemistry. It is a remarkable demonstration of the fact that the chemical elements are not a random cluster of entities but instead display trends and lie together in families. An awareness of the Periodic Table is essential to anyone who wishes to disentangle the world and see how it is built up from the fundamental building blocks of the chemistry, the chemical elements.”

Glenn T. Seaborg

In this Unit, we will study the historical development of the Periodic Table as it stands today and the Modern Periodic Law. We will also learn how the periodic classification follows as a logical consequence of the electronic configuration of atoms. Finally, we shall examine some of the periodic trends in the physical and chemical properties of the elements.

3.1 WHY DO WE NEED TO CLASSIFY ELEMENTS ?

We know by now that the elements are the basic units of all types of matter. In 1800, only 31 elements were known. By 1865, the number of identified elements had more than doubled to 63. At present 114 elements are known. Of them, the recently discovered elements are man-made. Efforts to synthesise new elements are continuing. With such a large number of elements it is very difficult to study individually the chemistry of all these elements and their innumerable compounds individually. To ease out this problem, scientists searched for a systematic way to organise their knowledge by classifying the elements. Not only that it would rationalize known chemical facts about elements, but even predict new ones for undertaking further study.

3.2 GENESIS OF PERIODIC CLASSIFICATION

Classification of elements into groups and development of Periodic Law and Periodic Table are the consequences of systematising the knowledge gained by a number of scientists through their observations and experiments. The German chemist, Johann Dobereiner in early 1800's was the first to consider the idea of trends among properties of elements. By 1829 he noted a similarity among the physical and chemical properties of several groups of three elements (**Triads**). In each case, he noticed that the middle element of each of the **Triads** had an atomic weight about half way between the atomic weights of the other two (Table 3.1). Also the properties of the middle element were in between those of the other two members. Since Dobereiner's

the periodic recurrence of properties. This also did not attract much attention. The English chemist, John Alexander Newlands in 1865 profounded the **Law of Octaves**. He arranged the elements in increasing order of their atomic weights and noted that every eighth element had properties similar to the first element (Table 3.2). The relationship was just like every eighth note that resembles the first in octaves of music. Newlands's Law of Octaves seemed to be true only for elements up to calcium. Although his idea was not widely accepted at that time, he, for his work, was later awarded Davy Medal in 1887 by the Royal Society, London.

The Periodic Law, as we know it today owes its development to the Russian chemist, Dmitri Mendeleev (1834-1907) and the German chemist, Lothar Meyer (1830-1895).

Table 3.1 Dobereiner's Triads

Element	Atomic weight	Element	Atomic weight	Element	Atomic weight
Li	7	Ca	40	Cl	35.5
Na	23	Sr	88	Br	80
K	39	Ba	137	I	127

relationship, referred to as the **Law of Triads**, seemed to work only for a few elements, it was dismissed as coincidence. The next reported attempt to classify elements was made by a French geologist, A.E.B. de Chancourtois in 1862. He arranged the then known elements in order of increasing atomic weights and made a cylindrical table of elements to display

Working independently, both the chemists in 1869 proposed that on arranging elements in the increasing order of their atomic weights, similarities appear in physical and chemical properties at regular intervals. Lothar Meyer plotted the physical properties such as atomic volume, melting point and boiling point against atomic weight and obtained

Table 3.2 Newlands' Octaves

Element	Li	Be	B	C	N	O	F
At. wt.	7	9	11	12	14	16	19
Element	Na	Mg	Al	Si	P	S	Cl
At. wt.	23	24	27	29	31	32	35.5
Element	K	Ca					
At. wt.	39	40					

a periodically repeated pattern. Unlike Newlands, Lothar Meyer observed a change in length of that repeating pattern. By 1868, Lothar Meyer had developed a table of the elements that closely resembles the Modern Periodic Table. However, his work was not published until after the work of Dmitri Mendeleev, the scientist who is generally credited with the development of the Modern Periodic Table.

While Dobereiner initiated the study of periodic relationship, it was Mendeleev who was responsible for publishing the Periodic Law for the first time. It states as follows :

The properties of the elements are a periodic function of their atomic weights.

Mendeleev arranged elements in horizontal rows and vertical columns of a table in order of their increasing atomic weights in such a way that the elements with similar properties occupied the same vertical column or group. Mendeleev's system of classifying elements was more elaborate than that of Lothar Meyer's. He fully recognized the significance of periodicity and used broader range of physical and chemical properties to classify the elements. In particular, Mendeleev relied on the similarities in the empirical formulas and properties of the compounds formed by the elements. He realized that some of the elements did not fit in with his scheme of

classification if the order of atomic weight was strictly followed. He ignored the order of atomic weights, thinking that the atomic measurements might be incorrect, and placed the elements with similar properties together. For example, iodine with lower atomic weight than that of tellurium (Group VI) was placed in Group VII along with fluorine, chlorine, bromine because of similarities in properties (Fig. 3.1). At the same time, keeping his primary aim of arranging the elements of similar properties in the same group, he proposed that some of the elements were still undiscovered and, therefore, left several gaps in the table. For example, both gallium and germanium were unknown at the time Mendeleev published his Periodic Table. He left the gap under aluminium and a gap under silicon, and called these elements **Eka-Aluminium** and **Eka-Silicon**. Mendeleev predicted not only the existence of gallium and germanium, but also described some of their general physical properties. These elements were discovered later. Some of the properties predicted by Mendeleev for these elements and those found experimentally are listed in Table 3.3.

The boldness of Mendeleev's quantitative predictions and their eventual success made him and his Periodic Table famous. Mendeleev's Periodic Table published in 1905 is shown in Fig. 3.1.

Table 3.3 Mendeleev's Predictions for the Elements Eka-aluminium (Gallium) and Eka-silicon (Germanium)

Property	Eka-aluminium (predicted)	Gallium (found)	Eka-silicon (predicted)	Germanium (found)
Atomic weight	68	70	72	72.6
Density/(g/cm ³)	5.9	5.94	5.5	5.36
Melting point/K	Low	302.93	High	1231
Formula of oxide	E ₂ O ₃	Ga ₂ O ₃	EO ₂	GeO ₂
Formula of chloride	E Cl ₃	GaCl ₃	ECl ₄	GeCl ₄

PERIODIC SYSTEM OF THE ELEMENTS IN GROUPS AND SERIES

SERIES	GROUPS OF ELEMENTS										
	0	I	II	III	IV	V	VI	VII	VIII		
1	Helium He 4.0	Hydrogen H 1.008	Beryllium Be 9.1	Boron B 11.0	Carbon C 12.0	Nitrogen N 14.04	Oxygen O 16.00	Fluorine F 19.0	Iron Fe 55.9		
2		Lithium Li 7.03	Magnesium Mg 24.3	Aluminium Al 27.0	Silicon Si 28.4	Phosphorus P 31.0	Sulphur S 32.06	Chlorine Cl 35.45	Cobalt Co 59		
3		Sodium Na 23.5							Nickel Ni 59		
4	Argon Ar 38	Potassium K 39.1	Calcium Ca 40.1	Scandium Sc 44.1	Titanium Ti 48.1	Vanadium V 51.4	Chromium Cr 52.1	Manganese Mn 55.0	Iron Fe 55.9		
5		Copper Cu 63.6	Zinc Zn 65.4	Gallium Ga 70.0	Germanium Ge 72.3	Arsenic As 75	Selenium Se 79	Bromine Br 79.95			
6	Krypton Kr 81.8	Rubidium Rb 85.4	Strontium Sr 87.6	Yttrium Y 89.0	Zirconium Zr 90.6	Niobium Nb 94.0	Molybdenum Mo 96.0		Ruthenium Ru 101.7		
7		Silver Ag 107.9	Cadmium Cd 112.4	Indium In 114.0	Tin Sn 119.0	Antimony Sb 120.0	Tellurium Te 127.6	Iodine I 126.9	Rhodium Rh 103.0		
8	Xenon Xe 128	Caesium Cs 132.9	Barium Ba 137.4	Lanthanum La 139	Cerium Ce 140						
9											
10				Ytterbium Yb 173	Tantalum Ta 183		Tungsten W 184		Osmium Os 191		
11			Mercury Hg 200.0	Thallium Tl 204.1	Lead Pb 206.9	Bismuth Bi 208			Iridium Ir 193		
12			Radium Ra 224		Thorium Th 232		Uranium U 239		Platinum Pt 194.9		
	R	R ₂ O	RO	R ₂ O ₃	RO ₂ RH ₄	HIGHER GASEOUS HYDROGEN COMPOUNDS RH ₃	HIGHER SALINE OXIDES RO ₃ RH ₂	R ₂ O ₇ RH		RO ₄	

Fig. 3.1 Mendeleev's Periodic Table published earlier

3.3 MODERN PERIODIC LAW AND THE PRESENT FORM OF THE PERIODIC TABLE

We must bear in mind that when Mendeleev developed his **Periodic Table**, chemists knew nothing about the internal structure of atom. However, the beginning of the 20th century witnessed profound developments in theories about sub-atomic particles. In 1913, the English physicist, Henry Moseley observed regularities in the characteristic *X-ray spectra* of the elements. A plot of $\sqrt{\nu}$ (where ν is frequency of X-rays emitted) against atomic number (Z) gave a straight line and not the plot of $\sqrt{\nu}$ vs atomic mass. He thereby showed that the atomic number is a more fundamental property of an element than its atomic mass. **Mendeleev's Periodic Law** was, therefore, accordingly modified. This is known as the **Modern Periodic Law** and can be stated as :

The physical and chemical properties of the elements are periodic functions of their atomic numbers.

The **Periodic Law** revealed important analogies among the 94 naturally occurring elements (neptunium and plutonium like actinium and protoactinium are also found in pitch blende – an ore of uranium). It stimulated renewed interest in Inorganic Chemistry and has carried into the present with the creation of artificially produced short-lived elements.

You may recall that the atomic number is equal to the nuclear charge (*i.e.*, number of protons) or the number of electrons in a neutral atom. It is then easy to visualize the significance of quantum numbers and electronic configurations in periodicity of elements. In fact, it is now recognized that the Periodic Law is essentially the consequence of the periodic variation in electronic configurations, which indeed determine the

physical and chemical properties of elements and their compounds.

Numerous forms of Periodic Table have been devised from time to time. Some forms emphasise chemical reactions and valence, whereas others stress the electronic configuration of elements. A modern version, the so-called “**long form**” of the **Periodic Table** of the elements (Fig. 3.2), is the most convenient and widely used. The horizontal rows (which Mendeleev called **series**) are called **periods** and the vertical columns, **groups**. Elements having similar outer electronic configurations in their atoms are arranged in vertical columns, referred to as **groups** or **families**. According to the recommendation of International Union of Pure and Applied Chemistry (IUPAC), the groups are numbered from 1 to 18 replacing the older notation of groups IA ... VIIA, VIII, IB ... VIIB and 0.

There are altogether seven periods. The period number corresponds to the highest principal quantum number (n) of the elements in the period. The first period contains 2 elements. The subsequent periods consists of 8, 8, 18, 18 and 32 elements, respectively. The seventh period is incomplete and like the sixth period would have a theoretical maximum (on the basis of quantum numbers) of 32 elements. In this form of the Periodic Table, 14 elements of both sixth and seventh periods (lanthanoids and actinoids, respectively) are placed in separate panels at the bottom*.

3.4 NOMENCLATURE OF ELEMENTS WITH ATOMIC NUMBERS > 100

The naming of the new elements had been traditionally the privilege of the discoverer (or discoverers) and the suggested name was ratified by the IUPAC. In recent years this has led to some controversy. The new elements with very high atomic numbers are so unstable that only minute quantities, sometimes only

* Glenn T. Seaborg's work in the middle of the 20th century starting with the discovery of plutonium in 1940, followed by those of all the transuranium elements from 94 to 102 led to reconfiguration of the periodic table placing the actinoids below the lanthanoids. In 1951, Seaborg was awarded the **Nobel Prize** in chemistry for his work. Element 106 has been named Seaborgium (Sg) in his honour.



a few atoms of them are obtained. Their synthesis and characterisation, therefore, require highly sophisticated costly equipment and laboratory. Such work is carried out with competitive spirit only in some laboratories in the world. Scientists, before collecting the reliable data on the new element, at times get tempted to claim for its discovery. For example, both American and Soviet scientists claimed credit for discovering element 104. The Americans named it Rutherfordium whereas Soviets named it Kurchatovium. To avoid such problems, the IUPAC has made recommendation that until a new element's discovery is proved, and its name is officially recognised, a systematic nomenclature be derived directly from the atomic number of the element using the numerical roots for 0 and numbers 1-9. These are shown in Table 3.4. The roots are put together in order of

digits which make up the atomic number and "ium" is added at the end. The IUPAC names for elements with Z above 100 are shown in Table 3.5.

Table 3.4 Notation for IUPAC Nomenclature of Elements

Digit	Name	Abbreviation
0	nil	n
1	un	u
2	bi	b
3	tri	t
4	quad	q
5	pent	p
6	hex	h
7	sept	s
8	oct	o
9	enn	e

Table 3.5 Nomenclature of Elements with Atomic Number Above 100

Atomic Number	Name according to IUPAC nomenclature	Symbol	IUPAC Official Name	IUPAC Symbol
101	Unnilunium	Unu	Mendelevium	Md
102	Unnilbium	Unb	Nobelium	No
103	Unniltrium	Unt	Lawrencium	Lr
104	Unnilquadium	Unq	Rutherfordium	Rf
105	Unnilpentium	Unp	Dubnium	Db
106	Unnilhexium	Unh	Seaborgium	Sg
107	Unnilseptium	Uns	Bohrium	Bh
108	Unniloctium	Uno	Hassium	Hs
109	Unnilennium	Une	Meitnerium	Mt
110	Ununillium	Uun	Darmstadtium	Ds
111	Unununnium	Uuu	Rontgenium	Rg
112	Ununbium	Uub	Copernicium	Cn
113	Ununtrium	Uut	Nihonium	Nh
114	Ununquadium	Uuq	Flerovium	Fl
115	Ununpentium	Uup	Moscovium	Mc
116	Ununhexium	Uuh	Livermorium	Lv
117	Ununseptium	Uus	Tennessine	Ts
118	Ununoctium	Uuo	Oganesson	Og

Thus, the new element first gets a temporary name, with symbol consisting of three letters. Later permanent name and symbol are given by a vote of IUPAC representatives from each country. The permanent name might reflect the country (or state of the country) in which the element was discovered, or pay tribute to a notable scientist. As of now, elements with atomic numbers up to 118 have been discovered. Official names of all elements have been announced by IUPAC.

Problem 3.1

What would be the IUPAC name and symbol for the element with atomic number 120?

Solution

From Table 3.4, the roots for 1, 2 and 0 are un, bi and nil, respectively. Hence, the symbol and the name respectively are Ubn and unbinilium.

3.5 ELECTRONIC CONFIGURATIONS OF ELEMENTS AND THE PERIODIC TABLE

In the preceding unit we have learnt that an electron in an atom is characterised by a set of four quantum numbers, and the principal quantum number (n) defines the main energy level known as **shell**. We have also studied about the filling of electrons into different subshells, also referred to as **orbitals** (s , p , d , f) in an atom. The distribution of electrons into orbitals of an atom is called its **electronic configuration**. An element's location in the Periodic Table reflects the quantum numbers of the last orbital filled. In this section we will observe a direct connection between the electronic configurations of the elements and the long form of the Periodic Table.

(a) Electronic Configurations in Periods

The period indicates the value of n for the outermost or valence shell. In other words, successive period in the Periodic Table is associated with the filling of the next higher principal energy level ($n = 1$, $n = 2$, etc.). It can

be readily seen that the number of elements in each period is twice the number of atomic **orbitals** available in the energy level that is being filled. The first period ($n = 1$) starts with the filling of the lowest level ($1s$) and therefore has two elements — hydrogen ($1s^1$) and helium ($1s^2$) when the first shell (K) is completed. The second period ($n = 2$) starts with lithium and the third electron enters the $2s$ orbital. The next element, beryllium has four electrons and has the electronic configuration $1s^2 2s^2$. Starting from the next element boron, the $2p$ orbitals are filled with electrons when the L shell is completed at neon ($2s^2 2p^6$). Thus there are 8 elements in the second period. The third period ($n = 3$) begins at sodium, and the added electron enters a $3s$ orbital. Successive filling of $3s$ and $3p$ orbitals gives rise to the third period of 8 elements from sodium to argon. The fourth period ($n = 4$) starts at potassium, and the added electrons fill up the $4s$ orbital. Now you may note that before the $4p$ orbital is filled, filling up of $3d$ orbitals becomes energetically favourable and we come across the so called **$3d$ transition series** of elements. This starts from scandium ($Z = 21$) which has the electronic configuration $3d^1 4s^2$. The $3d$ orbitals are filled at zinc ($Z=30$) with electronic configuration $3d^{10} 4s^2$. The fourth period ends at krypton with the filling up of the $4p$ orbitals. Altogether we have 18 elements in this fourth period. The fifth period ($n = 5$) beginning with rubidium is similar to the fourth period and contains the **$4d$ transition series** starting at yttrium ($Z = 39$). This period ends at xenon with the filling up of the $5p$ orbitals. The sixth period ($n = 6$) contains 32 elements and successive electrons enter $6s$, $4f$, $5d$ and $6p$ orbitals, in the order — filling up of the $4f$ orbitals begins with cerium ($Z = 58$) and ends at lutetium ($Z = 71$) to give the **$4f$ -inner transition series** which is called the **lanthanoid series**. The seventh period ($n = 7$) is similar to the sixth period with the successive filling up of the $7s$, $5f$, $6d$ and $7p$ orbitals and includes most of the man-made radioactive elements. This period will end at the element with atomic number 118 which would belong to the noble gas family. Filling up of the $5f$ orbitals after

actinium ($Z = 89$) gives the **5f-inner transition series** known as the **actinoid series**. The **4f** and **5f-inner transition series** of elements are placed separately in the Periodic Table to maintain its structure and to preserve the principle of classification by keeping elements with similar properties in a single column.

Problem 3.2

How would you justify the presence of 18 elements in the 5th period of the Periodic Table?

Solution

When $n = 5$, $l = 0, 1, 2, 3$. The order in which the energy of the available orbitals $4d$, $5s$ and $5p$ increases is $5s < 4d < 5p$. The total number of orbitals available are 9. The maximum number of electrons that can be accommodated is 18; and therefore 18 elements are there in the 5th period.

(b) Groupwise Electronic Configurations

Elements in the same vertical column or group have similar valence shell electronic configurations, the same number of electrons in the outer orbitals, and similar properties. For example, the Group 1 elements (alkali metals) all have ns^1 valence shell electronic configuration as shown below.

Atomic number	Symbol	Electronic configuration
3	Li	$1s^2 2s^1$ (or) $[\text{He}]2s^1$
11	Na	$1s^2 2s^2 2p^6 3s^1$ (or) $[\text{Ne}]3s^1$
19	K	$1s^2 2s^2 2p^6 3s^2 3p^6 4s^1$ (or) $[\text{Ar}]4s^1$
37	Rb	$1s^2 2s^2 2p^6 3s^2 3p^6 3d^{10} 4s^2 4p^6 5s^1$ (or) $[\text{Kr}]5s^1$
55	Cs	$1s^2 2s^2 2p^6 3s^2 3p^6 3d^{10} 4s^2 4p^6 4d^{10} 5s^2 5p^6 6s^1$ (or) $[\text{Xe}]6s^1$
87	Fr	$[\text{Rn}]7s^1$

Thus it can be seen that the properties of an element have periodic dependence upon its atomic number and not on relative atomic mass.

3.6 ELECTRONIC CONFIGURATIONS AND TYPES OF ELEMENTS: S-, P-, D-, F- BLOCKS

The *aufbau* (build up) principle and the electronic configuration of atoms provide

a theoretical foundation for the periodic classification. The elements in a vertical column of the Periodic Table constitute a group or family and exhibit similar chemical behaviour. This similarity arises because these elements have the same number and same distribution of electrons in their outermost orbitals. We can classify the elements into four blocks *viz.*, **s-block**, **p-block**, **d-block** and **f-block** depending on the type of atomic orbitals that are being filled with electrons. This is illustrated in Fig. 3.3. We notice two exceptions to this categorisation. Strictly, helium belongs to the s-block but its positioning in the p-block along with other group 18 elements is justified because it has a completely filled valence shell ($1s^2$) and as a result, exhibits properties characteristic of other noble gases. The other exception is hydrogen. It has only one s-electron and hence can be placed in group 1 (alkali metals). It can also gain an electron to achieve a noble gas arrangement and hence it can behave similar to a group 17 (halogen family) elements. Because it is a special case, we shall place hydrogen separately at the top of the Periodic Table as shown in Fig. 3.2 and Fig. 3.3. We will briefly discuss the salient features of the four types of elements marked in the Periodic Table. More about these elements

will be discussed later. During the description of their features certain terminology has been used which has been classified in section 3.7.

3.6.1 The s-Block Elements

The elements of Group 1 (alkali metals) and Group 2 (alkaline earth metals) which have ns^1 and ns^2 outermost electronic configuration belong to the **s-Block Elements**. They are all

reactive metals with low ionization enthalpies. They lose the outermost electron(s) readily to form 1+ ion (in the case of alkali metals) or 2+ ion (in the case of alkaline earth metals). The metallic character and the reactivity increase as we go down the group. Because of high reactivity they are never found pure in nature. The compounds of the s-block elements, with the exception of those of lithium and beryllium are predominantly ionic.

3.6.2 The p-Block Elements

The **p-Block Elements** comprise those belonging to Group 13 to 18 and these together with the **s-Block Elements** are called the **Representative Elements or Main Group Elements**. The outermost electronic configuration varies from ns^2np^1 to ns^2np^6 in each period. At the end of each period is a noble gas element with a closed valence shell ns^2np^6 configuration. All the orbitals in the valence shell of the **noble gases** are completely filled by electrons and it is very difficult to alter this stable arrangement by the addition or removal of electrons. The noble gases thus exhibit very low chemical reactivity. Preceding the noble gas family are two chemically important groups of non-metals. They are the **halogens** (Group 17) and the **chalcogens** (Group 16). These two groups of elements have highly negative electron gain enthalpies and readily add one or two electrons respectively to attain the stable noble gas configuration. The non-metallic character increases as we move from left to right across a period and metallic character increases as we go down the group.

3.6.3 The d-Block Elements (Transition Elements)

These are the elements of Group 3 to 12 in the centre of the Periodic Table. These are characterised by the filling of inner *d* orbitals by electrons and are therefore referred to as **d-Block Elements**. These elements have the general outer electronic configuration $(n-1)d^{1-10}ns^{0-2}$ except for Pd where its electronic configuration is $4d^{10}5s^0$. They are all metals. They mostly form coloured ions, exhibit variable

valence (oxidation states), paramagnetism and oftenly used as catalysts. However, Zn, Cd and Hg which have the electronic configuration, $(n-1)d^{10}ns^2$ do not show most of the properties of transition elements. In a way, transition metals form a bridge between the chemically active metals of s-block elements and the less active elements of Groups 13 and 14 and thus take their familiar name “**Transition Elements**”.

3.6.4 The f-Block Elements (Inner-Transition Elements)

The two rows of elements at the bottom of the Periodic Table, called the **Lanthanoids**, Ce ($Z = 58$) – Lu ($Z = 71$) and **Actinoids**, Th ($Z = 90$) – Lr ($Z = 103$) are characterised by the outer electronic configuration $(n-2)f^{1-14}(n-1)d^{0-1}ns^2$. The last electron added to each element is filled in *f*-orbital. These two series of elements are hence called the **Inner-Transition Elements (f-Block Elements)**. They are all metals. Within each series, the properties of the elements are quite similar. The chemistry of the early actinoids is more complicated than the corresponding lanthanoids, due to the large number of oxidation states possible for these actinoid elements. Actinoid elements are radioactive. Many of the actinoid elements have been made only in nanogram quantities or even less by nuclear reactions and their chemistry is not fully studied. The elements after uranium are called **Transuranium Elements**.

Problem 3.3

The elements $Z = 117$ and 120 have not yet been discovered. In which family/group would you place these elements and also give the electronic configuration in each case.

Solution

We see from Fig. 3.2, that element with $Z = 117$, would belong to the halogen family (Group 17) and the electronic configuration would be $[Rn] 5f^4 6d^{10} 7s^2 7p^5$. The element with $Z = 120$, will be placed in Group 2 (alkaline earth metals), and will have the electronic configuration $[Uuo] 8s^2$.

3.6.5 Metals, Non-metals and Metalloids

In addition to displaying the classification of elements into **s**-, **p**-, **d**-, and **f**-blocks, Fig. 3.3 shows another broad classification of elements based on their properties. The elements can be divided into **Metals** and **Non-Metals**. Metals comprise more than 78% of all known elements and appear on the left side of the **Periodic Table**. Metals are usually solids at room temperature [mercury is an exception; gallium and caesium also have very low melting points (303K and 302K, respectively)]. Metals usually have high melting and boiling points. They are good conductors of heat and electricity. They are malleable (can be flattened into thin sheets by hammering) and ductile (can be drawn into wires). In contrast, non-metals are located at the top right hand side of the **Periodic Table**. In fact, in a horizontal row, the property of elements change from metallic on the left to non-metallic on the right. Non-metals are usually solids or gases at room temperature with low melting and boiling points (boron and carbon are exceptions). They are poor conductors of heat and electricity. Most non-metallic solids are brittle and are neither malleable nor ductile. The elements become more metallic as we go down a group; the non-metallic character increases as one goes from left to right across the **Periodic Table**. The change from metallic to non-metallic character is not abrupt as shown by the thick zig-zag line in Fig. 3.3. The elements (e.g., silicon, germanium, arsenic, antimony and tellurium) bordering this line and running diagonally across the **Periodic Table** show properties that are characteristic of both metals and non-metals. These elements are called **Semi-metals** or **Metalloids**.

Problem 3.4

Considering the atomic number and position in the periodic table, arrange the following elements in the increasing order of metallic character : Si, Be, Mg, Na, P.

Solution

Metallic character increases down a group and decreases along a period as we move from left to right. Hence the order of increasing metallic character is: P < Si < Be < Mg < Na.

3.7 PERIODIC TRENDS IN PROPERTIES OF ELEMENTS

There are many observable patterns in the physical and chemical properties of elements as we descend in a group or move across a period in the Periodic Table. For example, within a period, chemical reactivity tends to be high in Group 1 metals, lower in elements towards the middle of the table, and increases to a maximum in the Group 17 non-metals. Likewise within a group of representative metals (say alkali metals) reactivity increases on moving down the group, whereas within a group of non-metals (say halogens), reactivity decreases down the group. But why do the properties of elements follow these trends? And how can we explain periodicity? To answer these questions, we must look into the theories of atomic structure and properties of the atom. In this section we shall discuss the periodic trends in certain physical and chemical properties and try to explain them in terms of number of electrons and energy levels.

3.7.1 Trends in Physical Properties

There are numerous physical properties of elements such as melting and boiling points, heats of fusion and vaporization, energy of atomization, etc. which show periodic variations. However, we shall discuss the periodic trends with respect to atomic and ionic radii, ionization enthalpy, electron gain enthalpy and electronegativity.

(a) Atomic Radius

You can very well imagine that finding the size of an atom is a lot more complicated than measuring the radius of a ball. Do you know why? Firstly, because the size of an atom ($\sim 1.2 \text{ \AA}$ i.e., $1.2 \times 10^{-10} \text{ m}$ in radius) is very

small. Secondly, since the electron cloud surrounding the atom does not have a sharp boundary, the determination of the atomic size cannot be precise. In other words, there is no practical way by which the size of an individual atom can be measured. However, an estimate of the atomic size can be made by knowing the distance between the atoms in the combined state. One practical approach to estimate the size of an atom of a non-metallic element is to measure the distance between two atoms when they are bound together by a single bond in a covalent molecule and from this value, the “**Covalent Radius**” of the element can be calculated. For example, the bond distance in the chlorine molecule (Cl_2) is 198 pm and half this distance (99 pm), is taken as the atomic radius of chlorine. For metals, we define the term “**Metallic Radius**” which is taken as half the internuclear distance separating the metal cores in the metallic crystal. For example, the distance between two adjacent copper atoms in solid copper is 256 pm; hence the metallic radius of copper is assigned a value of 128 pm. For simplicity, in this book, we use the term **Atomic Radius** to refer to both covalent or metallic radius depending on whether the element is a non-metal or a metal. Atomic radii can be measured by X-ray or other spectroscopic methods.

The atomic radii of a few elements are listed in Table 3.6. Two trends are obvious. We can explain these trends in terms of nuclear charge and energy level. The atomic size generally decreases across a period as illustrated in Fig. 3.4(a) for the elements of the second period. It is because within the period the outer electrons are in the same valence shell and the effective nuclear charge increases as the atomic number increases resulting in the increased attraction of electrons to the nucleus. Within a family or vertical column of the **periodic table**, the atomic radius increases regularly with atomic number as illustrated in Fig. 3.4(b). For alkali metals and halogens, as we descend the groups, the principal quantum number (n) increases and the valence electrons are farther from the nucleus. This happens because the inner energy levels are filled with electrons, which serve to shield the outer electrons from the pull of the nucleus. Consequently the size of the atom increases as reflected in the atomic radii.

Note that the atomic radii of noble gases are not considered here. Being monoatomic, their (non-bonded radii) values are very large. In fact radii of noble gases should be compared not with the covalent radii but with the van der Waals radii of other elements.

Table 3.6(a) Atomic Radii/pm Across the Periods

Atom (Period II)	Li	Be	B	C	N	O	F
Atomic radius	152	111	88	77	74	66	64
Atom (Period III)	Na	Mg	Al	Si	P	S	Cl
Atomic radius	186	160	143	117	110	104	99

Table 3.6(b) Atomic Radii/pm Down a Family

Atom (Group I)	Atomic Radius	Atom (Group 17)	Atomic Radius
Li	152	F	64
Na	186	Cl	99
K	231	Br	114
Rb	244	I	133
Cs	262	At	140

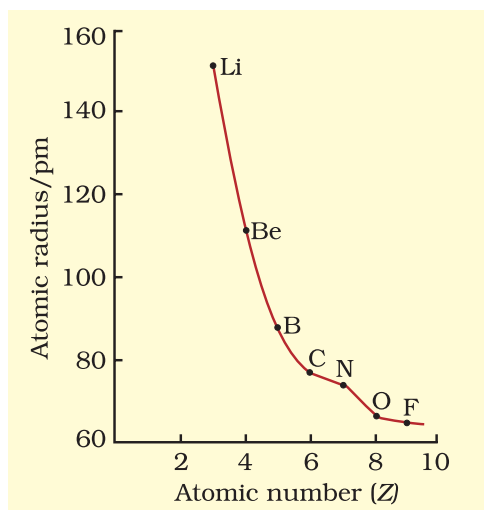

Fig. 3.4 (a) Variation of atomic radius with atomic number across the second period

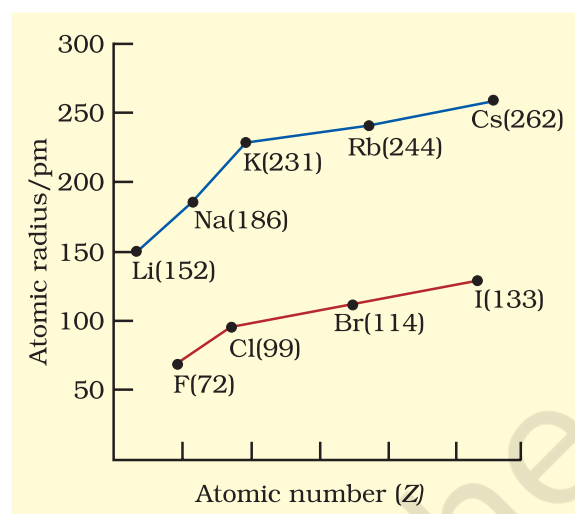

Fig. 3.4 (b) Variation of atomic radius with atomic number for alkali metals and halogens

(b) Ionic Radius

The removal of an electron from an atom results in the formation of a **cation**, whereas gain of an electron leads to an **anion**. The ionic radii can be estimated by measuring the distances between cations and anions in ionic crystals. In general, the ionic radii of elements exhibit the same trend as the atomic radii. A cation is smaller than its parent atom because it has fewer electrons while its nuclear charge remains the same. The size of an anion will be larger than that of the parent atom because the addition of one or more electrons would result in increased repulsion among the electrons and a decrease in effective nuclear charge. For example, the ionic radius of fluoride ion (F^-) is 136 pm whereas the atomic radius of fluorine is only 64 pm. On the other hand, the atomic radius of sodium is 186 pm compared to the ionic radius of 95 pm for Na^+ .

When we find some atoms and ions which contain the same number of electrons, we call them **isoelectronic species***. For example, O^{2-} , F^- , Na^+ and Mg^{2+} have the same number of electrons (10). Their radii would be different because of their different nuclear charges. The

cation with the greater positive charge will have a smaller radius because of the greater attraction of the electrons to the nucleus. Anion with the greater negative charge will have the larger radius. In this case, the net repulsion of the electrons will outweigh the nuclear charge and the ion will expand in size.

Problem 3.5

Which of the following species will have the largest and the smallest size?
Mg, Mg^{2+} , Al, Al^{3+} .

Solution

Atomic radii decrease across a period. Cations are smaller than their parent atoms. Among isoelectronic species, the one with the larger positive nuclear charge will have a smaller radius.

Hence the largest species is Mg; the smallest one is Al^{3+} .

(c) Ionization Enthalpy

A quantitative measure of the tendency of an element to lose electron is given by its **Ionization Enthalpy**. It represents the energy required to remove an electron from an isolated gaseous atom (X) in its ground state.

* Two or more species with same number of atoms, same number of valence electrons and same structure, regardless of the nature of elements involved.

In other words, the first ionization enthalpy for an element X is the enthalpy change ($\Delta_i H$) for the reaction depicted in equation 3.1.



The ionization enthalpy is expressed in units of kJ mol^{-1} . We can define the second ionization enthalpy as the energy required to remove the second most loosely bound electron; it is the energy required to carry out the reaction shown in equation 3.2.



Energy is always required to remove electrons from an atom and hence ionization enthalpies are always positive. The second ionization enthalpy will be higher than the first ionization enthalpy because it is more difficult to remove an electron from a positively charged ion than from a neutral atom. In the same way the third ionization enthalpy will be higher than the second and so on. The term “ionization enthalpy”, if not qualified, is taken as the first ionization enthalpy.

The first ionization enthalpies of elements having atomic numbers up to 60 are plotted in Fig. 3.5. The periodicity of the graph is quite striking. You will find maxima at the noble gases which have closed electron shells and very stable electron configurations. On the other hand, minima occur at the alkali metals and their low ionization enthalpies

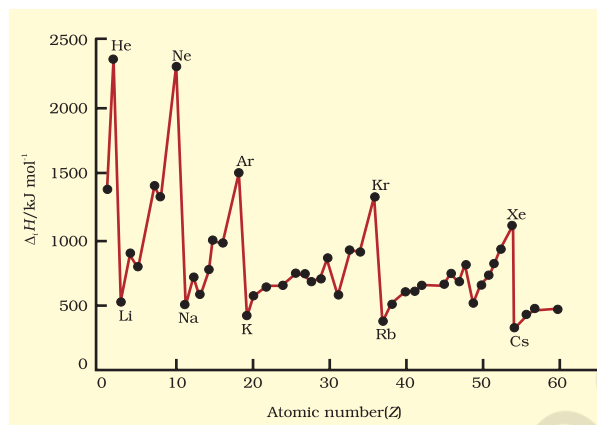
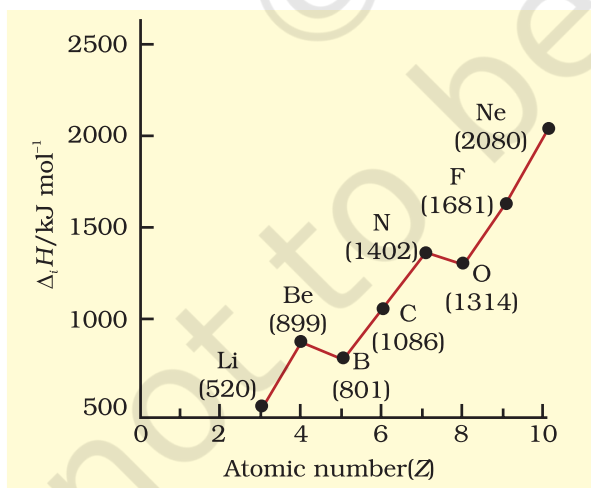
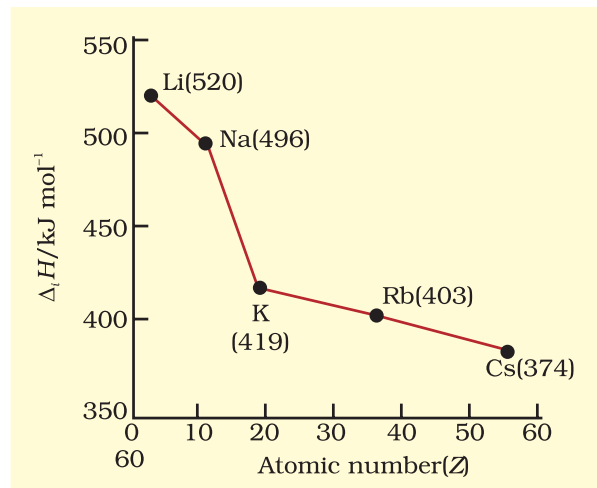

Fig. 3.5 Variation of first ionization enthalpies ($\Delta_i H$) with atomic number for elements with $Z = 1$ to 60

can be correlated with their high reactivity. In addition, you will notice two trends the first ionization enthalpy generally increases as we go across a period and decreases as we descend in a group. These trends are illustrated in Figs. 3.6(a) and 3.6(b) respectively for the elements of the second period and the first group of the periodic table. You will appreciate that the ionization enthalpy and atomic radius are closely related properties. To understand these trends, we have to consider two factors : (i) the attraction of electrons towards the nucleus, and (ii) the repulsion of electrons from each other. The effective nuclear charge experienced by a



3.6 (a)



3.6 (b)

Fig. 3.6(a) First ionization enthalpies ($\Delta_i H$) of elements of the second period as a function of atomic number (Z) and Fig. 3.6(b) $\Delta_i H$ of alkali metals as a function of Z .

valence electron in an atom will be less than the actual charge on the nucleus because of “shielding” or “screening” of the valence electron from the nucleus by the intervening core electrons. For example, the 2s electron in lithium is shielded from the nucleus by the inner core of 1s electrons. As a result, the valence electron experiences a net positive charge which is less than the actual charge of +3. In general, shielding is effective when the orbitals in the inner shells are completely filled. This situation occurs in the case of alkali metals which have single outermost *ns*-electron preceded by a noble gas electronic configuration.

When we move from lithium to fluorine across the second period, successive electrons are added to orbitals in the same principal quantum level and the shielding of the nuclear charge by the inner core of electrons does not increase very much to compensate for the increased attraction of the electron to the nucleus. Thus, across a period, increasing nuclear charge outweighs the shielding. Consequently, the outermost electrons are held more and more tightly and the ionization enthalpy increases across a period. As we go down a group, the outermost electron being increasingly farther from the nucleus, there is an increased shielding of the nuclear charge by the electrons in the inner levels. In this case, increase in shielding outweighs the increasing nuclear charge and the removal of the outermost electron requires less energy down a group.

From Fig. 3.6(a), you will also notice that the first ionization enthalpy of boron ($Z = 5$) is slightly less than that of beryllium ($Z = 4$) even though the former has a greater nuclear charge. When we consider the same principal quantum level, an *s*-electron is attracted to the nucleus more than a *p*-electron. In beryllium, the electron removed during the ionization is an *s*-electron whereas the electron removed during ionization of boron is a *p*-electron. The penetration of a 2s-electron to the nucleus is more than that of a 2*p*-electron; hence the 2*p* electron of boron is more shielded from the nucleus by the inner core of electrons than

the 2s electrons of beryllium. Therefore, it is easier to remove the 2*p*-electron from boron compared to the removal of a 2s-electron from beryllium. Thus, boron has a smaller first ionization enthalpy than beryllium. Another “anomaly” is the smaller first ionization enthalpy of oxygen compared to nitrogen. This arises because in the nitrogen atom, three 2*p*-electrons reside in different atomic orbitals (Hund’s rule) whereas in the oxygen atom, two of the four 2*p*-electrons must occupy the same 2*p*-orbital resulting in an increased electron-electron repulsion. Consequently, it is easier to remove the fourth 2*p*-electron from oxygen than it is, to remove one of the three 2*p*-electrons from nitrogen.

Problem 3.6

The first ionization enthalpy ($\Delta_i H$) values of the third period elements, Na, Mg and Si are respectively 496, 737 and 786 kJ mol⁻¹. Predict whether the first $\Delta_i H$ value for Al will be more close to 575 or 760 kJ mol⁻¹? Justify your answer.

Solution

It will be more close to 575 kJ mol⁻¹. The value for Al should be lower than that of Mg because of effective shielding of 3*p* electrons from the nucleus by 3s-electrons.

(d) Electron Gain Enthalpy

When an electron is added to a neutral gaseous atom (X) to convert it into a negative ion, the enthalpy change accompanying the process is defined as the **Electron Gain Enthalpy** ($\Delta_{eg} H$). Electron gain enthalpy provides a measure of the ease with which an atom adds an electron to form anion as represented by equation 3.3.



Depending on the element, the process of adding an electron to the atom can be either endothermic or exothermic. For many elements energy is released when an electron is added to the atom and the electron gain enthalpy is negative. For example, group 17 elements (the halogens) have very high

Table 3.7 Electron Gain Enthalpies* / (kJ mol⁻¹) of Some Main Group Elements

Group 1	$\Delta_{eg}H$	Group 16	$\Delta_{eg}H$	Group 17	$\Delta_{eg}H$	Group 0	$\Delta_{eg}H$
H	-73					He	+48
Li	-60	O	-141	F	-328	Ne	+116
Na	-53	S	-200	Cl	-349	Ar	+96
K	-48	Se	-195	Br	-325	Kr	+96
Rb	-47	Te	-190	I	-295	Xe	+77
Cs	-46	Po	-174	At	-270	Rn	+68

negative electron gain enthalpies because they can attain stable noble gas electronic configurations by picking up an electron. On the other hand, noble gases have large positive electron gain enthalpies because the electron has to enter the next higher principal quantum level leading to a very unstable electronic configuration. It may be noted that electron gain enthalpies have large negative values toward the upper right of the periodic table preceding the noble gases.

The variation in electron gain enthalpies of elements is less systematic than for ionization enthalpies. As a general rule, electron gain enthalpy becomes more negative with increase in the atomic number across a period. The effective nuclear charge increases from left to right across a period and consequently it will be easier to add an electron to a smaller atom since the added electron on an average would be closer to the positively charged nucleus. We should also expect electron gain enthalpy to become less negative as we go down a group because the size of the atom increases and the added electron would be farther from the nucleus. This is generally the case (Table 3.7). However, electron gain enthalpy of O or F is less negative than that of the succeeding element. This is because when an electron is added to O or F, the added electron goes to the smaller $n = 2$ quantum level and suffers significant repulsion from the other electrons present in this level. For the $n = 3$ quantum level (S or Cl), the added electron occupies a larger region of space and the electron-electron repulsion is much less.

Problem 3.7

Which of the following will have the most negative electron gain enthalpy and which the least negative?

P, S, Cl, F.

Explain your answer.

Solution

Electron gain enthalpy generally becomes more negative across a period as we move from left to right. Within a group, electron gain enthalpy becomes less negative down a group. However, adding an electron to the $2p$ -orbital leads to greater repulsion than adding an electron to the larger $3p$ -orbital. Hence the element with most negative electron gain enthalpy is chlorine; the one with the least negative electron gain enthalpy is phosphorus.

(e) Electronegativity

A qualitative measure of the ability of an atom in a **chemical compound** to attract shared electrons to itself is called **electronegativity**. Unlike ionization enthalpy and electron gain enthalpy, it is not a measurable quantity. However, a number of numerical scales of electronegativity of elements viz., Pauling scale, Mulliken-Jaffe scale, Allred-Rochow scale have been developed. The one which is the most widely used is the Pauling scale. Linus Pauling, an American scientist, in 1922 assigned arbitrarily a value of 4.0 to fluorine, the element considered to have the greatest

* In many books, the negative of the enthalpy change for the process depicted in equation 3.3 is defined as the ELECTRON AFFINITY (A_e) of the atom under consideration. If energy is released when an electron is added to an atom, the electron affinity is taken as positive, contrary to thermodynamic convention. If energy has to be supplied to add an electron to an atom, then the electron affinity of the atom is assigned a negative sign. However, electron affinity is defined as absolute zero and, therefore at any other temperature (T) heat capacities of the reactants and the products have to be taken into account in $\Delta_{eg}H = -A_e - 5/2 RT$.

ability to attract electrons. Approximate values for the electronegativity of a few elements are given in Table 3.8(a)

The electronegativity of any given element is not constant; it varies depending on the element to which it is bound. Though it is not a measurable quantity, it does provide a means of predicting the nature of force that holds a pair of atoms together – a relationship that you will explore later.

Electronegativity generally increases across a period from left to right (say from lithium to fluorine) and decrease down a group (say from fluorine to astatine) in the periodic table. How can these trends be explained? Can the electronegativity be related to atomic radii, which tend to decrease across each period from left to right, but increase down each group? The attraction between the outer (or valence) electrons and the nucleus increases as the atomic radius decreases in a period. The electronegativity also increases.

On the same account electronegativity values decrease with the increase in atomic radii down a group. The trend is similar to that of ionization enthalpy.

Knowing the relationship between electronegativity and atomic radius, can you now visualise the relationship between electronegativity and non-metallic properties? Non-metallic elements have strong tendency

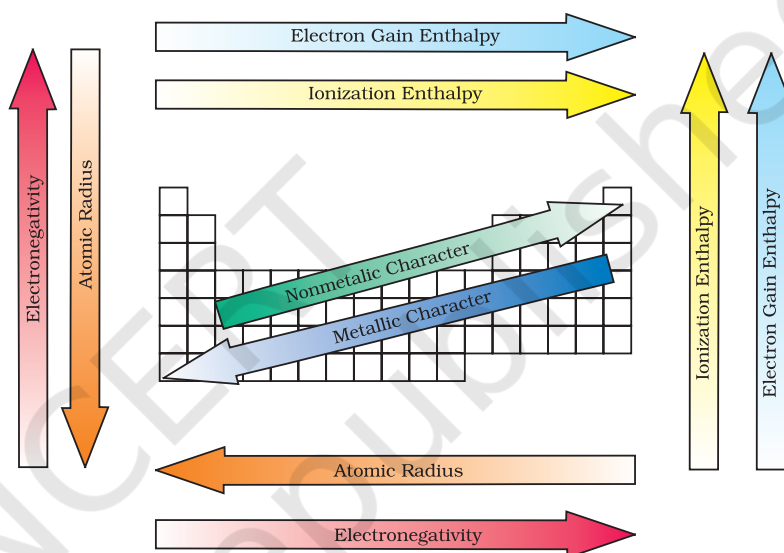

Fig. 3.7 The periodic trends of elements in the periodic table

Table 3.8(a) Electronegativity Values (on Pauling scale) Across the Periods

Atom (Period II)	Li	Be	B	C	N	O	F
Electronegativity	1.0	1.5	2.0	2.5	3.0	3.5	4.0
Atom (Period III)	Na	Mg	Al	Si	P	S	Cl
Electronegativity	0.9	1.2	1.5	1.8	2.1	2.5	3.0

Table 3.8(b) Electronegativity Values (on Pauling scale) Down a Family

Atom (Group I)	Electronegativity Value	Atom (Group 17)	Electronegativity Value
Li	1.0	F	4.0
Na	0.9	Cl	3.0
K	0.8	Br	2.8
Rb	0.8	I	2.5
Cs	0.7	At	2.2

to gain electrons. Therefore, electronegativity is directly related to that non-metallic properties of elements. It can be further extended to say that the electronegativity is inversely related to the metallic properties of elements. Thus, the increase in electronegativities across a period is accompanied by an increase in non-metallic properties (or decrease in metallic properties) of elements. Similarly, the decrease in electronegativity down a group is accompanied by a decrease in non-metallic properties (or increase in metallic properties) of elements.

All these periodic trends are summarised in Figure 3.7.

3.7.2 Periodic Trends in Chemical Properties

Most of the trends in chemical properties of elements, such as diagonal relationships, inert pair effect, effects of lanthanoid contraction etc. will be dealt with along the discussion of each group in later units. In this section we shall study the periodicity of the valence state shown by elements and the anomalous properties of the second period elements (from lithium to fluorine).

(a) Periodicity of Valence or Oxidation States

The valence is the most characteristic property of the elements and can be understood in terms of their electronic configurations. The valence of representative elements is usually (though not necessarily) equal to the number of electrons in the outermost orbitals and/or equal to eight minus the number of outermost electrons as shown below.

Nowadays the term oxidation state is frequently used for valence. Consider the two oxygen containing compounds: OF_2 and Na_2O . The order of electronegativity of the three elements involved in these compounds is $\text{F} > \text{O} > \text{Na}$. Each of the atoms of fluorine,

with outer electronic configuration $2s^2 2p^5$, shares one electron with oxygen in the OF_2 molecule. Being highest electronegative element, fluorine is given oxidation state -1 . Since there are two fluorine atoms in this molecule, oxygen with outer electronic configuration $2s^2 2p^4$ shares two electrons with fluorine atoms and thereby exhibits oxidation state $+2$. In Na_2O , oxygen being more electronegative accepts two electrons, one from each of the two sodium atoms and, thus, shows oxidation state -2 . On the other hand sodium with electronic configuration $3s^1$ loses one electron to oxygen and is given oxidation state $+1$. Thus, the oxidation state of an element in a particular compound can be defined as the charge acquired by its atom on the basis of electronegative consideration from other atoms in the molecule.

Problem 3.8

Using the Periodic Table, predict the formulas of compounds which might be formed by the following pairs of elements; (a) silicon and bromine (b) aluminium and sulphur.

Solution

- (a) Silicon is group 14 element with a valence of 4; bromine belongs to the halogen family with a valence of 1. Hence the formula of the compound formed would be SiBr_4 .
- (b) Aluminium belongs to group 13 with a valence of 3; sulphur belongs to group 16 elements with a valence of 2. Hence, the formula of the compound formed would be Al_2S_3 .

Some periodic trends observed in the valence of elements (hydrides and oxides) are shown in Table 3.9. Other such periodic trends which occur in the chemical behaviour of the elements are discussed elsewhere in

Group	1	2	13	14	15	16	17	18
Number of valence electron	1	2	3	4	5	6	7	8
valence	1	2	3	4	3,5	2,6	1,7	0,8

Table 3.9 Periodic Trends in Valence of Elements as shown by the Formulas of Their Compounds

Group	1	2	13	14	15	16	17
Formula of hydride	LiH NaH KH	CaH ₂	B ₂ H ₆ AlH ₃	CH ₄ SiH ₄ GeH ₄ SnH ₄	NH ₃ PH ₃ AsH ₃	H ₂ O H ₂ S H ₂ Se H ₂ Te	HF HCl HBr HI
Formula of oxide	Li ₂ O Na ₂ O K ₂ O	MgO CaO SrO BaO	B ₂ O ₃ Al ₂ O ₃ Ga ₂ O ₃ In ₂ O ₃	CO ₂ SiO ₂ GeO ₂ SnO ₂ PbO ₂	N ₂ O ₃ , N ₂ O ₅ P ₄ O ₆ , P ₄ O ₁₀ As ₂ O ₃ , As ₂ O ₅ Sb ₂ O ₃ , Sb ₂ O ₅ Bi ₂ O ₃ -	SO ₃ SeO ₃ TeO ₃ -	- Cl ₂ O ₇ - -

this book. There are many elements which exhibit variable valence. This is particularly characteristic of transition elements and actinoids, which we shall study later.

(b) Anomalous Properties of Second Period Elements

The first element of each of the groups 1 (lithium) and 2 (beryllium) and groups 13-17 (boron to fluorine) differs in many respects from the other members of their respective group. For example, lithium unlike other alkali metals, and beryllium unlike other alkaline earth metals, form compounds with pronounced covalent character; the other members of these groups predominantly form ionic compounds. In fact the behaviour of lithium and beryllium is more similar with

the second element of the following group i.e., magnesium and aluminium, respectively. This sort of similarity is commonly referred to as **diagonal relationship** in the periodic properties.

What are the reasons for the different chemical behaviour of the first member of a group of elements in the **s-** and **p-blocks** compared to that of the subsequent members in the same group? The anomalous behaviour is attributed to their small size, large charge/radius ratio and high electronegativity of the elements. In addition, the first member of group has only four valence orbitals (2s and 2p) available for bonding, whereas the second member of the groups have nine valence orbitals (3s, 3p, 3d). As a consequence of this, the maximum covalency of the first member of each group is 4 (e.g., boron can only form [BF₄]⁻, whereas the other members of the groups can expand their valence shell to accommodate more than four pairs of electrons e.g., aluminium [AlF₆]³⁻ forms). Furthermore, the first member of p-block elements displays greater ability to form p_π - p_π multiple bonds to itself (e.g., C = C, C ≡ C, N = N, N ≡ N) and to other second period elements (e.g., C = O, C = N, C ≡ N, N = O) compared to subsequent members of the same group.

Property	Element		
Metallic radius M/pm	Li	Be	B
	152	111	88
	Na	Mg	Al
	186	160	143
Ionic radius M ⁺ /pm	Li	Be	
	76	31	
	Na	Mg	
	102	72	

Problem 3.9

Are the oxidation state and covalency of Al in $[\text{AlCl}(\text{H}_2\text{O})_5]^{2+}$ same ?

Solution

No. The oxidation state of Al is +3 and the covalency is 6.

3.7.3 Periodic Trends and Chemical Reactivity

We have observed the periodic trends in certain fundamental properties such as atomic and ionic radii, ionization enthalpy, electron gain enthalpy and valence. We know by now that the periodicity is related to electronic configuration. That is, all chemical and physical properties are a manifestation of the electronic configuration of elements. We shall now try to explore relationships between these fundamental properties of elements with their chemical reactivity.

The atomic and ionic radii, as we know, generally decrease in a period from left to right. As a consequence, the ionization enthalpies generally increase (with some exceptions as outlined in section 3.7.1(a)) and electron gain enthalpies become more negative across a period. In other words, the ionization enthalpy of the extreme left element in a period is the least and the electron gain enthalpy of the element on the extreme right is the highest negative (note : noble gases having completely filled shells have rather positive electron gain enthalpy values). This results into high chemical reactivity at the two extremes and the lowest in the centre. Thus, the maximum chemical reactivity at the extreme left (among alkali metals) is exhibited by the loss of an electron leading to the formation of a cation and at the extreme right (among halogens) shown by the gain of an electron forming an anion. This property can be related with the reducing and oxidizing behaviour of the elements which you will learn later. However,

here it can be directly related to the metallic and non-metallic character of elements. Thus, the metallic character of an element, which is highest at the extremely left decreases and the non-metallic character increases while moving from left to right across the period. The chemical reactivity of an element can be best shown by its reactions with oxygen and halogens. Here, we shall consider the reaction of the elements with oxygen only. Elements on two extremes of a period easily combine with oxygen to form oxides. The normal oxide formed by the element on extreme left is the most basic (e.g., Na_2O), whereas that formed by the element on extreme right is the most acidic (e.g., Cl_2O_7). Oxides of elements in the centre are amphoteric (e.g., Al_2O_3 , As_2O_3) or neutral (e.g., CO , NO , N_2O). Amphoteric oxides behave as acidic with bases and as basic with acids, whereas neutral oxides have no acidic or basic properties.

Problem 3.10

Show by a chemical reaction with water that Na_2O is a basic oxide and Cl_2O_7 is an acidic oxide.

Solution

Na_2O with water forms a strong base whereas Cl_2O_7 forms strong acid.

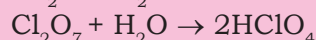
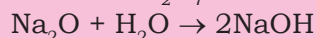

Their basic or acidic nature can be qualitatively tested with litmus paper.

Among transition metals (3d series), the change in atomic radii is much smaller as compared to those of representative elements across the period. The change in atomic radii is still smaller among inner-transition metals (4f series). The ionization enthalpies are intermediate between those of s- and p-blocks. As a consequence, they are less electropositive than group 1 and 2 metals.

In a group, the increase in atomic and ionic radii with increase in atomic number generally results in a gradual decrease in ionization enthalpies and a regular decrease (with exception in some third period elements as shown in section 3.7.1(d)) in electron gain enthalpies in the case of main group elements. Thus, the metallic character

increases down the group and non-metallic character decreases. This trend can be related with their reducing and oxidizing property which you will learn later. In the case of transition elements, however, a reverse trend is observed. This can be explained in terms of atomic size and ionization enthalpy.

SUMMARY

In this Unit, you have studied the development of the **Periodic Law** and the **Periodic Table**. Mendeleev's **Periodic Table** was based on atomic masses. Modern **Periodic Table** arranges the elements in the order of their atomic numbers in seven horizontal rows (**periods**) and eighteen vertical columns (**groups** or **families**). Atomic numbers in a period are consecutive, whereas in a group they increase in a pattern. Elements of the same group have similar **valence shell** electronic configuration and, therefore, exhibit similar chemical properties. However, the elements of the same period have incrementally increasing number of electrons from left to right, and, therefore, have different valencies. Four types of elements can be recognized in the periodic table on the basis of their electronic configurations. These are **s-block**, **p-block**, **d-block** and **f-block** elements. **Hydrogen** with one electron in the 1s orbital occupies a unique position in the periodic table. **Metals** comprise more than seventy eight per cent of the known elements. **Non-metals**, which are located at the top of the periodic table, are less than twenty in number. Elements which lie at the border line between metals and non-metals (e.g., Si, Ge, As) are called **metalloids** or **semi-metals**. Metallic character increases with increasing atomic number in a group whereas decreases from left to right in a period. The physical and chemical properties of elements vary periodically with their atomic numbers.

Periodic trends are observed in **atomic sizes**, **ionization enthalpies**, **electron gain enthalpies**, **electronegativity** and **valence**. The atomic radii decrease while going from left to right in a period and increase with atomic number in a group. Ionization enthalpies generally increase across a period and decrease down a group. Electronegativity also shows a similar trend. Electron gain enthalpies, in general, become more negative across a period and less negative down a group. There is some periodicity in valence, for example, among representative elements, the valence is either equal to the number of electrons in the outermost orbitals or eight minus this number. **Chemical reactivity** is highest at the two extremes of a period and is lowest in the centre. The reactivity on the left extreme of a period is because of the ease of electron loss (or low ionization enthalpy). Highly reactive elements do not occur in nature in free state; they usually occur in the combined form. Oxides formed of the elements on the left are basic and of the elements on the right are acidic in nature. Oxides of elements in the centre are amphoteric or neutral.

EXERCISES

- 3.1 What is the basic theme of organisation in the periodic table?
- 3.2 Which important property did Mendeleev use to classify the elements in his periodic table and did he stick to that?
- 3.3 What is the basic difference in approach between the Mendeleev's Periodic Law and the Modern Periodic Law?
- 3.4 On the basis of quantum numbers, justify that the sixth period of the periodic table should have 32 elements.
- 3.5 In terms of period and group where would you locate the element with $Z=114$?
- 3.6 Write the atomic number of the element present in the third period and seventeenth group of the periodic table.
- 3.7 Which element do you think would have been named by
- Lawrence Berkeley Laboratory
 - Seaborg's group?
- 3.8 Why do elements in the same group have similar physical and chemical properties?
- 3.9 What does atomic radius and ionic radius really mean to you?
- 3.10 How do atomic radius vary in a period and in a group? How do you explain the variation?
- 3.11 What do you understand by isoelectronic species? Name a species that will be isoelectronic with each of the following atoms or ions.
- F^-
 - Ar
 - Mg^{2+}
 - Rb^+
- 3.12 Consider the following species :
- N^{3-} , O^{2-} , F^- , Na^+ , Mg^{2+} and Al^{3+}
- What is common in them?
 - Arrange them in the order of increasing ionic radii.
- 3.13 Explain why cation are smaller and anions larger in radii than their parent atoms?
- 3.14 What is the significance of the terms — 'isolated gaseous atom' and 'ground state' while defining the ionization enthalpy and electron gain enthalpy?
- Hint :** Requirements for comparison purposes.
- 3.15 Energy of an electron in the ground state of the hydrogen atom is $-2.18 \times 10^{-18} J$. Calculate the ionization enthalpy of atomic hydrogen in terms of $J mol^{-1}$.
- Hint:** Apply the idea of mole concept to derive the answer.
- 3.16 Among the second period elements the actual ionization enthalpies are in the order $Li < B < Be < C < O < N < F < Ne$.
- Explain why
- Be has higher $\Delta_i H$ than B
 - O has lower $\Delta_i H$ than N and F?

- 3.17 How would you explain the fact that the first ionization enthalpy of sodium is lower than that of magnesium but its second ionization enthalpy is higher than that of magnesium?
- 3.18 What are the various factors due to which the ionization enthalpy of the main group elements tends to decrease down a group?
- 3.19 The first ionization enthalpy values (in kJ mol^{-1}) of group 13 elements are :
- | | | | | |
|-----|-----|-----|-----|-----|
| B | Al | Ga | In | Tl |
| 801 | 577 | 579 | 558 | 589 |
- How would you explain this deviation from the general trend ?
- 3.20 Which of the following pairs of elements would have a more negative electron gain enthalpy?
(i) O or F (ii) F or Cl
- 3.21 Would you expect the second electron gain enthalpy of O as positive, more negative or less negative than the first? Justify your answer.
- 3.22 What is the basic difference between the terms electron gain enthalpy and electronegativity?
- 3.23 How would you react to the statement that the electronegativity of N on Pauling scale is 3.0 in all the nitrogen compounds?
- 3.24 Describe the theory associated with the radius of an atom as it
(a) gains an electron
(b) loses an electron
- 3.25 Would you expect the first ionization enthalpies for two isotopes of the same element to be the same or different? Justify your answer.
- 3.26 What are the major differences between metals and non-metals?
- 3.27 Use the periodic table to answer the following questions.
(a) Identify an element with five electrons in the outer subshell.
(b) Identify an element that would tend to lose two electrons.
(c) Identify an element that would tend to gain two electrons.
(d) Identify the group having metal, non-metal, liquid as well as gas at the room temperature.
- 3.28 The increasing order of reactivity among group 1 elements is $\text{Li} < \text{Na} < \text{K} < \text{Rb} < \text{Cs}$ whereas that among group 17 elements is $\text{F} > \text{Cl} > \text{Br} > \text{I}$. Explain.
- 3.29 Write the general outer electronic configuration of *s*-, *p*-, *d*- and *f*-block elements.
- 3.30 Assign the position of the element having outer electronic configuration
(i) ns^2np^4 for $n=3$ (ii) $(n-1)d^2ns^2$ for $n=4$, and (iii) $(n-2)f^7(n-1)d^1ns^2$ for $n=6$, in the periodic table.

- 3.31 The first ($\Delta_1 H_1$) and the second ($\Delta_1 H_2$) ionization enthalpies (in kJ mol^{-1}) and the ($\Delta_{eg} H$) electron gain enthalpy (in kJ mol^{-1}) of a few elements are given below:

Elements	ΔH_1	ΔH_2	$\Delta_{eg} H$
I	520	7300	-60
II	419	3051	-48
III	1681	3374	-328
IV	1008	1846	-295
V	2372	5251	+48
VI	738	1451	-40

Which of the above elements is likely to be :

- the least reactive element.
 - the most reactive metal.
 - the most reactive non-metal.
 - the least reactive non-metal.
 - the metal which can form a stable binary halide of the formula MX_2 (X=halogen).
 - the metal which can form a predominantly stable covalent halide of the formula MX (X=halogen)?
- 3.32 Predict the formulas of the stable binary compounds that would be formed by the combination of the following pairs of elements.
- Lithium and oxygen
 - Magnesium and nitrogen
 - Aluminium and iodine
 - Silicon and oxygen
 - Phosphorus and fluorine
 - Element 71 and fluorine
- 3.33 In the modern periodic table, the period indicates the value of :
- atomic number
 - atomic mass
 - principal quantum number
 - azimuthal quantum number.
- 3.34 Which of the following statements related to the modern periodic table is incorrect?
- The *p*-block has 6 columns, because a maximum of 6 electrons can occupy all the orbitals in a *p*-shell.
 - The *d*-block has 8 columns, because a maximum of 8 electrons can occupy all the orbitals in a *d*-subshell.
 - Each block contains a number of columns equal to the number of electrons that can occupy that subshell.
 - The block indicates value of azimuthal quantum number (*l*) for the last subshell that received electrons in building up the electronic configuration.

- 3.35 Anything that influences the valence electrons will affect the chemistry of the element. Which one of the following factors does not affect the valence shell?
- Valence principal quantum number (n)
 - Nuclear charge (Z)
 - Nuclear mass
 - Number of core electrons.
- 3.36 The size of isoelectronic species — F^- , Ne and Na^+ is affected by
- nuclear charge (Z)
 - valence principal quantum number (n)
 - electron-electron interaction in the outer orbitals
 - none of the factors because their size is the same.
- 3.37 Which one of the following statements is incorrect in relation to ionization enthalpy?
- Ionization enthalpy increases for each successive electron.
 - The greatest increase in ionization enthalpy is experienced on removal of electron from core noble gas configuration.
 - End of valence electrons is marked by a big jump in ionization enthalpy.
 - Removal of electron from orbitals bearing lower n value is easier than from orbital having higher n value.
- 3.38 Considering the elements B, Al, Mg, and K, the correct order of their metallic character is :
- $B > Al > Mg > K$
 - $Al > Mg > B > K$
 - $Mg > Al > K > B$
 - $K > Mg > Al > B$
- 3.39 Considering the elements B, C, N, F, and Si, the correct order of their non-metallic character is :
- $B > C > Si > N > F$
 - $Si > C > B > N > F$
 - $F > N > C > B > Si$
 - $F > N > C > Si > B$
- 3.40 Considering the elements F, Cl, O and N, the correct order of their chemical reactivity in terms of oxidizing property is :
- $F > Cl > O > N$
 - $F > O > Cl > N$
 - $Cl > F > O > N$
 - $O > F > N > Cl$



11082CH04

UNIT 4

CHEMICAL BONDING AND MOLECULAR STRUCTURE

Objectives

After studying this Unit, you will be able to

- understand Kössel-Lewis approach to chemical bonding;
- explain the octet rule and its limitations, draw Lewis structures of simple molecules;
- explain the formation of different types of bonds;
- describe the VSEPR theory and predict the geometry of simple molecules;
- explain the valence bond approach for the formation of covalent bonds;
- predict the directional properties of covalent bonds;
- explain the different types of hybridisation involving *s*, *p* and *d* orbitals and draw shapes of simple covalent molecules;
- describe the molecular orbital theory of homonuclear diatomic molecules;
- explain the concept of hydrogen bond.

“*Scientists are constantly discovering new compounds, orderly arranging the facts about them, trying to explain with the existing knowledge, organising to modify the earlier views or evolve theories for explaining the newly observed facts.*”

Matter is made up of one or different type of elements. Under normal conditions no other element exists as an independent atom in nature, except noble gases. However, a group of atoms is found to exist together as one species having characteristic properties. Such a group of atoms is called a molecule. Obviously there must be some force which holds these constituent atoms together in the molecules. **The attractive force which holds various constituents (atoms, ions, etc.) together in different chemical species is called a chemical bond.** Since the formation of chemical compounds takes place as a result of combination of atoms of various elements in different ways, it raises many questions. Why do atoms combine? Why are only certain combinations possible? Why do some atoms combine while certain others do not? Why do molecules possess definite shapes? To answer such questions different theories and concepts have been put forward from time to time. These are Kössel-Lewis approach, Valence Shell Electron Pair Repulsion (VSEPR) Theory, Valence Bond (VB) Theory and Molecular Orbital (MO) Theory. The evolution of various theories of valence and the interpretation of the nature of chemical bonds have closely been related to the developments in the understanding of the structure of atom, the electronic configuration of elements and the periodic table. Every system tends to be more stable and bonding is nature's way of lowering the energy of the system to attain stability.

4.1 KÖSSEL-LEWIS APPROACH TO CHEMICAL BONDING

In order to explain the formation of chemical bond in terms of electrons, a number of attempts were made, but it was only in 1916 when Kössel and Lewis succeeded independently in giving a satisfactory explanation. They were the first to provide some logical explanation of valence which was based on the inertness of noble gases.

Lewis pictured the atom in terms of a positively charged 'Kernel' (the nucleus plus the inner electrons) and the outer shell that could accommodate a maximum of eight electrons. He, further assumed that these eight electrons occupy the corners of a cube which surround the 'Kernel'. Thus the single outer shell electron of sodium would occupy one corner of the cube, while in the case of a noble gas all the eight corners would be occupied. This octet of electrons, represents a particularly stable electronic arrangement.

Lewis postulated that atoms achieve the stable octet when they are linked by chemical bonds. In the case of sodium and chlorine, this can happen by the transfer of an electron from sodium to chlorine thereby giving the Na^+ and Cl^- ions. In the case of other molecules like Cl_2 , H_2 , F_2 , etc., the bond is formed by the sharing of a pair of electrons between the atoms. In the process each atom attains a **stable outer octet of electrons.**

Lewis Symbols: In the formation of a molecule, only the outer shell electrons take part in chemical combination and they are known as **valence electrons**. The inner shell electrons are well protected and are generally not involved in the combination process. G.N. Lewis, an American chemist introduced simple notations to represent valence electrons in an atom. These notations are called **Lewis symbols**. For example, the Lewis symbols for the elements of second period are as under:

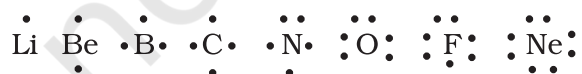

Significance of Lewis Symbols : The number of dots around the symbol represents

the number of valence electrons. This number of valence electrons helps to calculate the common or **group valence** of the element. The group valence of the elements is generally either equal to the number of dots in Lewis symbols or 8 minus the number of dots or valence electrons.

Kössel, in relation to chemical bonding, drew attention to the following facts:

- In the periodic table, the highly electronegative halogens and the highly electropositive alkali metals are separated by the noble gases;
- The formation of a negative ion from a halogen atom and a positive ion from an alkali metal atom is associated with the gain and loss of an electron by the respective atoms;
- The negative and positive ions thus formed attain stable noble gas electronic configurations. The noble gases (with the exception of helium which has a duplet of electrons) have a particularly stable outer shell configuration of eight (octet) electrons, ns^2np^6 .
- The negative and positive ions are stabilized by electrostatic attraction.

For example, the formation of NaCl from sodium and chlorine, according to the above scheme, can be explained as:

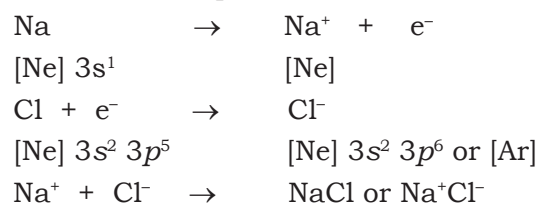

Similarly the formation of CaF_2 may be shown as:

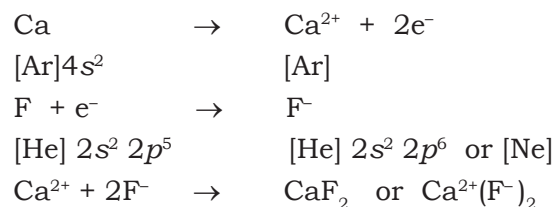

The bond formed, as a result of the electrostatic attraction between the positive and negative ions was termed as

the electrovalent bond. The electrovalence is thus equal to the number of unit charge(s) on the ion. Thus, calcium is assigned a positive electrovalence of two, while chlorine a negative electrovalence of one.

Kössel's postulations provide the basis for the modern concepts regarding ion-formation by electron transfer and the formation of ionic crystalline compounds. His views have proved to be of great value in the understanding and systematisation of the ionic compounds. At the same time he did recognise the fact that a large number of compounds did not fit into these concepts.

4.1.1 Octet Rule

Kössel and Lewis in 1916 developed an important theory of chemical combination between atoms known as **electronic theory of chemical bonding**. According to this, atoms can combine either by transfer of valence electrons from one atom to another (gaining or losing) or by sharing of valence electrons in order to have an octet in their valence shells. This is known as **octet rule**.

4.1.2 Covalent Bond

Langmuir (1919) refined the Lewis postulations by abandoning the idea of the stationary cubical arrangement of the octet, and by introducing the term **covalent bond**. The Lewis-Langmuir theory can be understood by considering the formation of the chlorine molecule, Cl_2 . The Cl atom with electronic configuration, $[\text{Ne}]3s^2 3p^5$, is one electron short of the argon configuration. The formation of the Cl_2 molecule can be understood in terms of the sharing of a pair of electrons between the two chlorine atoms, each chlorine atom contributing one electron to the shared pair. In the process both

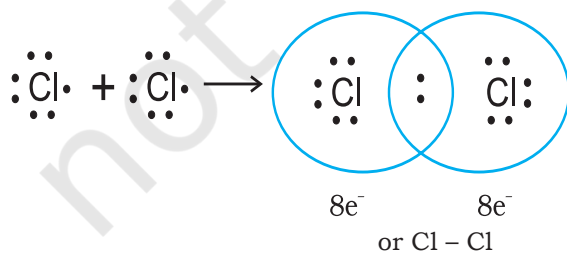

Covalent bond between two Cl atoms

chlorine atoms attain the outer shell octet of the nearest noble gas (i.e., argon).

The dots represent electrons. Such structures are referred to as Lewis dot structures.

The Lewis dot structures can be written for other molecules also, in which the combining atoms may be identical or different. The important conditions being that:

- Each bond is formed as a result of sharing of an electron pair between the atoms.
- Each combining atom contributes at least one electron to the shared pair.
- The combining atoms attain the outer-shell noble gas configurations as a result of the sharing of electrons.
- Thus in water and carbon tetrachloride molecules, formation of covalent bonds can be represented as:

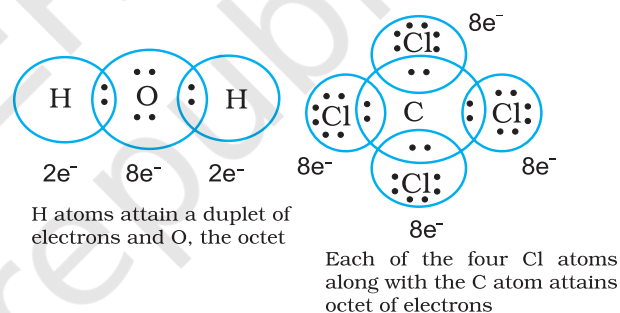

Thus, when two atoms share one electron pair they are said to be joined by a single covalent bond. In many compounds we have **multiple bonds** between atoms. The formation of multiple bonds envisages sharing of more than one electron pair between two atoms. **If two atoms share two pairs of electrons, the covalent bond between them is called a double bond.** For example, in the carbon dioxide molecule, we have two double bonds between the carbon and oxygen atoms. Similarly in ethene molecule the two carbon atoms are joined by a double bond.

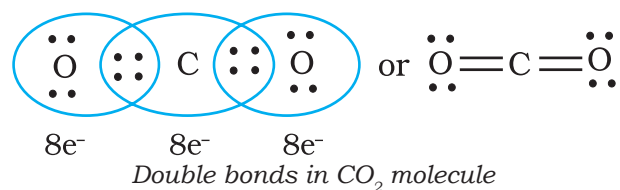

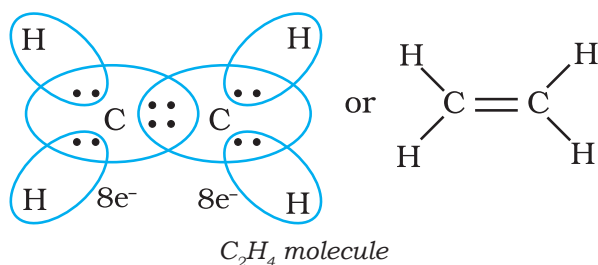

When combining atoms share three electron pairs as in the case of two nitrogen atoms in the N_2 molecule and the two carbon atoms in the ethyne molecule, a triple bond is formed.

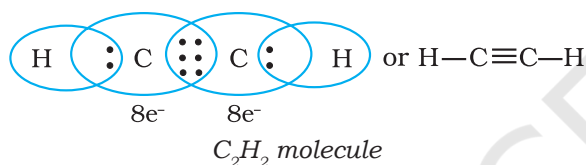
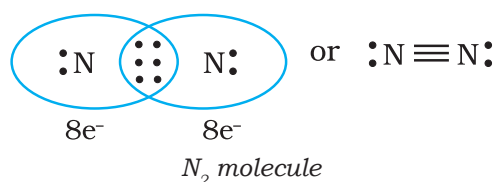

4.1.3 Lewis Representation of Simple Molecules (the Lewis Structures)

The Lewis dot structures provide a picture of bonding in molecules and ions in terms of the shared pairs of electrons and the octet rule. While such a picture may not explain the bonding and behaviour of a molecule completely, it does help in understanding the formation and properties of a molecule to a large extent. Writing of Lewis dot structures of molecules is, therefore, very useful. The Lewis dot structures can be written by adopting the following steps:

- The total number of electrons required for writing the structures are obtained by adding the valence electrons of the combining atoms. For example, in the CH_4 molecule there are eight valence electrons available for bonding (4 from carbon and 4 from the four hydrogen atoms).
- For anions, each negative charge would mean addition of one electron. For cations, each positive charge would result in subtraction of one electron from the total

number of valence electrons. For example, for the CO_3^{2-} ion, the two negative charges indicate that there are two additional electrons than those provided by the neutral atoms. For NH_4^+ ion, one positive charge indicates the loss of one electron from the group of neutral atoms.

- Knowing the chemical symbols of the combining atoms and having knowledge of the skeletal structure of the compound (known or guessed intelligently), it is easy to distribute the total number of electrons as bonding shared pairs between the atoms in proportion to the total bonds.
- In general the least electronegative atom occupies the central position in the molecule/ion. For example in the NF_3 and CO_3^{2-} , nitrogen and carbon are the central atoms whereas fluorine and oxygen occupy the terminal positions.
- After accounting for the shared pairs of electrons for single bonds, the remaining electron pairs are either utilized for multiple bonding or remain as the lone pairs. The basic requirement being that each bonded atom gets an octet of electrons.

Lewis representations of a few molecules/ions are given in Table 4.1.

Table 4.1 The Lewis Representation of Some Molecules

Molecule/Ion	Lewis Representation	
H_2	$H : H^*$	$H - H$
O_2	$:\ddot{O}::\ddot{O}:$	$:\ddot{O}=\ddot{O}:$
O_3	$\begin{array}{c} \cdot\ddot{O}^+ \\ \cdot\ddot{O}::\ddot{O}^- \end{array}$	$\begin{array}{c} \cdot\ddot{O}^+ \\ \cdot\ddot{O}::\ddot{O}^- \end{array}$
NF_3	$\begin{array}{c} \cdot\ddot{F}::\ddot{N}::\ddot{F} \\ \cdot\ddot{F} \end{array}$	$\begin{array}{c} \cdot\ddot{F}::\ddot{N}::\ddot{F} \\ \cdot\ddot{F} \end{array}$
CO_3^{2-}	$\left[\begin{array}{c} \cdot\ddot{O}::\ddot{O} \\ \cdot\ddot{O}::\ddot{C}::\ddot{O} \end{array} \right]^{2-}$	$\left[\begin{array}{c} \cdot\ddot{O}::\ddot{O} \\ \cdot\ddot{O}::\ddot{C}::\ddot{O} \end{array} \right]^{2-}$
HNO_3	$\begin{array}{c} \cdot\ddot{O}::\ddot{N}^+::\ddot{O}::\ddot{O}^- \\ \cdot\ddot{O}^- \end{array} H$	$\begin{array}{c} \cdot\ddot{O}::\ddot{N}^+::\ddot{O}::\ddot{O}^- \\ \cdot\ddot{O}^- \end{array} H$

* Each H atom attains the configuration of helium (a duplet of electrons)

Problem 4.1

Write the Lewis dot structure of CO molecule.

Solution

Step 1. Count the total number of valence electrons of carbon and oxygen atoms. The outer (valence) shell configurations of carbon and oxygen atoms are: $2s^2 2p^2$ and $2s^2 2p^4$, respectively. The valence electrons available are $4 + 6 = 10$.

Step 2. The skeletal structure of CO is written as: C O

Step 3. Draw a single bond (one shared electron pair) between C and O and complete the octet on O, the remaining two electrons are the lone pair on C.

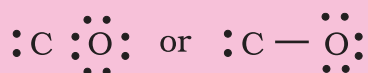

This does not complete the octet on carbon and hence we have to resort to multiple bonding (in this case a triple bond) between C and O atoms. This satisfies the octet rule condition for both atoms.

**Problem 4.2**

Write the Lewis structure of the nitrite ion, NO_2^- .

Solution

Step 1. Count the total number of valence electrons of the nitrogen atom, the oxygen atoms and the additional one negative charge (equal to one electron).



$$5 + (2 \times 6) + 1 = 18 \text{ electrons}$$

Step 2. The skeletal structure of NO_2^- is written as: O N O

Step 3. Draw a single bond (one shared electron pair) between the nitrogen and

each of the oxygen atoms completing the octets on oxygen atoms. This, however, does not complete the octet on nitrogen if the remaining two electrons constitute lone pair on it.

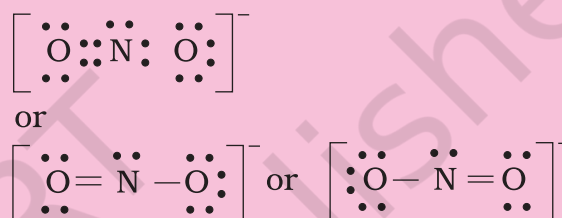

Hence we have to resort to multiple bonding between nitrogen and one of the oxygen atoms (in this case a double bond). This leads to the following Lewis dot structures.

**4.1.4 Formal Charge**

Lewis dot structures, in general, do not represent the actual shapes of the molecules. In case of polyatomic ions, the net charge is possessed by the ion as a whole and not by a particular atom. It is, however, feasible to assign a formal charge on each atom. The formal charge of an atom in a polyatomic molecule or ion may be defined as the difference between the number of valence electrons of that atom in an isolated or free state and the number of electrons assigned to that atom in the Lewis structure. It is expressed as :

Formal charge (F.C.)
on an atom in a Lewis
structure =

$$\left[\begin{array}{c} \text{total number of valence} \\ \text{electrons in the free} \\ \text{atom} \end{array} \right] - \left[\begin{array}{c} \text{total number of non} \\ \text{bonding (lone pair)} \\ \text{electrons} \end{array} \right] - (1/2) \left[\begin{array}{c} \text{total number of} \\ \text{bonding (shared)} \\ \text{electrons} \end{array} \right]$$

The counting is based on the assumption that the atom in the molecule owns one electron of each shared pair and both the electrons of a lone pair.

Let us consider the ozone molecule (O_3). The Lewis structure of O_3 may be drawn as:

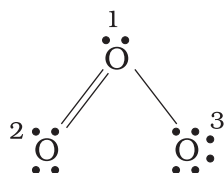

The atoms have been numbered as 1, 2 and 3. The formal charge on:

- The central O atom marked 1

$$= 6 - 2 - \frac{1}{2}(6) = +1$$

- The end O atom marked 2

$$= 6 - 4 - \frac{1}{2}(4) = 0$$

- The end O atom marked 3

$$= 6 - 6 - \frac{1}{2}(2) = -1$$

Hence, we represent O_3 along with the formal charges as follows:

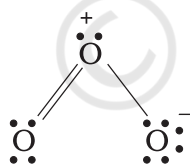

We must understand that formal charges do not indicate real charge separation within the molecule. Indicating the charges on the atoms in the Lewis structure only helps in keeping track of the valence electrons in the molecule. Formal charges help in the selection of the lowest energy structure from a number of possible Lewis structures for a given species. **Generally the lowest energy structure is the one with the smallest formal charges on the atoms. The formal charge is a factor based on a pure covalent view of bonding in which electron pairs are shared equally by neighbouring atoms.**

4.1.5 Limitations of the Octet Rule

The octet rule, though useful, is not universal. It is quite useful for understanding the structures of most of the organic compounds and it applies mainly to the second period elements of the periodic table. There are three types of exceptions to the octet rule.

The incomplete octet of the central atom

In some compounds, the number of electrons surrounding the central atom is less than eight. This is especially the case with elements having less than four valence electrons. Examples are $LiCl$, BeH_2 and BCl_3 .



Li , Be and B have 1, 2 and 3 valence electrons only. Some other such compounds are $AlCl_3$ and BF_3 .

Odd-electron molecules

In molecules with an odd number of electrons like nitric oxide, NO and nitrogen dioxide, NO_2 , the octet rule is not satisfied for all the atoms



The expanded octet

Elements in and beyond the third period of the periodic table have, apart from $3s$ and $3p$ orbitals, $3d$ orbitals also available for bonding. In a number of compounds of these elements there are more than eight valence electrons around the central atom. This is termed as the expanded octet. Obviously the octet rule does not apply in such cases.

Some of the examples of such compounds are: PF_5 , SF_6 , H_2SO_4 and a number of coordination compounds.

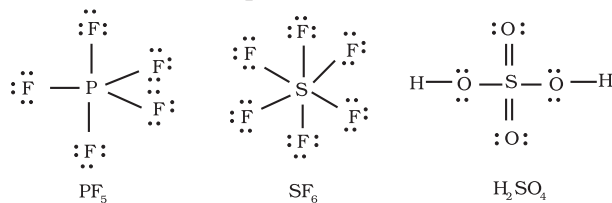

10 electrons around the P atom

12 electrons around the S atom

12 electrons around the S atom

Interestingly, sulphur also forms many compounds in which the octet rule is obeyed. In sulphur dichloride, the S atom has an octet of electrons around it.

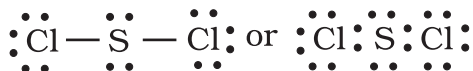

Other drawbacks of the octet theory

- It is clear that octet rule is based upon the chemical inertness of noble gases. However, some noble gases (for example xenon and krypton) also combine with oxygen and fluorine to form a number of compounds like XeF_2 , KrF_2 , XeOF_2 etc.
- This theory does not account for the shape of molecules.
- It does not explain the relative stability of the molecules being totally silent about the energy of a molecule.

4.2 IONIC OR ELECTROVALENT BOND

From the Kössel and Lewis treatment of the formation of an ionic bond, it follows that the formation of ionic compounds would primarily depend upon:

- The ease of formation of the positive and negative ions from the respective neutral atoms;
- The arrangement of the positive and negative ions in the solid, that is, the lattice of the crystalline compound.

The formation of a positive ion involves ionization, i.e., removal of electron(s) from the neutral atom and that of the negative ion involves the addition of electron(s) to the neutral atom.

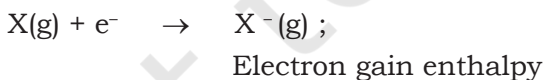
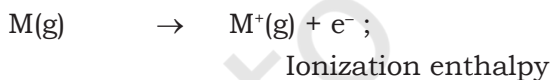

The **electron gain enthalpy**, $\Delta_{eg}H$, is the enthalpy change (Unit 3), when a gas phase atom in its ground state gains an electron. The electron gain process may be exothermic or endothermic. The ionization, on the other hand, is always endothermic. Electron

affinity, is the negative of the energy change accompanying electron gain.

Obviously ionic bonds will be formed more easily between elements with comparatively low ionization enthalpies and elements with comparatively high negative value of electron gain enthalpy.

Most ionic compounds have cations derived from metallic elements and anions from non-metallic elements. The ammonium ion, NH_4^+ (made up of two non-metallic elements) is an exception. It forms the cation of a number of ionic compounds.

Ionic compounds in the crystalline state consist of orderly three-dimensional arrangements of cations and anions held together by coulombic interaction energies. These compounds crystallise in different crystal structures determined by the size of the ions, their packing arrangements and other factors. The crystal structure of sodium chloride, NaCl (rock salt), for example is shown below.

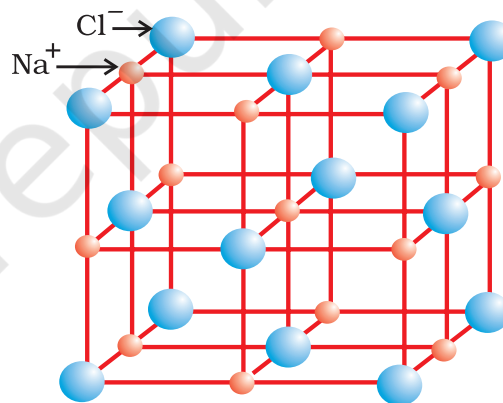

Rock salt structure

In ionic solids, the sum of the electron gain enthalpy and the ionization enthalpy may be positive but still the crystal structure gets stabilized due to the energy released in the formation of the crystal lattice. For example: the ionization enthalpy for $\text{Na}^+(\text{g})$ formation from Na(g) is $495.8 \text{ kJ mol}^{-1}$; while the electron gain enthalpy for the change $\text{Cl(g)} + \text{e}^- \rightarrow \text{Cl}^-(\text{g})$ is, $-348.7 \text{ kJ mol}^{-1}$ only. The sum of the two, $147.1 \text{ kJ mol}^{-1}$ is more than compensated for by the enthalpy of lattice formation of NaCl(s) (-788 kJ mol^{-1}). Therefore, the energy released in the processes is more than the

energy absorbed. **Thus a qualitative measure of the stability of an ionic compound is provided by its enthalpy of lattice formation and not simply by achieving octet of electrons around the ionic species in gaseous state.**

Since lattice enthalpy plays a key role in the formation of ionic compounds, it is important that we learn more about it.

4.2.1 Lattice Enthalpy

The Lattice Enthalpy of an ionic solid is defined as the energy required to completely separate one mole of a solid ionic compound into gaseous constituent ions. For example, the lattice enthalpy of NaCl is 788 kJ mol^{-1} . This means that 788 kJ of energy is required to separate one mole of solid NaCl into one mole of Na^+ (g) and one mole of Cl^- (g) to an infinite distance.

This process involves both the attractive forces between ions of opposite charges and the repulsive forces between ions of like charge. The solid crystal being three-dimensional; it is not possible to calculate lattice enthalpy directly from the interaction of forces of attraction and repulsion only. Factors associated with the crystal geometry have to be included.

4.3 BOND PARAMETERS

4.3.1 Bond Length

Bond length is defined as the equilibrium distance between the nuclei of two bonded atoms in a molecule. Bond lengths are measured by spectroscopic, X-ray diffraction and electron-diffraction techniques about which you will learn in higher classes. Each atom of the bonded pair contributes to the bond length (Fig. 4.1). In the case of a covalent bond, the contribution from each atom is called the covalent radius of that atom.

The covalent radius is measured approximately as the radius of an atom's core which is in contact with the core of an adjacent atom in a bonded situation. The covalent radius is half of the distance between two similar atoms joined by a covalent bond

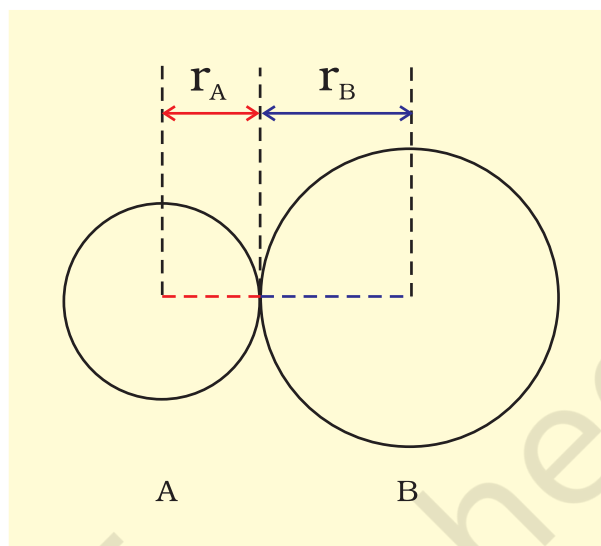

Fig. 4.1 The bond length in a covalent molecule AB.

$R = r_A + r_B$ (R is the bond length and r_A and r_B are the covalent radii of atoms A and B respectively)

in the same molecule. **The van der Waals radius represents the overall size of the atom which includes its valence shell in a nonbonded situation.** Further, the van der Waals radius is half of the distance between two similar atoms in separate molecules in a solid. Covalent and van der Waals radii of chlorine are depicted in Fig. 4.2.

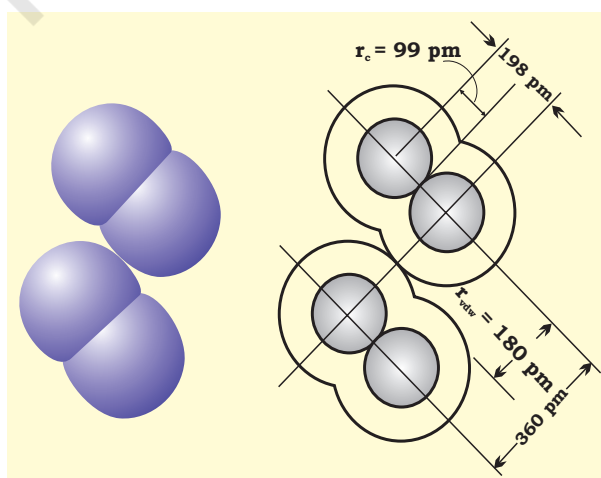

Fig. 4.2 Covalent and van der Waals radii in a chlorine molecule. The inner circles correspond to the size of the chlorine atom (r_{vdw} and r_c are van der Waals and covalent radii respectively).

Some typical average bond lengths for single, double and triple bonds are shown in Table 4.2. Bond lengths for some common molecules are given in Table 4.3.

The covalent radii of some common elements are listed in Table 4.4.

4.3.2 Bond Angle

It is defined as the angle between the orbitals containing bonding electron pairs around the central atom in a molecule/complex ion. Bond angle is expressed in degree which can be experimentally determined by spectroscopic methods. It gives some idea regarding the distribution of orbitals around the central atom in a molecule/complex ion and hence it helps us in determining its shape. For example H–O–H bond angle in water can be represented as under :

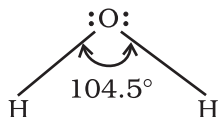

4.3.3 Bond Enthalpy

It is defined as the amount of energy required to break one mole of bonds of a particular type between two atoms in a gaseous state. The unit of bond enthalpy is kJ mol^{-1} . For example, the H–H bond enthalpy in hydrogen molecule is $435.8 \text{ kJ mol}^{-1}$.



Similarly the bond enthalpy for molecules containing multiple bonds, for example O_2 and N_2 will be as under :

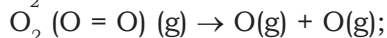

$$\Delta_a H^\ominus = 498 \text{ kJ mol}^{-1}$$

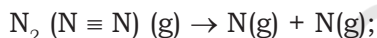

$$\Delta_a H^\ominus = 946.0 \text{ kJ mol}^{-1}$$

It is important that larger the bond dissociation enthalpy, stronger will be the bond in the molecule. For a heteronuclear diatomic molecules like HCl, we have

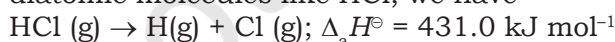

In case of polyatomic molecules, the measurement of bond strength is more complicated. For example in case of H_2O molecule, the enthalpy needed to break the two O–H bonds is not the same.

Table 4.2 Average Bond Lengths for Some Single, Double and Triple Bonds

Bond Type	Covalent Bond Length (pm)
O–H	96
C–H	107
N–O	136
C–O	143
C–N	143
C–C	154
C=O	121
N=O	122
C=C	133
C=N	138
C≡N	116
C≡C	120

Table 4.3 Bond Lengths in Some Common Molecules

Molecule	Bond Length (pm)
H_2 (H – H)	74
F_2 (F – F)	144
Cl_2 (Cl – Cl)	199
Br_2 (Br – Br)	228
I_2 (I – I)	267
N_2 (N ≡ N)	109
O_2 (O = O)	121
HF (H – F)	92
HCl (H – Cl)	127
HBr (H – Br)	141
HI (H – I)	160

Table 4.4 Covalent Radii, r_{cov}^* /(pm)

H	37						
C	77(1)	N	74 (1)	O	66(1)	F	64
	67 (2)		65(2)		57 (2)	Cl	99
	60(3)		55(3)				
		P	110	S	104(1)	Br	114
					95(2)		
		As	121	Se	104	I	133
		Sb	141	Te	137		

* The values cited are for single bonds, except where otherwise indicated in parenthesis. (See also Unit 3 for periodic trends).

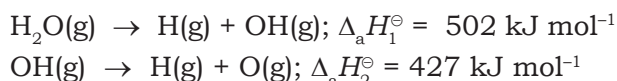

The difference in the $\Delta_a H^\ominus$ value shows that the second O – H bond undergoes some change because of changed chemical environment. This is the reason for some difference in energy of the same O – H bond in different molecules like $\text{C}_2\text{H}_5\text{OH}$ (ethanol) and water. Therefore in polyatomic molecules the term **mean or average bond enthalpy** is used. It is obtained by dividing total bond dissociation enthalpy by the number of bonds broken as explained below in case of water molecule,

$$\begin{aligned} \text{Average bond enthalpy} &= \frac{502 + 427}{2} \\ &= 464.5 \text{ kJ mol}^{-1} \end{aligned}$$

4.3.4 Bond Order

In the Lewis description of covalent bond, the Bond Order is given by the number of bonds between the two atoms in a molecule. The bond order, for example in H_2 (with a single shared electron pair), in O_2 (with two shared electron pairs) and in N_2 (with three shared electron pairs) is 1,2,3 respectively. Similarly in CO (three shared electron pairs between C and O) the bond order is 3. For N_2 , bond order is 3 and its $\Delta_a H^\ominus$ is 946 kJ mol^{-1} ; being one of the highest for a diatomic molecule.

Isoelectronic molecules and ions have identical bond orders; for example, F_2 and O_2^{2-} have bond order 1. N_2 , CO and NO^+ have bond order 3.

A general correlation useful for understanding the stabilities of molecules is that: with increase in bond order, bond enthalpy increases and bond length decreases.

4.3.5 Resonance Structures

It is often observed that a single Lewis structure is inadequate for the representation of a molecule in conformity with its experimentally determined parameters. For example, the ozone, O_3 molecule can be equally represented by the structures I and II shown below:

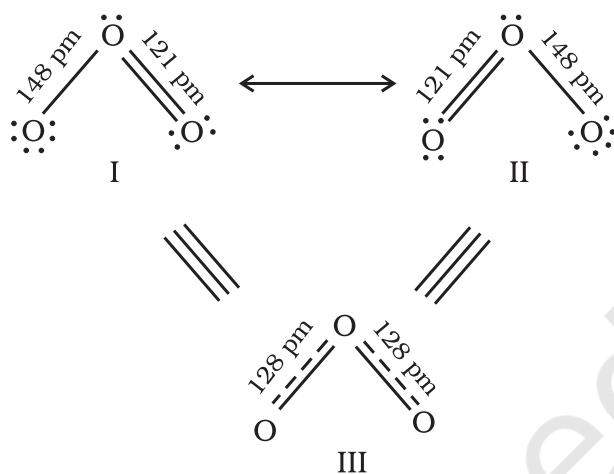

Fig. 4.3 Resonance in the O_3 molecule

(structures I and II represent the two canonical forms while the structure III is the resonance hybrid)

In both structures we have a O–O single bond and a O=O double bond. The normal O–O and O=O bond lengths are 148 pm and 121 pm respectively. Experimentally determined oxygen-oxygen bond lengths in the O_3 molecule are same (128 pm). Thus the oxygen-oxygen bonds in the O_3 molecule are intermediate between a double and a single bond. Obviously, this cannot be represented by either of the two Lewis structures shown above.

The concept of resonance was introduced to deal with the type of difficulty experienced in the depiction of accurate structures of molecules like O_3 . **According to the concept of resonance, whenever a single Lewis structure cannot describe a molecule accurately, a number of structures with similar energy, positions of nuclei, bonding and non-bonding pairs of electrons are taken as the canonical structures of the hybrid which describes the molecule accurately.** Thus for O_3 , the two structures shown above constitute the canonical structures or resonance structures and their hybrid i.e., the III structure represents the structure of O_3 more accurately. This is also called **resonance hybrid**. Resonance is represented by a double headed arrow.

Some of the other examples of resonance structures are provided by the **carbonate ion and the carbon dioxide molecule**.

Problem 4.3

Explain the structure of CO_3^{2-} ion in terms of resonance.

Solution

The single Lewis structure based on the presence of two single bonds and one double bond between carbon and oxygen atoms is inadequate to represent the molecule accurately as it represents unequal bonds. According to the experimental findings, all carbon to oxygen bonds in CO_3^{2-} are equivalent. Therefore the carbonate ion is best described as a resonance hybrid of the canonical forms I, II, and III shown below.

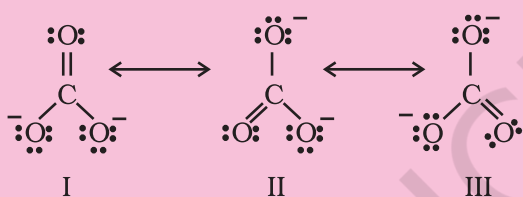

Fig. 4.4 Resonance in CO_3^{2-} , I, II and III represent the three canonical forms.

Problem 4.4

Explain the structure of CO_2 molecule.

Solution

The experimentally determined carbon to oxygen bond length in CO_2 is 115 pm. The lengths of a normal carbon to oxygen double bond ($\text{C}=\text{O}$) and carbon to oxygen triple bond ($\text{C}\equiv\text{O}$) are 121 pm and 110 pm respectively. The carbon-oxygen bond lengths in CO_2 (115 pm) lie between the values for $\text{C}=\text{O}$ and $\text{C}\equiv\text{O}$. Obviously, a single Lewis structure cannot depict this position and it becomes necessary to write more than one Lewis structures and to consider that the structure of CO_2 is best described as a hybrid of the canonical or resonance forms I, II and III.

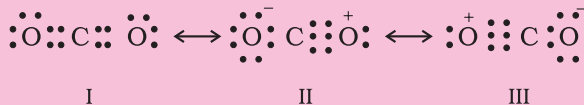

Fig. 4.5 Resonance in CO_2 molecule, I, II and III represent the three canonical forms.

In general, it may be stated that

- Resonance stabilizes the molecule as the energy of the resonance hybrid is less than the energy of any single canonical structure; and,
 - Resonance averages the bond characteristics as a whole.
- Thus the energy of the O_3 resonance hybrid is lower than either of the two canonical forms I and II (Fig. 4.3).

Many **misconceptions** are associated with resonance and the same need to be dispelled. You should remember that :

- The canonical forms have no real existence.
- The molecule does not exist for a certain fraction of time in one canonical form and for other fractions of time in other canonical forms.
- There is no such equilibrium between the canonical forms as we have between tautomeric forms (*keto* and *enol*) in tautomerism.
- The molecule as such has a single structure which is the resonance hybrid of the canonical forms and which cannot as such be depicted by a single Lewis structure.

4.3.6 Polarity of Bonds

The existence of a hundred percent ionic or covalent bond represents an ideal situation. In reality no bond or a compound is either completely covalent or ionic. Even in case of covalent bond between two hydrogen atoms, there is some ionic character.

When covalent bond is formed between two similar atoms, for example in H_2 , O_2 , Cl_2 , N_2 or F_2 , the shared pair of electrons is equally attracted by the two atoms. As a result

electron pair is situated exactly between the two identical nuclei. The bond so formed is called nonpolar covalent bond. Contrary to this in case of a heteronuclear molecule like HF, the shared electron pair between the two atoms gets displaced more towards fluorine since the electronegativity of fluorine (Unit 3) is far greater than that of hydrogen. The resultant covalent bond is a polar covalent bond.

As a result of polarisation, the molecule possesses the **dipole moment** (depicted below) which can be defined as the product of the magnitude of the charge and the distance between the centres of positive and negative charge. It is usually designated by a Greek letter ' μ '. Mathematically, it is expressed as follows :

$$\text{Dipole moment } (\mu) = \text{charge } (Q) \times \text{distance of separation } (r)$$

Dipole moment is usually expressed in Debye units (D). The conversion factor is

$$1 \text{ D} = 3.33564 \times 10^{-30} \text{ C m}$$

where C is coulomb and m is meter.

Further dipole moment is a vector quantity and by convention it is depicted by a small arrow with tail on the negative centre and head pointing towards the positive centre. But in chemistry presence of dipole moment is represented by the crossed arrow ($\rightarrow+$) put on Lewis structure of the molecule. The cross is on positive end and arrow head is on negative end. For example the dipole moment of HF may be represented as :

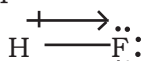

This arrow symbolises the direction of the shift of electron density in the molecule. Note that the direction of crossed arrow is opposite to the conventional direction of dipole moment vector.



Peter Debye, the Dutch chemist received Nobel prize in 1936 for his work on X-ray diffraction and dipole moments. The magnitude of the dipole moment is given in Debye units in order to honour him.

In case of polyatomic molecules the dipole moment not only depend upon the individual dipole moments of bonds known as bond dipoles but also on the spatial arrangement of various bonds in the molecule. In such case, the dipole moment of a molecule is the vector sum of the dipole moments of various bonds. For example in H_2O molecule, which has a bent structure, the two O–H bonds are oriented at an angle of 104.5° . Net dipole moment of $6.17 \times 10^{-30} \text{ C m}$ ($1\text{D} = 3.33564 \times 10^{-30} \text{ C m}$) is the resultant of the dipole moments of two O–H bonds.

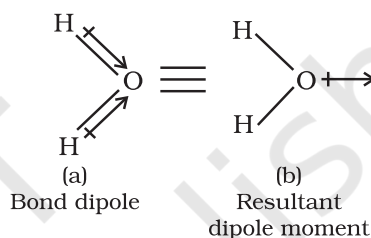

$$\text{Net Dipole moment, } \mu = 1.85 \text{ D}$$

$$= 1.85 \times 3.33564 \times 10^{-30} \text{ C m} = 6.17 \times 10^{-30} \text{ C m}$$

The dipole moment in case of BeF_2 is zero. This is because the two equal bond dipoles point in opposite directions and cancel the effect of each other.

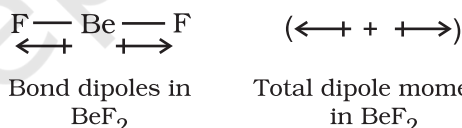

In tetra-atomic molecule, for example in BF_3 , the dipole moment is zero although the B–F bonds are oriented at an angle of 120° to one another, the three bond moments give a net sum of zero as the resultant of any two is equal and opposite to the third.

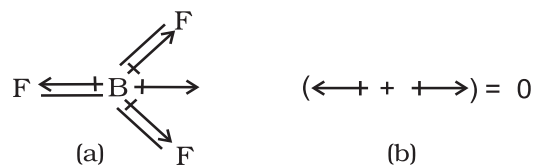

BF_3 molecule; representation of (a) bond dipoles and (b) total dipole moment

Let us study an interesting case of NH_3 and NF_3 molecule. Both the molecules have pyramidal shape with a lone pair of electrons on nitrogen atom. Although fluorine is more electronegative than nitrogen, the resultant

dipole moment of NH_3 (4.90×10^{-30} C m) is greater than that of NF_3 (0.8×10^{-30} C m). This is because, in case of NH_3 the orbital dipole due to lone pair is in the same direction as the resultant dipole moment of the N – H bonds, whereas in NF_3 the orbital dipole is in the direction opposite to the resultant dipole moment of the three N–F bonds. The orbital dipole because of lone pair decreases the effect of the resultant N – F bond moments, which results in the low dipole moment of NF_3 as represented below :

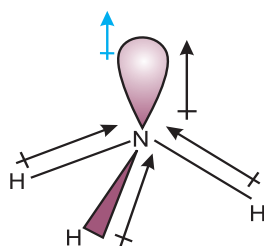

Resultant dipole moment in $\text{NH}_3 = 4.90 \times 10^{-30}$ C m

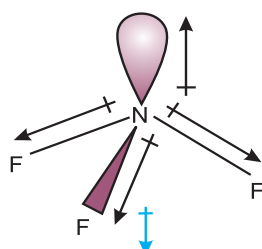

Resultant dipole moment in $\text{NF}_3 = 0.80 \times 10^{-30}$ C m

Dipole moments of some molecules are shown in Table 4.5.

Just as all the covalent bonds have some partial ionic character, the ionic bonds also have partial covalent character. The partial covalent character of ionic bonds was discussed by Fajans in terms of the following rules:

- The smaller the size of the cation and the larger the size of the anion, the greater the covalent character of an ionic bond.
- The greater the charge on the cation, the greater the covalent character of the ionic bond.
- For cations of the same size and charge, the one, with electronic configuration $(n-1)d^n ns^0$, typical of transition metals, is more polarising than the one with a noble gas configuration, $ns^2 np^6$, typical of alkali and alkaline earth metal cations.

The cation polarises the anion, pulling the electronic charge toward itself and thereby increasing the electronic charge between the two. This is precisely what happens in a covalent bond, i.e., buildup of electron charge density between the nuclei. The polarising power of the cation, the polarisability of the anion and the extent of distortion (polarisation) of anion are the factors, which determine the per cent covalent character of the ionic bond.

4.4 THE VALENCE SHELL ELECTRON PAIR REPULSION (VSEPR) THEORY

As already explained, Lewis concept is unable to explain the shapes of molecules. This theory provides a simple procedure to predict the shapes of covalent molecules. Sidgwick

Table 4.5 Dipole Moments of Selected Molecules

Type of Molecule	Example	Dipole Moment, $\mu(\text{D})$	Geometry
Molecule (AB)	HF	1.78	linear
	HCl	1.07	linear
	HBr	0.79	linear
	HI	0.38	linear
	H_2	0	linear
Molecule (AB₂)	H_2O	1.85	bent
	H_2S	0.95	bent
	CO_2	0	linear
Molecule (AB₃)	NH_3	1.47	trigonal-pyramidal
	NF_3	0.23	trigonal-pyramidal
	BF_3	0	trigonal-planar
Molecule (AB₄)	CH_4	0	tetrahedral
	CHCl_3	1.04	tetrahedral
	CCl_4	0	tetrahedral

and Powell in 1940, proposed a simple theory based on the repulsive interactions of the electron pairs in the valence shell of the atoms. It was further developed and redefined by Nyholm and Gillespie (1957).

The main postulates of VSEPR theory are as follows:

- The shape of a molecule depends upon the number of valence shell electron pairs (bonded or nonbonded) around the central atom.
- Pairs of electrons in the valence shell repel one another since their electron clouds are negatively charged.
- These pairs of electrons tend to occupy such positions in space that minimise repulsion and thus maximise distance between them.
- The valence shell is taken as a sphere with the electron pairs localising on the spherical surface at maximum distance from one another.
- A multiple bond is treated as if it is a single electron pair and the two or three electron pairs of a multiple bond are treated as a single super pair.
- Where two or more resonance structures can represent a molecule, the VSEPR model is applicable to any such structure.

The repulsive interaction of electron pairs decrease in the order:

Lone pair (lp) – Lone pair (lp) > Lone pair (lp) – Bond pair (bp) > Bond pair (bp) – Bond pair (bp)

Nyholm and Gillespie (1957) refined the VSEPR model by explaining the important difference between the lone pairs and bonding pairs of electrons. While the lone pairs are localised on the central atom, each bonded pair is shared between two atoms. As a result, the lone pair electrons in a molecule occupy more space as compared to the bonding pairs of electrons. This results in greater repulsion between lone pairs of electrons as compared to the lone pair - bond pair and bond pair - bond pair repulsions. These repulsion effects

result in deviations from idealised shapes and alterations in bond angles in molecules.

For the prediction of geometrical shapes of molecules with the help of VSEPR theory, it is convenient to divide molecules into two categories as **(i) molecules in which the central atom has no lone pair and (ii) molecules in which the central atom has one or more lone pairs.**

Table 4.6 (page 114) shows the arrangement of electron pairs about a central atom A (without any lone pairs) and geometries of some molecules/ions of the type AB. Table 4.7 (page 115) shows shapes of some simple molecules and ions in which the central atom has one or more lone pairs. Table 4.8 (page 116) explains the reasons for the distortions in the geometry of the molecule.

As depicted in Table 4.6, in the compounds of AB₂, AB₃, AB₄, AB₅ and AB₆, the arrangement of electron pairs and the B atoms around the central atom A are : **linear, trigonal planar, tetrahedral, trigonal-bipyramidal and octahedral**, respectively. Such arrangement can be seen in the molecules like BF₃ (AB₃), CH₄ (AB₄) and PCl₅ (AB₅) as depicted below by their ball and stick models.

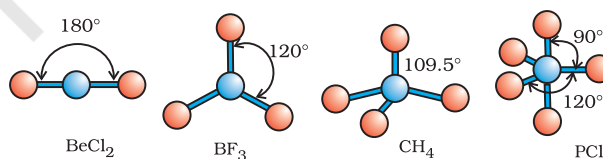

Fig. 4.6 The shapes of molecules in which central atom has no lone pair

The VSEPR Theory is able to predict geometry of a large number of molecules, especially the compounds of *p*-block elements accurately. It is also quite successful in determining the geometry quite-accurately even when the energy difference between possible structures is very small. The theoretical basis of the VSEPR theory regarding the effects of electron pair repulsions on molecular shapes is not clear and continues to be a subject of doubt and discussion.

Table 4.6 Geometry of Molecules in which the Central Atom has No Lone Pair of Electrons

Number of electron pairs	Arrangement of electron pairs	Molecular geometry	Examples
2	 <p>180° :—A—: Linear</p>	B—A—B Linear	BeCl ₂ , HgCl ₂
3	 <p>120° A Trigonal planar</p>	 <p>B A B B Trigonal planar</p>	BF ₃
4	 <p>109.5° A Tetrahedral</p>	 <p>B A B B B Tetrahedral</p>	CH ₄ , NH ₄ ⁺
5	 <p>90° 120° A Trigonal bipyramidal</p>	 <p>B A B B B Trigonal bipyramidal</p>	PCl ₅
6	 <p>90° 90° A Octahedral</p>	 <p>B A B B B B Octahedral</p>	SF ₆

Table 4.7 Shape (geometry) of Some Simple Molecules/Ions with Central Ions having One or More Lone Pairs of Electrons(E).

Molecule type	No. of bonding pairs	No. of lone pairs	Arrangement of electron pairs	Shape	Examples
AB_2E	2	1	 <p>Trigonal planer</p>	Bent	SO_2O_3
AB_3E	3	1	 <p>Tetrahedral</p>	Trigonal pyramidal	NH_3
AB_3E_2	2	2	 <p>Tetrahedral</p>	Bent	H_2O
AB_4E	4	1	 <p>Trigonal bi-pyramidal</p>	See saw	SF_4
AB_3E_2	3	2	 <p>Trigonal bi-pyramidal</p>	T-shape	ClF_3
AB_5E	5	1	 <p>Octahedral</p>	Square pyramid	BrF_5
AB_4E_2	4	2	 <p>Octahedral</p>	Square planer	XeF_4

Table 4.8 Shapes of Molecules containing Bond Pair and Lone Pair

Molecule type	No. of bonding pairs	No. of lone pairs	Arrangement of electrons	Shape	Reason for the shape acquired
AB_2E	4	1		Bent	Theoretically the shape should have been triangular planar but actually it is found to be bent or v-shaped. The reason being the lone pair-bond pair repulsion is much more as compared to the bond pair-bond pair repulsion. So the angle is reduced to 119.5° from 120° .
AB_3E	3	1		Trigonal pyramidal	Had there been a bp in place of lp the shape would have been tetrahedral but one lone pair is present and due to the repulsion between lp-bp (which is more than bp-bp repulsion) the angle between bond pairs is reduced to 107° from 109.5° .
AB_2E_2	2	2		Bent	The shape should have been tetrahedral if there were all bp but two lp are present so the shape is distorted tetrahedral or angular. The reason is lp-lp repulsion is more than lp-bp repulsion which is more than bp-bp repulsion. Thus, the angle is reduced to 104.5° from 109.5° .
AB_4E	4	1		See-saw	In (a) the lp is present at axial position so there are three lp-bp repulsions at 90° . In (b) the lp is in an equatorial position, and there are two lp-bp repulsions. Hence, arrangement (b) is more stable. The shape shown in (b) is described as a distorted tetrahedron, a folded square or a see-saw.

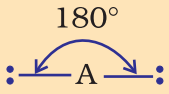
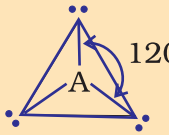
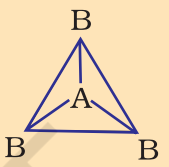
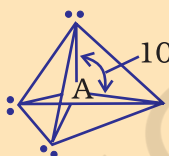
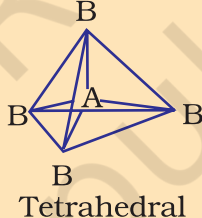
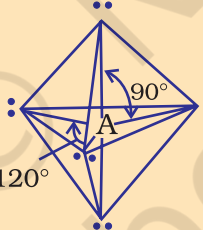
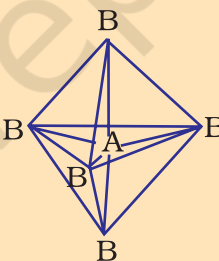
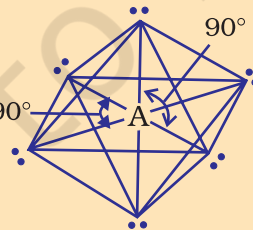
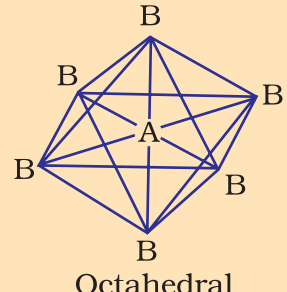
Molecule type	No. of bonding pairs	No. of lone pairs	Arrangement of electrons	Shape	Reason for the shape acquired
AB_3E_2	3	2		T-shape	In (a) the lp are at equatorial position so there are less lp-bp repulsions as compared to others in which the lp are at axial positions. So structure (a) is most stable. (T-shaped).

4.5 VALENCE BOND THEORY

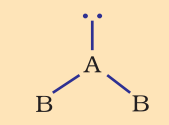
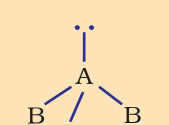
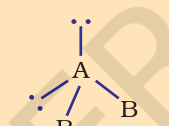
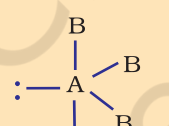
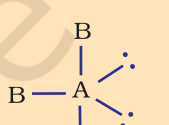
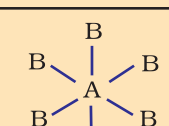
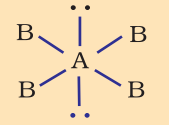
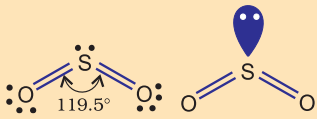
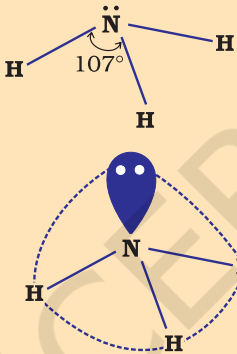
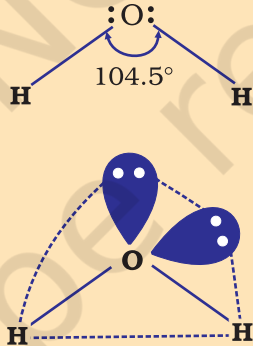
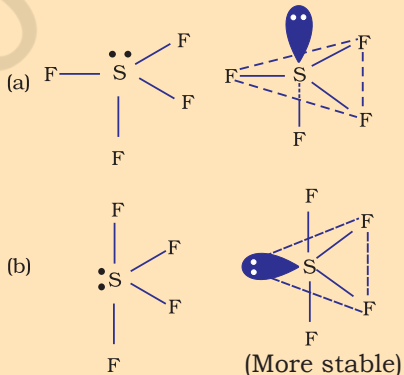
As we know that Lewis approach helps in writing the structure of molecules but it fails to explain the formation of chemical bond. It also does not give any reason for the difference in bond dissociation enthalpies and bond lengths in molecules like H_2 ($435.8 \text{ kJ mol}^{-1}$, 74 pm) and F_2 (155 kJ mol^{-1} , 144 pm), although in both the cases a single covalent bond is formed by the sharing of an electron pair between the respective atoms. It also gives no idea about the shapes of polyatomic molecules.

Similarly the VSEPR theory gives the geometry of simple molecules but theoretically, it does not explain them and also it has limited applications. To overcome these limitations the two important theories based on quantum mechanical principles are introduced. These are valence bond (VB) theory and molecular orbital (MO) theory.

Valence bond theory was introduced by Heitler and London (1927) and developed further by Pauling and others. A discussion

of the valence bond theory is based on the knowledge of atomic orbitals, electronic configurations of elements (Units 2), the overlap criteria of atomic orbitals, the hybridization of atomic orbitals and the principles of variation and superposition. A rigorous treatment of the VB theory in terms of these aspects is beyond the scope of this book. Therefore, for the sake of convenience, valence bond theory has been discussed in terms of qualitative and non-mathematical treatment only. To start with, let us consider the formation of hydrogen molecule which is the simplest of all molecules.

Consider two hydrogen atoms A and B approaching each other having nuclei N_A and N_B and electrons present in them are represented by e_A and e_B . When the two atoms are at large distance from each other, there is no interaction between them. As these two atoms approach each other, new attractive and repulsive forces begin to operate.

Attractive forces arise between:

- nucleus of one atom and its own electron that is $N_A - e_A$ and $N_B - e_B$.

- (ii) nucleus of one atom and electron of other atom i.e., $N_A - e_B$, $N_B - e_A$.

Similarly repulsive forces arise between

- (i) electrons of two atoms like $e_A - e_B$,
 (ii) nuclei of two atoms $N_A - N_B$.

Attractive forces tend to bring the two atoms close to each other whereas repulsive forces tend to push them apart (Fig. 4.7).

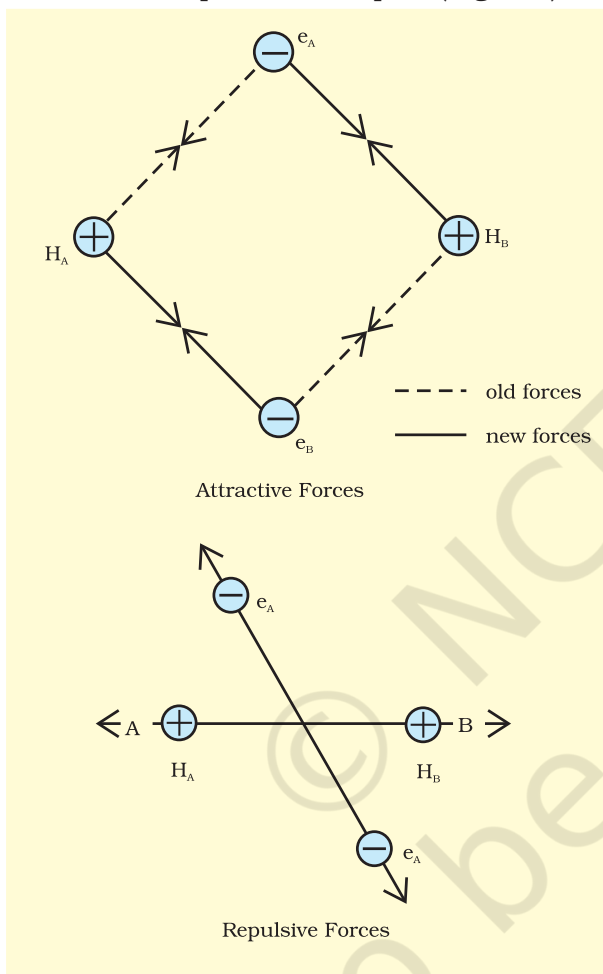

Fig. 4.7 Forces of attraction and repulsion during the formation of H_2 molecule

Experimentally it has been found that the magnitude of new attractive force is more than the new repulsive forces. As a result, two atoms approach each other and potential energy decreases. Ultimately a stage is reached where the net force of attraction balances the force of repulsion and system acquires minimum energy. At this stage two hydrogen atoms are said to be bonded

together to form a stable molecule having the bond length of 74 pm.

Since the energy gets released when the bond is formed between two hydrogen atoms, the hydrogen molecule is more stable than that of isolated hydrogen atoms. The energy so released is called as **bond enthalpy**, which is corresponding to minimum in the curve depicted in Fig. 4.8. Conversely, 435.8 kJ of energy is required to dissociate one mole of H_2 molecule.

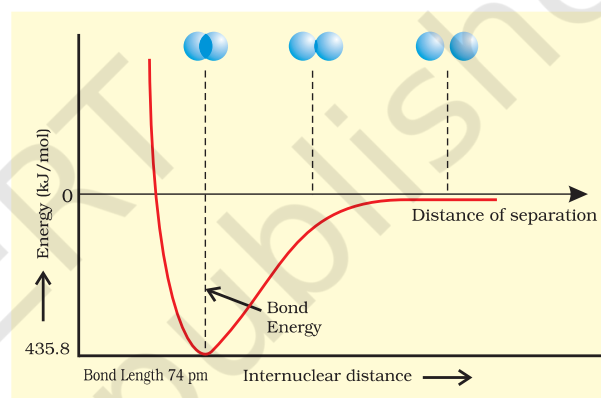
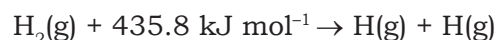

Fig. 4.8 The potential energy curve for the formation of H_2 molecule as a function of internuclear distance of the H atoms. The minimum in the curve corresponds to the most stable state of H_2 .

4.5.1 Orbital Overlap Concept

In the formation of hydrogen molecule, there is a minimum energy state when two hydrogen atoms are so near that their atomic orbitals undergo partial interpenetration. This partial merging of atomic orbitals is called overlapping of atomic orbitals which results in the pairing of electrons. The extent of overlap decides the strength of a covalent bond. In general, greater the overlap the stronger is the bond formed between two atoms. Therefore, according to orbital overlap concept, the formation of a covalent bond between two atoms results by pairing of electrons present in the valence shell having opposite spins.

4.5.2 Directional Properties of Bonds

As we have already seen, the covalent bond is formed by overlapping of atomic orbitals. The molecule of hydrogen is formed due to the overlap of 1s-orbitals of two H atoms.

In case of polyatomic molecules like CH_4 , NH_3 and H_2O , the geometry of the molecules is also important in addition to the bond formation. For example why is it so that CH_4 molecule has tetrahedral shape and HCH bond angles are 109.5° ? Why is the shape of NH_3 molecule pyramidal?

The valence bond theory explains the shape, the formation and directional properties of bonds in polyatomic molecules like CH_4 , NH_3 and H_2O , etc. in terms of overlap and hybridisation of atomic orbitals.

4.5.3 Overlapping of Atomic Orbitals

When orbitals of two atoms come close to form bond, their overlap may be positive, negative or zero depending upon the sign (phase) and direction of orientation of amplitude of orbital wave function in space (Fig. 4.9). Positive and negative sign on boundary surface diagrams in the Fig. 4.9 show the sign (phase) of orbital wave function and are not related to charge. Orbitals forming bond should have same sign (phase) and orientation in space. This is called positive overlap. Various overlaps of s and p orbitals are depicted in Fig. 4.9.

The criterion of overlap, as the main factor for the formation of covalent bonds applies uniformly to the homonuclear/heteronuclear diatomic molecules and polyatomic molecules. We know that the shapes of CH_4 , NH_3 , and H_2O molecules are tetrahedral, pyramidal and bent respectively. It would be therefore interesting to use VB theory to find out if these geometrical shapes can be explained in terms of the orbital overlaps.

Let us first consider the CH_4 (methane) molecule. The electronic configuration of carbon in its ground state is $[\text{He}]2s^2 2p^2$ which in the excited state becomes $[\text{He}] 2s^1 2p_x^1 2p_y^1 2p_z^1$. The energy required for this excitation is compensated by the release of energy due to overlap between the orbitals of carbon and the

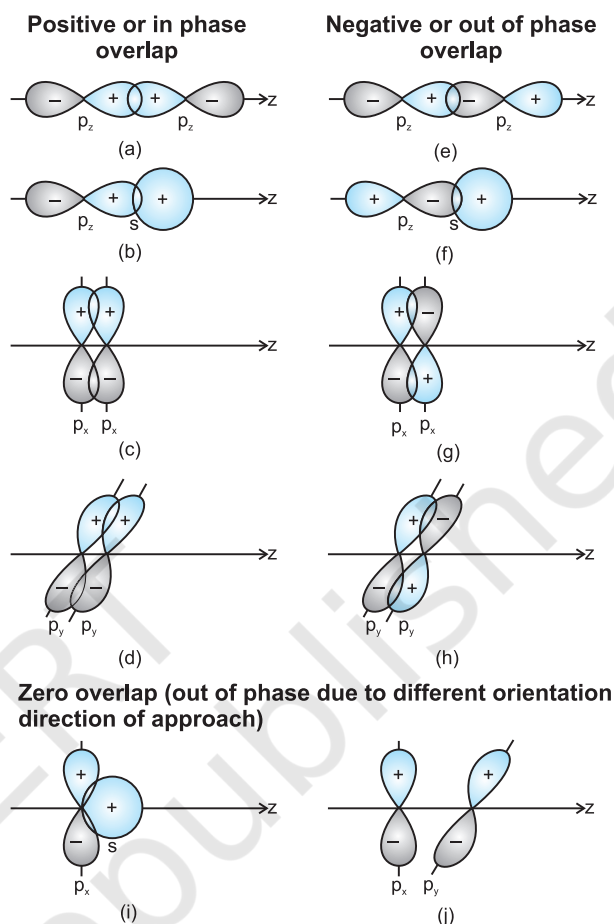

Fig. 4.9 Positive, negative and zero overlaps of s and p atomic orbitals

hydrogen. The four atomic orbitals of carbon, each with an unpaired electron can overlap with the 1s orbitals of the four H atoms which are also singly occupied. This will result in the formation of four C-H bonds. It will, however, be observed that while the three p orbitals of carbon are at 90° to one another, the HCH angle for these will also be 90° . That is three C-H bonds will be oriented at 90° to one another. The 2s orbital of carbon and the 1s orbital of H are spherically symmetrical and they can overlap in any direction. Therefore the direction of the fourth C-H bond cannot be ascertained. This description does not fit in with the tetrahedral HCH angles of 109.5° . Clearly, it follows that simple atomic orbital overlap does not account for the directional characteristics of bonds in CH_4 . Using similar procedure and arguments, it can be seen that in the case of NH_3 and H_2O molecules, the HNH

and HOH angles should be 90° . This is in disagreement with the actual bond angles of 107° and 104.5° in the NH_3 and H_2O molecules respectively.

4.5.4 Types of Overlapping and Nature of Covalent Bonds

The covalent bond may be classified into two types depending upon the types of overlapping:

(i) Sigma(σ) bond, and (ii) pi(π) bond

(i) **Sigma(σ) bond** : This type of covalent bond is formed by the end to end (head-on) overlap of bonding orbitals along the internuclear axis. This is called as head on overlap or axial overlap. This can be formed by any one of the following types of combinations of atomic orbitals.

- **s-s overlapping** : In this case, there is overlap of two half filled s-orbitals along the internuclear axis as shown below :



- **s-p overlapping**: This type of overlap occurs between half filled s-orbitals of one atom and half filled p-orbitals of another atom.



- **p-p overlapping** : This type of overlap takes place between half filled p-orbitals of the two approaching atoms.

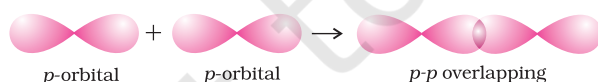

(ii) **pi(π) bond** : In the formation of π bond the atomic orbitals overlap in such a way that their axes remain parallel to each other and perpendicular to the internuclear axis. The orbitals formed due to sidewise overlapping consists of two saucer type charged clouds

above and below the plane of the participating atoms.

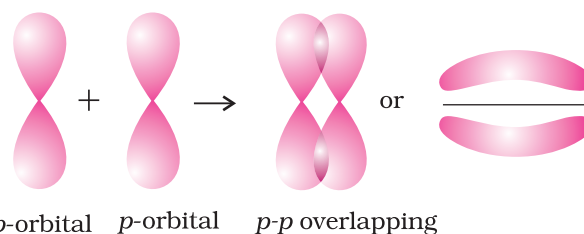

4.5.5 Strength of Sigma and pi Bonds

Basically the strength of a bond depends upon the extent of overlapping. In case of sigma bond, the overlapping of orbitals takes place to a larger extent. Hence, it is stronger as compared to the pi bond where the extent of overlapping occurs to a smaller extent. Further, it is important to note that in the formation of multiple bonds between two atoms of a molecule, pi bond(s) is formed in addition to a sigma bond.

4.6 HYBRIDISATION

In order to explain the characteristic geometrical shapes of polyatomic molecules like CH_4 , NH_3 and H_2O etc., Pauling introduced the concept of hybridisation. According to him the atomic orbitals combine to form new set of equivalent orbitals known as **hybrid orbitals**. Unlike pure orbitals, the hybrid orbitals are used in bond formation. The phenomenon is known as **hybridisation** which can be defined as the process of intermixing of the orbitals of slightly different energies so as to redistribute their energies, resulting in the formation of new set of orbitals of equivalent energies and shape. For example when one 2s and three 2p-orbitals of carbon hybridise, there is the formation of four new sp^3 hybrid orbitals.

Salient features of hybridisation: The main features of hybridisation are as under :

1. The number of hybrid orbitals is equal to the number of the atomic orbitals that get hybridised.
2. The hybridised orbitals are always equivalent in energy and shape.

- The hybrid orbitals are more effective in forming stable bonds than the pure atomic orbitals.
- These hybrid orbitals are directed in space in some preferred direction to have minimum repulsion between electron pairs and thus a stable arrangement. Therefore, the type of hybridisation indicates the geometry of the molecules.

Important conditions for hybridisation

- The orbitals present in the valence shell of the atom are hybridised.
- The orbitals undergoing hybridisation should have almost equal energy.
- Promotion of electron is not essential condition prior to hybridisation.
- It is not necessary that only half filled orbitals participate in hybridisation. In some cases, even filled orbitals of valence shell take part in hybridisation.

4.6.1 Types of Hybridisation

There are various types of hybridisation involving s , p and d orbitals. The different types of hybridisation are as under:

(I) sp hybridisation: This type of hybridisation involves the mixing of one s and one p orbital resulting in the formation of two equivalent sp hybrid orbitals. The suitable orbitals for sp hybridisation are s and p_z , if the hybrid orbitals are to lie along the z -axis. Each sp hybrid orbital has 50% s -character and 50% p -character. Such a molecule in which the central atom is sp -hybridised and linked directly to two other central atoms possesses linear geometry. This type of hybridisation is also known as diagonal hybridisation.

The two sp hybrids point in the opposite direction along the z -axis with projecting positive lobes and very small negative lobes, which provides more effective overlapping resulting in the formation of stronger bonds.

Example of molecule having sp hybridisation

$BeCl_2$: The ground state electronic configuration of Be is $1s^2 2s^2$. In the excited state one of the $2s$ -electrons is promoted to

vacant $2p$ orbital to account for its bivalency. One $2s$ and one $2p$ -orbital gets hybridised to form two sp hybridised orbitals. These two sp hybrid orbitals are oriented in opposite direction forming an angle of 180° . Each of the sp hybridised orbital overlaps with the $2p$ -orbital of chlorine axially and form two Be-Cl sigma bonds. This is shown in Fig. 4.10.

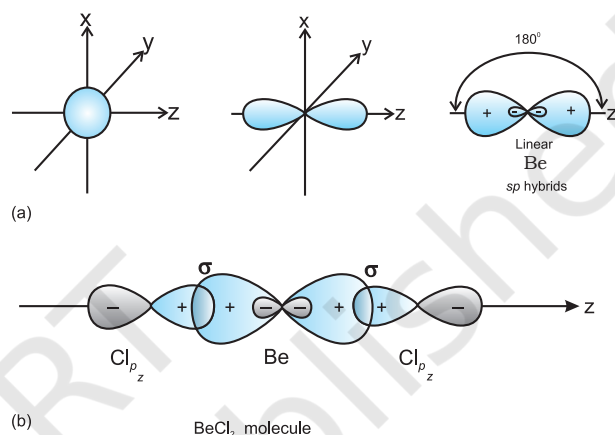

Fig.4.10 (a) Formation of sp hybrids from s and p orbitals; (b) Formation of the linear $BeCl_2$ molecule

(II) sp^2 hybridisation : In this hybridisation there is involvement of one s and two p -orbitals in order to form three equivalent sp^2 hybridised orbitals. For example, in BCl_3 molecule, the ground state electronic configuration of central boron atom is $1s^2 2s^2 2p^1$. In the excited state, one of the $2s$ electrons is promoted to vacant $2p$ orbital as

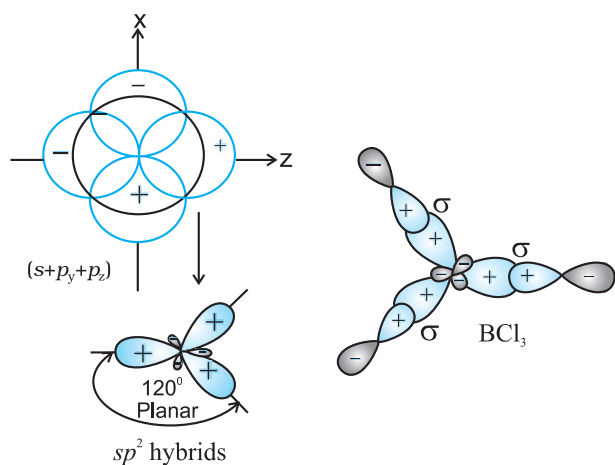

Fig.4.11 Formation of sp^2 hybrids and the BCl_3 molecule

a result boron has three unpaired electrons. These three orbitals (one $2s$ and two $2p$) hybridise to form three sp^2 hybrid orbitals. The three hybrid orbitals so formed are oriented in a trigonal planar arrangement and overlap with $2p$ orbitals of chlorine to form three B-Cl bonds. Therefore, in BCl_3 (Fig. 4.11), the geometry is trigonal planar with ClBCl bond angle of 120° .

(III) sp^3 hybridisation: This type of hybridisation can be explained by taking the example of CH_4 molecule in which there is mixing of one s -orbital and three p -orbitals of the valence shell to form four sp^3 hybrid orbital of equivalent energies and shape. There is 25% s -character and 75% p -character in each sp^3 hybrid orbital. The four sp^3 hybrid orbitals so formed are directed towards the four corners of the tetrahedron. The angle between sp^3 hybrid orbital is 109.5° as shown in Fig. 4.12.

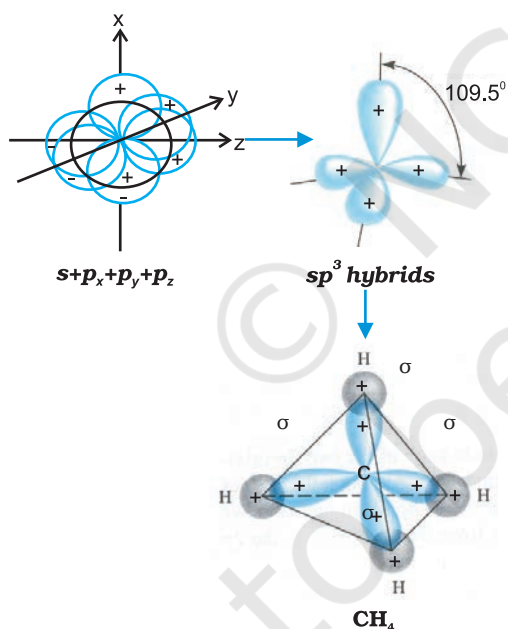

Fig.4.12 Formation of sp^3 hybrids by the combination of s, p_x, p_y and p_z atomic orbitals of carbon and the formation of CH_4 molecule

The structure of NH_3 and H_2O molecules can also be explained with the help of sp^3 hybridisation. In NH_3 , the valence shell (outer) electronic configuration of nitrogen in the

ground state is $2S^2 2p_x^1 2p_y^1 2p_z^1$ having three unpaired electrons in the sp^3 hybrid orbitals and a lone pair of electrons is present in the fourth one. These three hybrid orbitals overlap with $1s$ orbitals of hydrogen atoms to form three N-H sigma bonds. We know that the force of repulsion between a lone pair and a bond pair is more than the force of repulsion between two bond pairs of electrons. The molecule thus gets distorted and the bond angle is reduced to 107° from 109.5° . The geometry of such a molecule will be pyramidal as shown in Fig. 4.13.

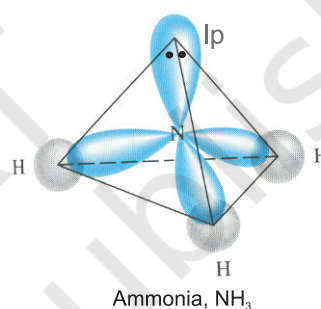

Fig.4.13 Formation of NH_3 molecule

In case of H_2O molecule, the four oxygen orbitals (one $2s$ and three $2p$) undergo sp^3 hybridisation forming four sp^3 hybrid orbitals out of which two contain one electron each and the other two contain a pair of electrons. These four sp^3 hybrid orbitals acquire a tetrahedral geometry, with two corners occupied by hydrogen atoms while the other two by the lone pairs. The bond angle in this case is reduced to 104.5° from 109.5° (Fig. 4.14) and the molecule thus acquires a V-shape or angular geometry.

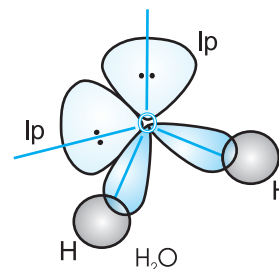

Fig.4.14 Formation of H_2O molecule

4.6.2 Other Examples of sp^3 , sp^2 and sp Hybridisation

sp^3 Hybridisation in C_2H_6 molecule: In ethane molecule both the carbon atoms assume sp^3 hybrid state. One of the four sp^3 hybrid orbitals of carbon atom overlaps axially with similar orbitals of other atom to form sp^3-sp^3 sigma bond while the other three hybrid orbitals of each carbon atom are used in forming sp^3-s sigma bonds with hydrogen atoms as discussed in section 4.6.1(iii). Therefore in ethane C–C bond length is 154 pm and each C–H bond length is 109 pm.

sp^2 Hybridisation in C_2H_4 : In the formation of ethene molecule, one of the sp^2 hybrid orbitals of carbon atom overlaps axially with sp^2 hybridised orbital of another carbon atom to form C–C sigma bond. While the other two sp^2 hybrid orbitals of each carbon atom are

used for making sp^2-s sigma bond with two hydrogen atoms. The unhybridised orbital ($2p_x$ or $2p_y$) of one carbon atom overlaps sidewise with the similar orbital of the other carbon atom to form weak π bond, which consists of two equal electron clouds distributed above and below the plane of carbon and hydrogen atoms.

Thus, in ethene molecule, the carbon-carbon bond consists of one sp^2-sp^2 sigma bond and one pi (π) bond between p orbitals which are not used in the hybridisation and are perpendicular to the plane of molecule; the bond length 134 pm. The C–H bond is sp^2-s sigma with bond length 108 pm. The H–C–H bond angle is 117.6° while the H–C–C angle is 121° . The formation of sigma and pi bonds in ethene is shown in Fig. 4.15.

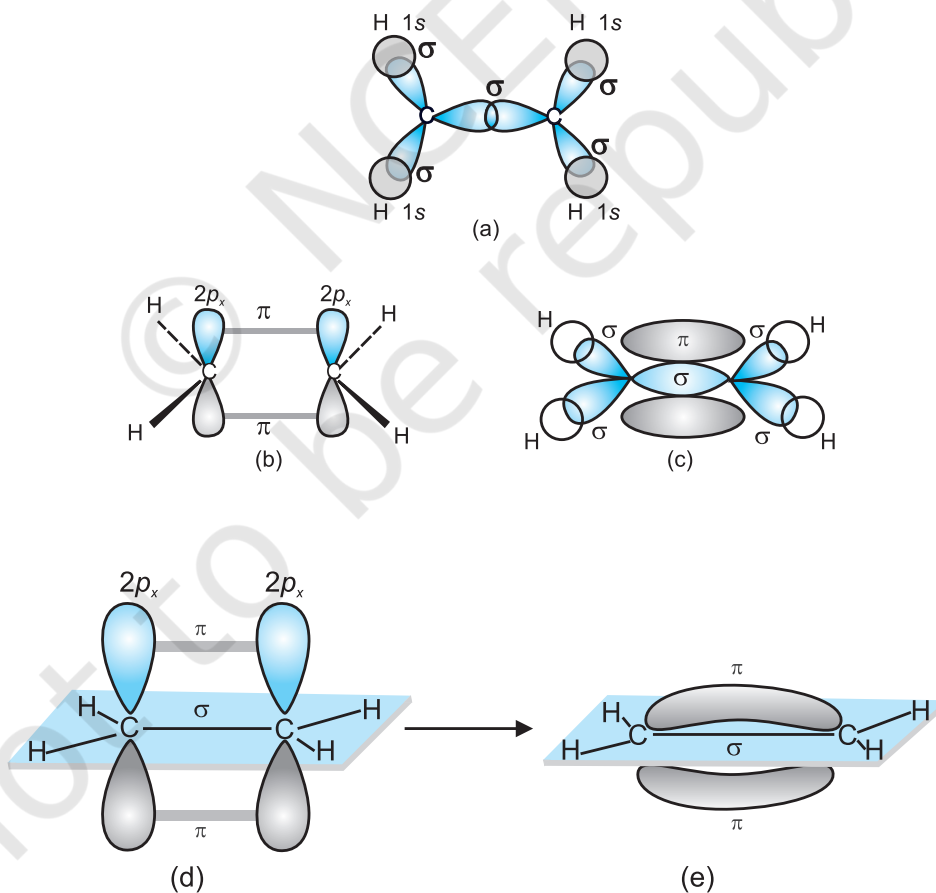
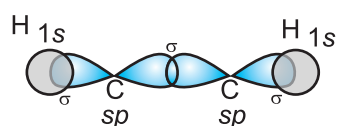

Fig. 4.15 Formation of sigma and pi bonds in ethene

***sp* Hybridisation in C_2H_2 :** In the formation of ethyne molecule, both the carbon atoms undergo *sp*-hybridisation having two unhybridised orbital *i.e.*, $2p_y$ and $2p_x$.

One *sp* hybrid orbital of one carbon atom overlaps axially with *sp* hybrid orbital of the other carbon atom to form C–C sigma bond, while the other hybridised orbital of each carbon atom overlaps axially with the half filled *s* orbital of hydrogen atoms forming σ bonds. Each of the two unhybridised *p* orbitals of both the carbon atoms overlaps sidewise to form two π bonds between the carbon atoms. So the triple bond between the two carbon atoms is made up of one sigma and two pi bonds as shown in Fig. 4.16.



(a)

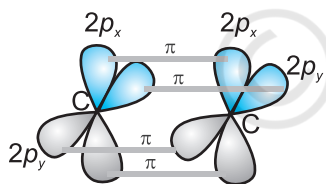

(b)

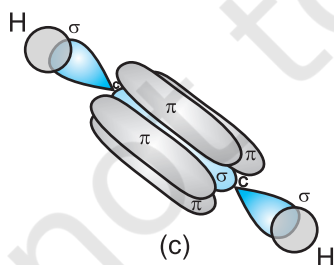

(c)

Fig. 4.16 Formation of sigma and pi bonds in ethyne

4.6.3 Hybridisation of Elements involving *d* Orbitals

The elements present in the third period contain *d* orbitals in addition to *s* and *p* orbitals. The energy of the 3*d* orbitals are comparable to the energy of the 3*s* and 3*p* orbitals. The energy of 3*d* orbitals are also comparable to those of 4*s* and 4*p* orbitals. As a consequence the hybridisation involving either 3*s*, 3*p* and 3*d* or 3*d*, 4*s* and 4*p* is possible. However, since the difference in energies of 3*p* and 4*s* orbitals is significant, no hybridisation involving 3*p*, 3*d* and 4*s* orbitals is possible.

The important hybridisation schemes involving *s*, *p* and *d* orbitals are summarised below:

Shape of molecules/ions	Hybridisation type	Atomic orbitals	Examples
Square planar	dsp^2	$d+s+p(2)$	$[Ni(CN)_4]^{2-}$, $[Pt(Cl)_4]^{2-}$
Trigonal bipyramidal	sp^3d	$s+p(3)+d$	PF_5 , PCl_5
Square pyramidal	sp^3d^2	$s+p(3)+d(2)$	BrF_5
Octahedral	sp^3d^2 d^2sp^3	$s+p(3)+d(2)$ $d(2)+s+p(3)$	SF_6 , $[CrF_6]^{3-}$ $[Co(NH_3)_6]^{3+}$

(i) Formation of PCl_5 (sp^3d hybridisation):

The ground state and the excited state outer electronic configurations of phosphorus ($Z=15$) are represented below.

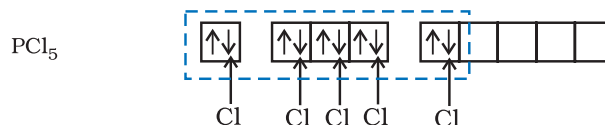
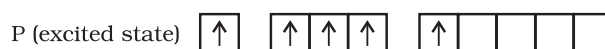
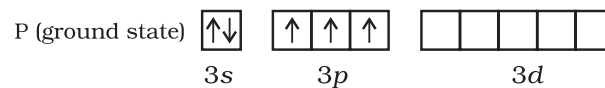

sp^3d hybrid orbitals filled by electron pairs donated by five Cl atoms.

Now the five orbitals (*i.e.*, one *s*, three *p* and one *d* orbitals) are available for hybridisation to yield a set of five sp^3d hybrid orbitals which are directed towards the five corners of a trigonal bipyramidal as depicted in the Fig. 4.17.

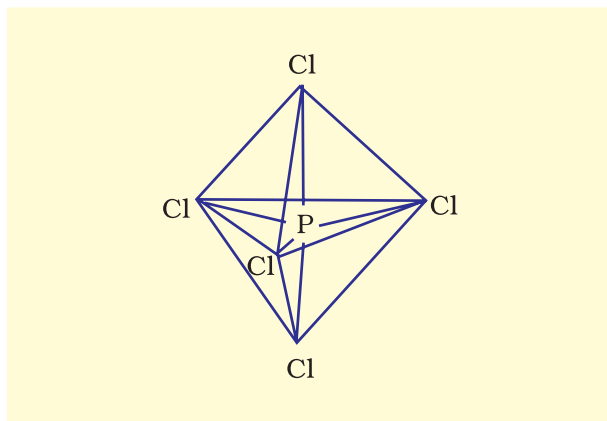

Fig. 4.17 Trigonal bipyramidal geometry of PCl_5 molecule

It should be noted that all the bond angles in trigonal bipyramidal geometry are not equivalent. In PCl_5 the five sp^3d orbitals of phosphorus overlap with the singly occupied *p* orbitals of chlorine atoms to form five P–Cl sigma bonds. Three P–Cl bond lie in one plane and make an angle of 120° with each other; these bonds are termed as equatorial bonds. The remaining two P–Cl bonds—one lying above and the other lying below the equatorial plane, make an angle of 90° with the plane. These bonds are called axial bonds. As the axial bond pairs suffer more repulsive interaction from the equatorial bond pairs, therefore axial bonds have been found to be slightly longer and hence slightly weaker than the equatorial bonds; which makes PCl_5 molecule more reactive.

(ii) Formation of SF_6 (sp^3d^2 hybridisation): In SF_6 the central sulphur atom has the ground state outer electronic configuration $3s^23p^4$. In the excited state the available six orbitals *i.e.*, one *s*, three *p* and two *d* are singly occupied by electrons. These orbitals hybridise to form six new sp^3d^2 hybrid orbitals, which are projected towards the six corners of a regular octahedron in SF_6 . These

six sp^3d^2 hybrid orbitals overlap with singly occupied orbitals of fluorine atoms to form six S–F sigma bonds. Thus SF_6 molecule has a regular octahedral geometry as shown in Fig. 4.18.

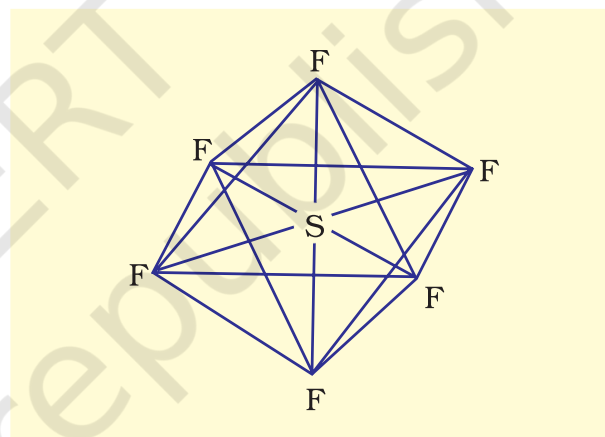
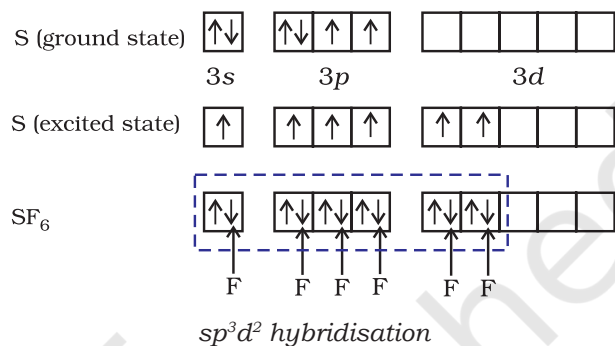

Fig. 4.18 Octahedral geometry of SF_6 molecule

4.7 MOLECULAR ORBITAL THEORY

Molecular orbital (MO) theory was developed by F. Hund and R.S. Mulliken in 1932. The salient features of this theory are :

- The electrons in a molecule are present in the various molecular orbitals as the electrons of atoms are present in the various atomic orbitals.
- The atomic orbitals of comparable energies and proper symmetry combine to form molecular orbitals.
- While an electron in an atomic orbital is influenced by one nucleus, in a molecular orbital it is influenced by two or more nuclei depending upon the number of atoms in the molecule. Thus,

an atomic orbital is monocentric while a molecular orbital is polycentric.

- (iv) The number of molecular orbital formed is equal to the number of combining atomic orbitals. When two atomic orbitals combine, two molecular orbitals are formed. One is known as **bonding molecular orbital** while the other is called **antibonding molecular orbital**.
- (v) The bonding molecular orbital has lower energy and hence greater stability than the corresponding antibonding molecular orbital.
- (vi) Just as the electron probability distribution around a nucleus in an atom is given by an atomic orbital, the electron probability distribution around a group of nuclei in a molecule is given by a molecular orbital.
- (vii) The molecular orbitals like atomic orbitals are filled in accordance with the *aufbau* principle obeying the Pauli's exclusion principle and the Hund's rule.

4.7.1 Formation of Molecular Orbitals Linear Combination of Atomic Orbitals (LCAO)

According to wave mechanics, the atomic orbitals can be expressed by wave functions (ψ 's) which represent the amplitude of the electron waves. These are obtained from the solution of Schrödinger wave equation. However, since it cannot be solved for any system containing more than one electron, molecular orbitals which are one electron wave functions for molecules are difficult to obtain directly from the solution of Schrödinger wave equation. To overcome this problem, an approximate method known as **linear combination of atomic orbitals (LCAO)** has been adopted.

Let us apply this method to the homonuclear diatomic hydrogen molecule. Consider the hydrogen molecule consisting of two atoms A and B. Each hydrogen atom in the ground state has one electron in 1s orbital. The atomic orbitals of these atoms may be represented by the wave functions

ψ_A and ψ_B . Mathematically, the formation of molecular orbitals may be described by the linear combination of atomic orbitals that can take place by addition and by subtraction of wave functions of individual atomic orbitals as shown below :

$$\psi_{MO} = \psi_A \pm \psi_B$$

Therefore, the two molecular orbitals σ and σ^* are formed as :

$$\sigma = \psi_A + \psi_B$$

$$\sigma^* = \psi_A - \psi_B$$

The molecular orbital σ formed by the addition of atomic orbitals is called the **bonding molecular orbital** while the molecular orbital σ^* formed by the subtraction of atomic orbital is called **antibonding molecular orbital** as depicted in Fig. 4.19.

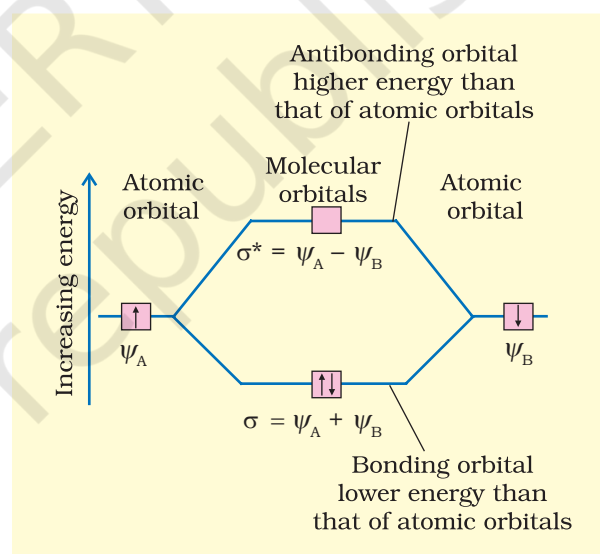

Fig.4.19 Formation of bonding (σ) and antibonding (σ^*) molecular orbitals by the linear combination of atomic orbitals ψ_A and ψ_B centered on two atoms A and B respectively.

Qualitatively, the formation of molecular orbitals can be understood in terms of the constructive or destructive interference of the electron waves of the combining atoms. In the formation of bonding molecular orbital, the two electron waves of the bonding atoms reinforce each other due to constructive interference while in the formation of

antibonding molecular orbital, the electron waves cancel each other due to destructive interference. As a result, the electron density in a bonding molecular orbital is located between the nuclei of the bonded atoms because of which the repulsion between the nuclei is very less while in case of an antibonding molecular orbital, most of the electron density is located away from the space between the nuclei. Infact, there is a nodal plane (on which the electron density is zero) between the nuclei and hence the repulsion between the nuclei is high. Electrons placed in a bonding molecular orbital tend to hold the nuclei together and stabilise a molecule. Therefore, a bonding molecular orbital always possesses lower energy than either of the atomic orbitals that have combined to form it. In contrast, the electrons placed in the antibonding molecular orbital destabilise the molecule. This is because the mutual repulsion of the electrons in this orbital is more than the attraction between the electrons and the nuclei, which causes a net increase in energy.

It may be noted that the energy of the antibonding orbital is raised above the energy of the parent atomic orbitals that have combined and the energy of the bonding orbital has been lowered than the parent orbitals. The total energy of two molecular orbitals, however, remains the same as that of two original atomic orbitals.

4.7.2 Conditions for the Combination of Atomic Orbitals

The linear combination of atomic orbitals to form molecular orbitals takes place only if the following conditions are satisfied:

1. The combining atomic orbitals must have the same or nearly the same energy.

This means that 1s orbital can combine with another 1s orbital but not with 2s orbital because the energy of 2s orbital is appreciably higher than that of 1s orbital. This is not true if the atoms are very different.

2. The combining atomic orbitals must have the same symmetry about the molecular axis.

By convention z-axis is taken

as the molecular axis. It is important to note that atomic orbitals having same or nearly the same energy will not combine if they do not have the same symmetry. For example, $2p_z$ orbital of one atom can combine with $2p_z$ orbital of the other atom but not with the $2p_x$ or $2p_y$ orbitals because of their different symmetries.

3. The combining atomic orbitals must overlap to the maximum extent. Greater the extent of overlap, the greater will be the electron-density between the nuclei of a molecular orbital.

4.7.3 Types of Molecular Orbitals

Molecular orbitals of diatomic molecules are designated as σ (sigma), π (pi), δ (delta), etc.

In this nomenclature, the **sigma (σ) molecular orbitals are symmetrical around the bond-axis while pi (π) molecular orbitals are not symmetrical.** For example, the linear combination of 1s orbitals centered on two nuclei produces two molecular orbitals which are symmetrical around the bond-axis. Such molecular orbitals are of the σ type and are designated as $\sigma 1s$ and $\sigma^* 1s$ [Fig. 4.20(a), page 124]. **If internuclear axis is taken to be in the z-direction, it can be seen that a linear combination of $2p_z$ - orbitals of two atoms also produces two sigma molecular orbitals designated as $\sigma 2p_z$ and $\sigma^* 2p_z$.** [Fig. 4.20(b)]

Molecular orbitals obtained from $2p_x$ and $2p_y$ orbitals are not symmetrical around the bond axis because of the presence of positive lobes above and negative lobes below the molecular plane. Such molecular orbitals, are labelled as π and π^* [Fig. 4.20(c)]. A π bonding MO has larger electron density above and below the inter-nuclear axis. The π^* antibonding MO has a node between the nuclei.

4.7.4 Energy Level Diagram for Molecular Orbitals

We have seen that 1s atomic orbitals on two atoms form two molecular orbitals designated as $\sigma 1s$ and $\sigma^* 1s$. In the same manner, the 2s and $2p$ atomic orbitals (eight atomic orbitals

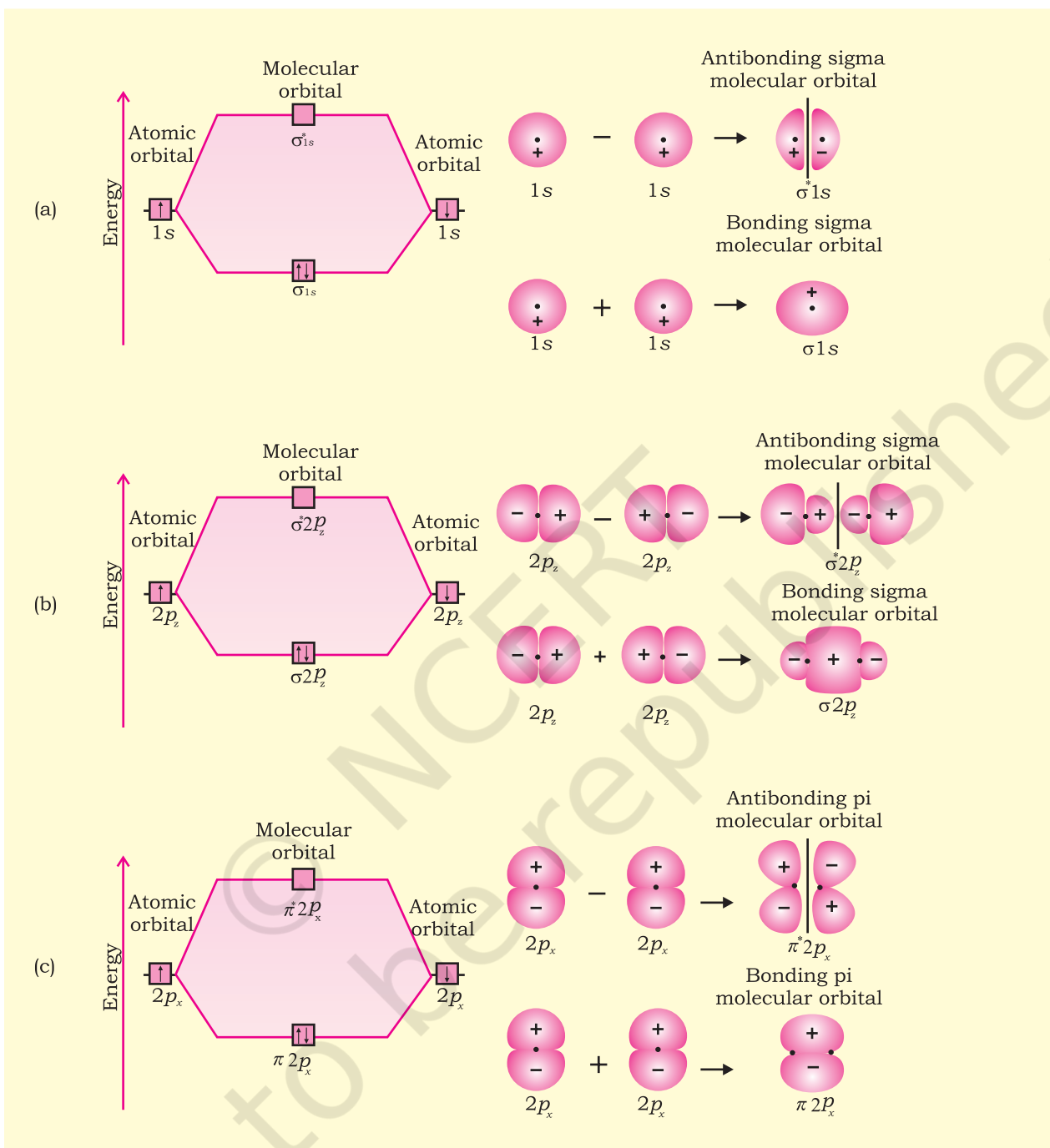

Fig. 4.20 Contours and energies of bonding and antibonding molecular orbitals formed through combinations of (a) 1s atomic orbitals; (b) $2p_z$ atomic orbitals and (c) $2p_x$ atomic orbitals.

on two atoms) give rise to the following eight molecular orbitals:

Antibonding	MOs	σ^*2s	σ^*2p_z	π^*2p_x	π^*2p_y
Bonding	MOs	$\sigma 2s$	$\sigma 2p_z$	$\pi 2p_x$	$\pi 2p_y$

The energy levels of these molecular orbitals have been determined experimentally from spectroscopic data for homonuclear diatomic molecules of second row elements of the periodic table. The increasing order of

energies of various molecular orbitals for O_2 and F_2 is given below:

$$\sigma 1s < \sigma^* 1s < \sigma 2s < \sigma^* 2s < \sigma 2p_z < (\pi 2p_x = \pi 2p_y) < (\pi^* 2p_x = \pi^* 2p_y) < \sigma^* 2p_z$$

However, this sequence of energy levels of molecular orbitals is not correct for the remaining molecules Li_2 , Be_2 , B_2 , C_2 , N_2 . For instance, it has been observed experimentally that for molecules such as B_2 , C_2 , N_2 , etc. the increasing order of energies of various molecular orbitals is

$$\sigma 1s < \sigma^* 1s < \sigma 2s < \sigma^* 2s < (\pi 2p_x = \pi 2p_y) < \sigma 2p_z < (\pi^* 2p_x = \pi^* 2p_y) < \sigma^* 2p_z$$

The important characteristic feature of this order is that the **energy of $\sigma 2p_z$ molecular orbital is higher than that of $\pi 2p_x$ and $\pi 2p_y$ molecular orbitals.**

4.7.5 Electronic Configuration and Molecular Behaviour

The distribution of electrons among various molecular orbitals is called the **electronic configuration of the molecule**. From the electronic configuration of the molecule, it is possible to get important information about the molecule as discussed below.

Stability of Molecules: If N_b is the number of electrons occupying bonding orbitals and N_a the number occupying the antibonding orbitals, then

- (i) the molecule is stable if N_b is greater than N_a , and
- (ii) the molecule is unstable if N_b is less than N_a .

In (i) more bonding orbitals are occupied and so the bonding influence is stronger and a stable molecule results. In (ii) the antibonding influence is stronger and therefore the molecule is unstable.

Bond order

Bond order (b.o.) is defined as one half the difference between the number of electrons present in the bonding and the antibonding orbitals i.e.,

$$\text{Bond order (b.o.)} = \frac{1}{2} (N_b - N_a)$$

The rules discussed above regarding the stability of the molecule can be restated in terms of bond order as follows: A positive bond order (i.e., $N_b > N_a$) means a stable molecule while a negative (i.e., $N_b < N_a$) or zero (i.e., $N_b = N_a$) bond order means an unstable molecule.

Nature of the bond

Integral bond order values of 1, 2 or 3 correspond to single, double or triple bonds respectively as studied in the classical concept.

Bond-length

The bond order between two atoms in a molecule may be taken as an approximate measure of the bond length. The bond length decreases as bond order increases.

Magnetic nature

If all the molecular orbitals in a molecule are doubly occupied, the substance is diamagnetic (repelled by magnetic field). However if one or more molecular orbitals are singly occupied it is paramagnetic (attracted by magnetic field), e.g., O_2 molecule.

4.8 BONDING IN SOME HOMONUCLEAR DIATOMIC MOLECULES

In this section we shall discuss bonding in some homonuclear diatomic molecules.

1. Hydrogen molecule (H_2): It is formed by the combination of two hydrogen atoms. Each hydrogen atom has one electron in 1s orbital. Therefore, in all there are two electrons in hydrogen molecule which are present in $\sigma 1s$ molecular orbital. So electronic configuration of hydrogen molecule is

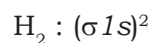

The bond order of H_2 molecule can be calculated as given below:

$$\text{Bond order} = \frac{N_b - N_a}{2} = \frac{2 - 0}{2} = 1$$

This means that the two hydrogen atoms are bonded together by a single covalent bond. The bond dissociation energy of hydrogen molecule has been found to be 438 kJ mol^{-1} and bond length equal to 74 pm. Since no

unpaired electron is present in hydrogen molecule, therefore, it is diamagnetic.

2. Helium molecule (He_2): The electronic configuration of helium atom is $1s^2$. Each helium atom contains 2 electrons, therefore, in He_2 molecule there would be 4 electrons. These electrons will be accommodated in $\sigma 1s$ and $\sigma^* 1s$ molecular orbitals leading to electronic configuration:

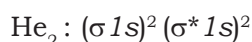

$$\text{Bond order of He}_2 \text{ is } \frac{1}{2}(2 - 2) = 0$$

He_2 molecule is therefore unstable and does not exist.

Similarly, it can be shown that Be_2 molecule $(\sigma 1s)^2 (\sigma^* 1s)^2 (\sigma 2s)^2 (\sigma^* 2s)^2$ also does not exist.

3. Lithium molecule (Li_2): The electronic configuration of lithium is $1s^2, 2s^1$. There are six electrons in Li_2 . The electronic configuration of Li_2 molecule, therefore, is

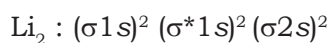

The above configuration is also written as $\text{KK}(\sigma 2s)^2$ where KK represents the closed K shell structure $(\sigma 1s)^2 (\sigma^* 1s)^2$.

From the electronic configuration of Li_2 molecule it is clear that there are four electrons present in bonding molecular orbitals and two electrons present in antibonding molecular orbitals. Its bond order, therefore, is $\frac{1}{2}(4 - 2) = 1$. It means that Li_2 molecule is stable and since it has no unpaired electrons it should be diamagnetic. Indeed diamagnetic Li_2 molecules are known to exist in the vapour phase.

4. Carbon molecule (C_2): The electronic configuration of carbon is $1s^2 2s^2 2p^2$. There are twelve electrons in C_2 . The electronic configuration of C_2 molecule, therefore, is



The bond order of C_2 is $\frac{1}{2}(8 - 4) = 2$ and C_2 should be diamagnetic. Diamagnetic C_2 molecules have indeed been detected in

vapour phase. It is important to note that double bond in C_2 consists of both pi bonds because of the presence of four electrons in two pi molecular orbitals. In most of the other molecules a double bond is made up of a sigma bond and a pi bond. In a similar fashion the bonding in N_2 molecule can be discussed.

5. Oxygen molecule (O_2): The electronic configuration of oxygen atom is $1s^2 2s^2 2p^4$. Each oxygen atom has 8 electrons, hence, in O_2 molecule there are 16 electrons. The electronic configuration of O_2 molecule, therefore, is

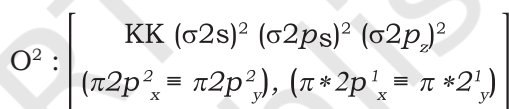
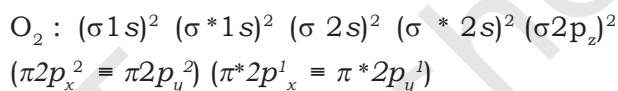

From the electronic configuration of O_2 molecule it is clear that ten electrons are present in bonding molecular orbitals and six electrons are present in antibonding molecular orbitals. Its bond order, therefore, is

$$\text{Bond order} = \frac{1}{2} [N_b - N_a] = \frac{1}{2} [10 - 6] = 2$$

So in oxygen molecule, atoms are held by a double bond. Moreover, it may be noted that it contains two unpaired electrons in $\pi^* 2p_x$ and $\pi^* 2p_y$ molecular orbitals, therefore, **O_2 molecule should be paramagnetic, a prediction that corresponds to experimental observation.** In this way, the theory successfully explains the paramagnetic nature of oxygen.

Similarly, the electronic configurations of other homonuclear diatomic molecules of the second row of the periodic table can be written. In Fig. 4.21 are given the molecular orbital occupancy and molecular properties for B_2 through Ne_2 . The sequence of MOs and their electron population are shown. The bond energy, bond length, bond order, magnetic properties and valence electron configuration appear below the orbital diagrams.

[]

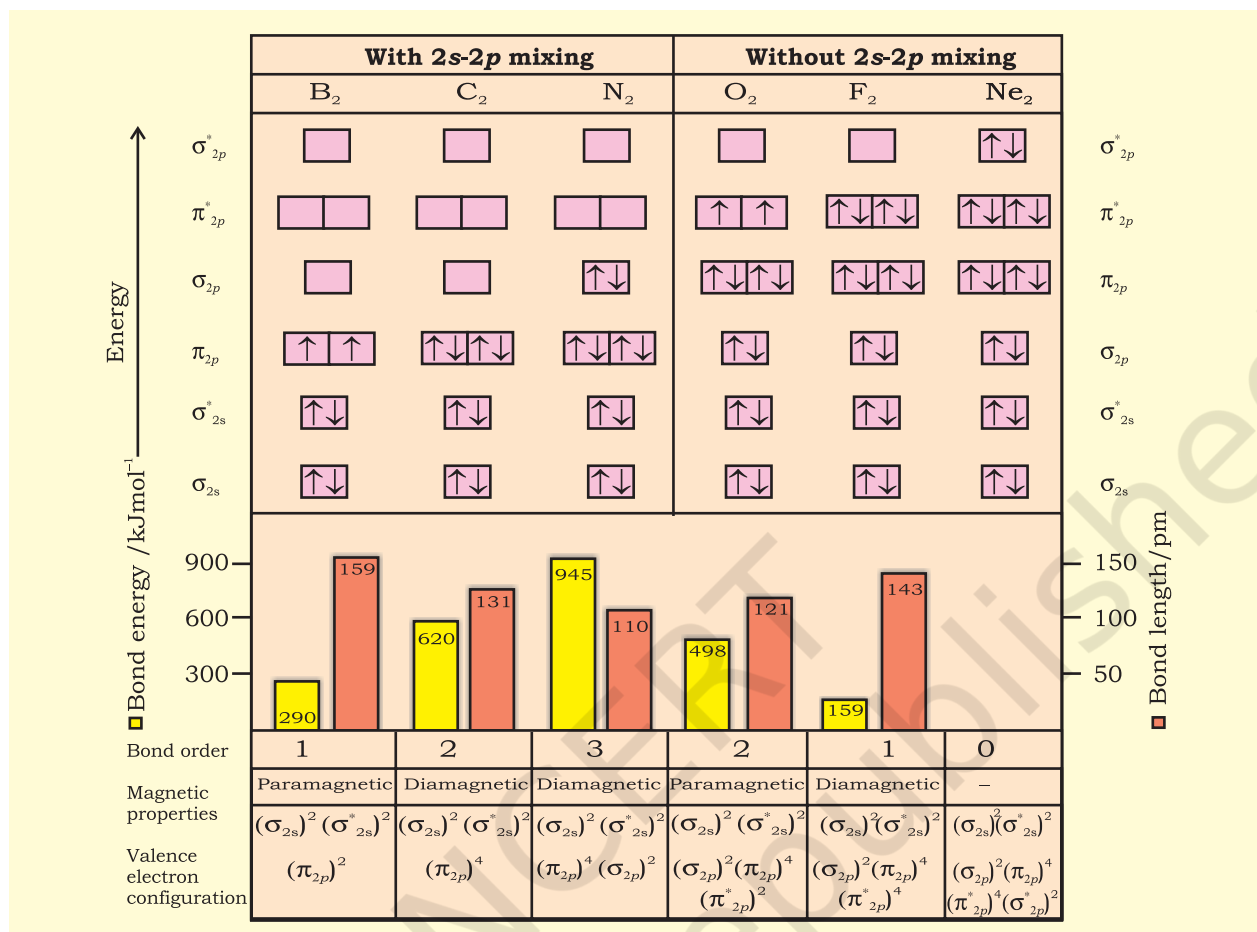
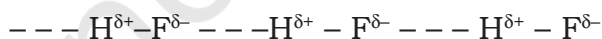

Fig. 4.21 MO occupancy and molecular properties for B₂ through Ne₂.

4.9 HYDROGEN BONDING

Nitrogen, oxygen and fluorine are the highly electronegative elements. When they are attached to a hydrogen atom to form covalent bond, the electrons of the covalent bond are shifted towards the more electronegative atom. This partially positively charged hydrogen atom forms a bond with the other more electronegative atom. This bond is known as hydrogen bond and is weaker than the covalent bond. For example, in HF molecule, the hydrogen bond exists between hydrogen atom of one molecule and fluorine atom of another molecule as depicted below :



Here, hydrogen bond acts as a bridge between two atoms which holds one atom by covalent bond and the other by hydrogen bond.

Hydrogen bond is represented by a dotted line (---) while a solid line represents the covalent bond. **Thus, hydrogen bond can be defined as the attractive force which binds hydrogen atom of one molecule with the electronegative atom (F, O or N) of another molecule.**

4.9.1 Cause of Formation of Hydrogen Bond

When hydrogen is bonded to strongly electronegative element 'X', the electron pair shared between the two atoms moves far away from hydrogen atom. As a result the hydrogen atom becomes highly electropositive with respect to the other atom 'X'. Since there is displacement of electrons towards X, the hydrogen acquires fractional positive charge (δ⁺) while 'X' attain fractional negative

charge (δ^-). This results in the formation of a polar molecule having electrostatic force of attraction which can be represented as:

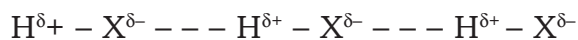

The magnitude of H-bonding depends on the physical state of the compound. It is maximum in the solid state and minimum in the gaseous state. Thus, the hydrogen bonds have strong influence on the structure and properties of the compounds.

4.9.2 Types of H-Bonds

There are two types of H-bonds

- (i) Intermolecular hydrogen bond
- (ii) Intramolecular hydrogen bond

(1) Intermolecular hydrogen bond : It is formed between two different molecules of the same or different compounds. For example,

H-bond in case of HF molecule, alcohol or water molecules, etc.

(2) Intramolecular hydrogen bond : It is formed when hydrogen atom is in between the two highly electronegative (F, O, N) atoms present within the same molecule. For example, in *o*-nitrophenol the hydrogen is in between the two oxygen atoms.

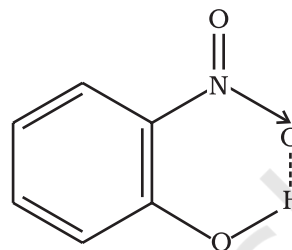

Fig. 4.22 Intramolecular hydrogen bonding in *o*-nitrophenol molecule

SUMMARY

Kössel's first insight into the mechanism of formation of electropositive and electronegative ions related the process to the attainment of noble gas configurations by the respective ions. Electrostatic attraction between ions is the cause for their stability. This gives the concept of **electrovalency**.

The first description of **covalent bonding** was provided by Lewis in terms of the sharing of electron pairs between atoms and he related the process to the attainment of noble gas configurations by reacting atoms as a result of sharing of electrons. The Lewis dot symbols show the number of valence electrons of the atoms of a given element and Lewis dot structures show pictorial representations of bonding in molecules.

An ionic compound is pictured as a three-dimensional aggregation of positive and negative ions in an ordered arrangement called the crystal lattice. In a crystalline solid there is a charge balance between the positive and negative ions. The crystal lattice is stabilized by the **enthalpy of lattice formation**.

While a single covalent bond is formed by sharing of an electron pair between two atoms, multiple bonds result from the sharing of two or three electron pairs. Some bonded atoms have additional pairs of electrons not involved in bonding. These are called lone-pairs of electrons. A Lewis dot structure shows the arrangement of bonded pairs and lone pairs around each atom in a molecule. **Important parameters, associated with chemical bonds, like: bond length, bond angle, bond enthalpy, bond order and bond polarity have significant effect on the properties of compounds.**

A number of molecules and polyatomic ions cannot be described accurately by a single Lewis structure and a number of descriptions (representations) based on the same skeletal structure are written and these taken together represent the molecule or ion. This is a very important and extremely useful concept called **resonance**. The contributing structures or *canonical forms* taken together constitute the resonance hybrid which represents the molecule or ion.

The **VSEPR model** used for predicting the geometrical shapes of molecules is based on the assumption that electron pairs repel each other and, therefore, tend to remain as far apart as possible. According to this model, *molecular geometry is determined by repulsions between lone pairs and lone pairs; lone pairs and bonding pairs and bonding pairs and bonding pairs*. The order of these repulsions being : lp-lp > lp-bp > bp-bp

The **valence bond (VB) approach** to covalent bonding is basically concerned with the energetics of covalent bond formation about which the Lewis and VSEPR models are silent. Basically the VB theory discusses bond formation in terms of overlap of orbitals. For example the formation of the H₂ molecule from two hydrogen atoms involves the overlap of the 1s orbitals of the two H atoms which are singly occupied. It is seen that the potential energy of the system gets lowered as the two H atoms come near to each other. At the equilibrium inter-nuclear distance (bond distance) the energy touches a minimum. Any attempt to bring the nuclei still closer results in a sudden increase in energy and consequent destabilization of the molecule. Because of orbital overlap the electron density between the nuclei increases which helps in bringing them closer. It is however seen that the actual bond enthalpy and bond length values are not obtained by overlap alone and other variables have to be taken into account.

For explaining the characteristic shapes of polyatomic molecules Pauling introduced the concept of **hybridisation of atomic orbitals**. *sp*, *sp*², *sp*³ hybridizations of atomic orbitals of Be, B, C, N and O are used to explain the formation and geometrical shapes of molecules like BeCl₂, BCl₃, CH₄, NH₃ and H₂O. They also explain the formation of multiple bonds in molecules like C₂H₂ and C₂H₄.

The **molecular orbital (MO) theory** describes bonding in terms of the combination and arrangement of atomic orbitals to form molecular orbitals that are associated with the molecule as a whole. The number of molecular orbitals are always equal to the number of atomic orbitals from which they are formed. Bonding molecular orbitals increase electron density between the nuclei and are lower in energy than the individual atomic orbitals. Antibonding molecular orbitals have a region of zero electron density between the nuclei and have more energy than the individual atomic orbitals.

The electronic configuration of the molecules is written by filling electrons in the molecular orbitals in the order of increasing energy levels. As in the case of atoms, the Pauli exclusion principle and Hund's rule are applicable for the filling of molecular orbitals. Molecules are said to be stable if the number of electrons in bonding molecular orbitals is greater than that in antibonding molecular orbitals.

Hydrogen bond is formed when a hydrogen atom finds itself between two highly electronegative atoms such as F, O and N. It may be intermolecular (existing between two or more molecules of the same or different substances) or intramolecular (present within the same molecule). Hydrogen bonds have a powerful effect on the structure and properties of many compounds.

EXERCISES

- 4.1 Explain the formation of a chemical bond.
- 4.2 Write Lewis dot symbols for atoms of the following elements : Mg, Na, B, O, N, Br.
- 4.3 Write Lewis symbols for the following atoms and ions:
S and S²⁻; Al and Al³⁺; H and H⁻
- 4.4 Draw the Lewis structures for the following molecules and ions :
H₂S, SiCl₄, BeF₂, CO₃²⁻, HCOOH
- 4.5 Define octet rule. Write its significance and limitations.

- 4.6 Write the favourable factors for the formation of ionic bond.
- 4.7 Discuss the shape of the following molecules using the VSEPR model:
BeCl₂, BCl₃, SiCl₄, AsF₅, H₂S, PH₃
- 4.8 Although geometries of NH₃ and H₂O molecules are distorted tetrahedral, bond angle in water is less than that of ammonia. Discuss.
- 4.9 How do you express the bond strength in terms of bond order ?
- 4.10 Define the bond length.
- 4.11 Explain the important aspects of resonance with reference to the CO₃²⁻ ion.
- 4.12 H₃PO₃ can be represented by structures 1 and 2 shown below. Can these two structures be taken as the canonical forms of the resonance hybrid representing H₃PO₃ ? If not, give reasons for the same.

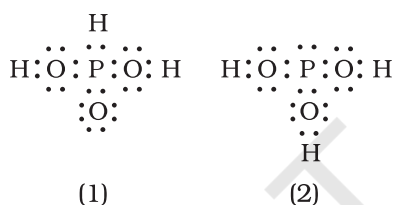

- 4.13 Write the resonance structures for SO₃, NO₂ and NO₃⁻.
- 4.14 Use Lewis symbols to show electron transfer between the following atoms to form cations and anions : (a) K and S (b) Ca and O (c) Al and N.
- 4.15 Although both CO₂ and H₂O are triatomic molecules, the shape of H₂O molecule is bent while that of CO₂ is linear. Explain this on the basis of dipole moment.
- 4.16 Write the significance/applications of dipole moment.
- 4.17 Define electronegativity. How does it differ from electron gain enthalpy ?
- 4.18 Explain with the help of suitable example polar covalent bond.
- 4.19 Arrange the bonds in order of increasing ionic character in the molecules: LiF, K₂O, N₂, SO₂ and ClF₃.
- 4.20 The skeletal structure of CH₃COOH as shown below is correct, but some of the bonds are shown incorrectly. Write the correct Lewis structure for acetic acid.

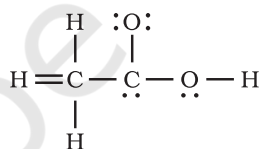

- 4.21 Apart from tetrahedral geometry, another possible geometry for CH₄ is square planar with the four H atoms at the corners of the square and the C atom at its centre. Explain why CH₄ is not square planar ?
- 4.22 Explain why BeH₂ molecule has a zero dipole moment although the Be–H bonds are polar.
- 4.23 Which out of NH₃ and NF₃ has higher dipole moment and why ?
- 4.24 What is meant by hybridisation of atomic orbitals? Describe the shapes of sp, sp², sp³ hybrid orbitals.
- 4.25 Describe the change in hybridisation (if any) of the Al atom in the following reaction.
AlCl₃ + Cl⁻ → AlCl₄⁻

- 4.26 Is there any change in the hybridisation of B and N atoms as a result of the following reaction?
$$\text{BF}_3 + \text{NH}_3 \rightarrow \text{F}_3\text{B.NH}_3$$
- 4.27 Draw diagrams showing the formation of a double bond and a triple bond between carbon atoms in C_2H_4 and C_2H_2 molecules.
- 4.28 What is the total number of sigma and pi bonds in the following molecules?
(a) C_2H_2 (b) C_2H_4
- 4.29 Considering x-axis as the internuclear axis which out of the following will not form a sigma bond and why? (a) 1s and 1s (b) 1s and $2p_x$; (c) $2p_y$ and $2p_z$ (d) 1s and 2s.
- 4.30 Which hybrid orbitals are used by carbon atoms in the following molecules?
 $\text{CH}_3\text{-CH}_3$; (b) $\text{CH}_3\text{-CH=CH}_2$; (c) $\text{CH}_3\text{-CH}_2\text{-OH}$; (d) $\text{CH}_3\text{-CHO}$ (e) CH_3COOH
- 4.31 What do you understand by bond pairs and lone pairs of electrons? Illustrate by giving one example of each type.
- 4.32 Distinguish between a sigma and a pi bond.
- 4.33 Explain the formation of H_2 molecule on the basis of valence bond theory.
- 4.34 Write the important conditions required for the linear combination of atomic orbitals to form molecular orbitals.
- 4.35 Use molecular orbital theory to explain why the Be_2 molecule does not exist.
- 4.36 Compare the relative stability of the following species and indicate their magnetic properties;
 O_2 , O_2^+ , O_2^- (superoxide), O_2^{2-} (peroxide)
- 4.37 Write the significance of a plus and a minus sign shown in representing the orbitals.
- 4.38 Describe the hybridisation in case of PCl_5 . Why are the axial bonds longer as compared to equatorial bonds?
- 4.39 Define hydrogen bond. Is it weaker or stronger than the van der Waals forces?
- 4.40 What is meant by the term bond order? Calculate the bond order of : N_2 , O_2 , O_2^+ and O_2^- .



11082CH06

UNIT 5

THERMODYNAMICS

Objectives

After studying this Unit, you will be able to

- explain the terms : system and surroundings;
- discriminate between close, open and isolated systems;
- explain internal energy, work and heat;
- state first law of thermodynamics and express it mathematically;
- calculate energy changes as work and heat contributions in chemical systems;
- explain state functions: U , H .
- correlate ΔU and ΔH ;
- measure experimentally ΔU and ΔH ;
- define standard states for ΔH ;
- calculate enthalpy changes for various types of reactions;
- state and apply Hess's law of constant heat summation;
- differentiate between extensive and intensive properties;
- define spontaneous and non-spontaneous processes;
- explain entropy as a thermodynamic state function and apply it for spontaneity;
- explain Gibbs energy change (ΔG); and
- establish relationship between ΔG and spontaneity, ΔG and equilibrium constant.

It is the only physical theory of universal content concerning which I am convinced that, within the framework of the applicability of its basic concepts, it will never be overthrown.

Albert Einstein

Chemical energy stored by molecules can be released as heat during chemical reactions when a fuel like methane, cooking gas or coal burns in air. The chemical energy may also be used to do mechanical work when a fuel burns in an engine or to provide electrical energy through a galvanic cell like dry cell. Thus, various forms of energy are interrelated and under certain conditions, these may be transformed from one form into another. The study of these energy transformations forms the subject matter of thermodynamics. The laws of thermodynamics deal with energy changes of macroscopic systems involving a large number of molecules rather than microscopic systems containing a few molecules. Thermodynamics is not concerned about how and at what rate these energy transformations are carried out, but is based on initial and final states of a system undergoing the change. Laws of thermodynamics apply only when a system is in equilibrium or moves from one equilibrium state to another equilibrium state. Macroscopic properties like pressure and temperature do not change with time for a system in equilibrium state. In this unit, we would like to answer some of the important questions through thermodynamics, like:

How do we determine the energy changes involved in a chemical reaction/process? Will it occur or not?

What drives a chemical reaction/process?

To what extent do the chemical reactions proceed?

5.1 THERMODYNAMIC TERMS

We are interested in chemical reactions and the energy changes accompanying them. For this we need to know certain thermodynamic terms. These are discussed below.

5.1.1 The System and the Surroundings

A **system** in thermodynamics refers to that part of universe in which observations are made and remaining universe constitutes the **surroundings**. The surroundings include everything other than the system. System and the surroundings together constitute the universe.

The universe = The system + The surroundings

However, the entire universe other than the system is not affected by the changes taking place in the system. Therefore, for all practical purposes, the surroundings are that portion of the remaining universe which can interact with the system. Usually, the region of space in the neighbourhood of the system constitutes its surroundings.

For example, if we are studying the reaction between two substances A and B kept in a beaker, the beaker containing the reaction mixture is the system and the room where the beaker is kept is the surroundings (Fig. 5.1).

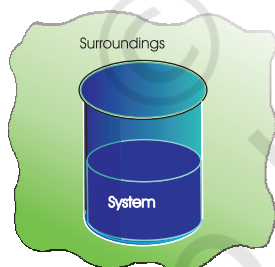

Fig. 5.1 System and the surroundings

Note that the system may be defined by physical boundaries, like beaker or test tube, or the system may simply be defined by a set of Cartesian coordinates specifying a particular volume in space. It is necessary to think of the system as separated from the surroundings by some sort of wall which may be real or imaginary. The wall that separates

the system from the surroundings is called **boundary**. This is designed to allow us to control and keep track of all movements of matter and energy in or out of the system.

5.1.2 Types of the System

We, further classify the systems according to the movements of matter and energy in or out of the system.

1. Open System

In an open system, there is exchange of energy and matter between system and surroundings [Fig. 5.2 (a)]. The presence of reactants in an open beaker is an example of an open system*. Here the boundary is an imaginary surface enclosing the beaker and reactants.

2. Closed System

In a closed system, there is no exchange of matter, but exchange of energy is possible between system and the surroundings [Fig. 5.2 (b)]. The presence of reactants in a closed vessel made of conducting material e.g., copper or steel is an example of a closed system.

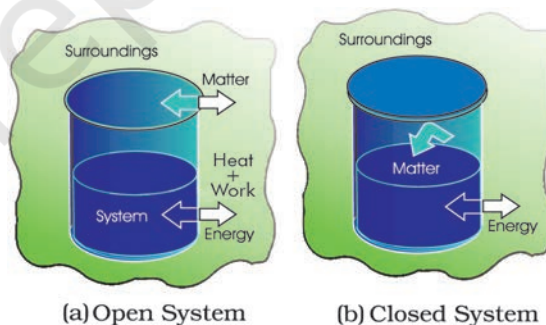

(a) Open System

(b) Closed System



(c) Isolated System

Fig. 5.2 Open, closed and isolated systems.

* We could have chosen only the reactants as system then walls of the beakers will act as boundary.

3. Isolated System

In an isolated system, there is no exchange of energy or matter between the system and the surroundings [Fig. 5.2 (c)]. The presence of reactants in a thermos flask or any other closed insulated vessel is an example of an isolated system.

5.1.3 The State of the System

The system must be described in order to make any useful calculations by specifying quantitatively each of the properties such as its pressure (p), volume (V), and temperature (T) as well as the composition of the system. We need to describe the system by specifying it before and after the change. You would recall from your Physics course that the state of a system in mechanics is completely specified at a given instant of time, by the position and velocity of each mass point of the system. In thermodynamics, a different and much simpler concept of the state of a system is introduced. It does not need detailed knowledge of motion of each particle because, we deal with average measurable properties of the system. We specify the state of the system by **state functions** or **state variables**.

The **state** of a thermodynamic system is described by its measurable or macroscopic (bulk) properties. We can describe the state of a gas by quoting its pressure (p), volume (V), temperature (T), amount (n) etc. Variables like p , V , T are called **state variables** or **state functions** because their values depend only on the state of the system and not on how it is reached. In order to completely define the state of a system it is not necessary to define all the properties of the system; as only a certain number of properties can be varied independently. This number depends on the nature of the system. Once these minimum number of macroscopic properties are fixed, others automatically have definite values.

The state of the surroundings can never be completely specified; fortunately it is not necessary to do so.

5.1.4 The Internal Energy as a State Function

When we talk about our chemical system losing or gaining energy, we need to introduce

a quantity which represents the total energy of the system. It may be chemical, electrical, mechanical or any other type of energy you may think of, the sum of all these is the energy of the system. In thermodynamics, we call it the internal energy, U of the system, which may change, when

- heat passes into or out of the system,
- work is done on or by the system,
- matter enters or leaves the system.

These systems are classified accordingly as you have already studied in section 5.1.2.

(a) Work

Let us first examine a change in internal energy by doing work. We take a system containing some quantity of water in a thermos flask or in an insulated beaker. This would not allow exchange of heat between the system and surroundings through its boundary and we call this type of system as **adiabatic**. The manner in which the state of such a system may be changed will be called adiabatic process. Adiabatic process is a process in which there is no transfer of heat between the system and surroundings. Here, the wall separating the system and the surroundings is called the adiabatic wall (Fig. 5.3).

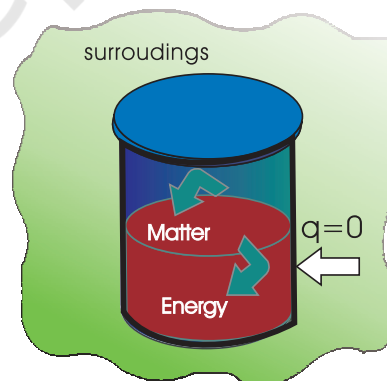

Fig. 5.3 An adiabatic system which does not permit the transfer of heat through its boundary.

Let us bring the change in the internal energy of the system by doing some work on it. Let us call the initial state of the system as state A and its temperature as T_A . Let the internal energy of the system in state A be called U_A . We can change the state of the system in two different ways.

One way: We do some mechanical work, say 1 kJ, by rotating a set of small paddles and thereby churning water. Let the new state be called B state and its temperature, as T_B . It is found that $T_B > T_A$ and the change in temperature, $\Delta T = T_B - T_A$. Let the internal energy of the system in state B be U_B and the change in internal energy, $\Delta U = U_B - U_A$.

Second way: We now do an equal amount (i.e., 1kJ) electrical work with the help of an immersion rod and note down the temperature change. We find that the change in temperature is same as in the earlier case, say, $T_B - T_A$.

In fact, the experiments in the above manner were done by J. P. Joule between 1840–50 and he was able to show that a given amount of work done on the system, no matter how it was done (irrespective of path) produced the same change of state, as measured by the change in the temperature of the system.

So, it seems appropriate to define a quantity, the internal energy U , whose value is characteristic of the state of a system, whereby the adiabatic work, w_{ad} required to bring about a change of state is equal to the difference between the value of U in one state and that in another state, ΔU i.e.,

$$\Delta U = U_2 - U_1 = w_{ad}$$

Therefore, internal energy, U , of the system is a state function.

By conventions of IUPAC in chemical thermodynamics. The positive sign expresses that w_{ad} is positive when work is done **on** the system and the internal energy of system increases. Similarly, if the work is done **by** the system, w_{ad} will be negative because internal energy of the system decreases.

Can you name some other familiar state functions? Some of other familiar state functions are V , p , and T . For example, if we bring a change in temperature of the system from 25°C to 35°C, the change in temperature is 35°C–25°C = +10°C, whether we go straight up to 35°C or we cool the system for a few degrees, then take the system to the final temperature. Thus, T is a state function and the change in temperature is independent of

the route taken. Volume of water in a pond, for example, is a state function, because change in volume of its water is independent of the route by which water is filled in the pond, either by rain or by tubewell or by both.

(b) Heat

We can also change the internal energy of a system by transfer of heat from the surroundings to the system or vice-versa without expenditure of work. This exchange of energy, which is a result of temperature difference is called heat, q . Let us consider bringing about the same change in temperature (the same initial and final states as before in section 5.1.4 (a) by transfer of heat through thermally conducting walls instead of adiabatic walls (Fig. 5.4).

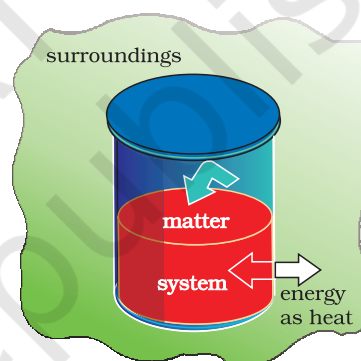

Fig. 5.4 A system which allows heat transfer through its boundary.

We take water at temperature, T_A in a container having thermally conducting walls, say made up of copper and enclose it in a huge heat reservoir at temperature, T_B . The heat absorbed by the system (water), q can be measured in terms of temperature difference, $T_B - T_A$. In this case change in internal energy, $\Delta U = q$, when no work is done at constant volume.

By conventions of IUPAC in chemical thermodynamics. The q is positive, when heat is transferred from the surroundings to the system and the internal energy of the system increases and q is negative when heat is transferred from system to the surroundings resulting in decrease of the internal energy of the system.

* Earlier negative sign was assigned when the work is done on the system and positive sign when the work is done by the system. This is still followed in physics books, although IUPAC has recommended the use of new sign convention.

(c) The general case

Let us consider the general case in which a change of state is brought about both by doing work and by transfer of heat. We write change in internal energy for this case as:

$$\Delta U = q + w \quad (5.1)$$

For a given change in state, q and w can vary depending on how the change is carried out. However, $q + w = \Delta U$ will depend only on initial and final state. It will be independent of the way the change is carried out. If there is no transfer of energy as heat or as work (isolated system) i.e., if $w = 0$ and $q = 0$, then $\Delta U = 0$.

The equation 5.1 i.e., $\Delta U = q + w$ is mathematical statement of the **first law of thermodynamics**, which states that

The energy of an isolated system is constant.

It is commonly stated as the law of conservation of energy i.e., energy can neither be created nor be destroyed.

Note: There is considerable difference between the character of the thermodynamic property energy and that of a mechanical property such as volume. We can specify an unambiguous (absolute) value for volume of a system in a particular state, but not the absolute value of the internal energy. However, we can measure only the changes in the internal energy, ΔU of the system.

Problem 5.1

Express the change in internal energy of a system when

- No heat is absorbed by the system from the surroundings, but work (w) is done on the system. What type of wall does the system have?
- No work is done on the system, but q amount of heat is taken out from the system and given to the surroundings. What type of wall does the system have?
- w amount of work is done by the system and q amount of heat is supplied to the system. What type of system would it be?

Solution

- $\Delta U = w_{ad}$, wall is adiabatic
- $\Delta U = -q$, thermally conducting walls
- $\Delta U = q - w$, closed system.

5.2 APPLICATIONS

Many chemical reactions involve the generation of gases capable of doing mechanical work or the generation of heat. It is important for us to quantify these changes and relate them to the changes in the internal energy. Let us see how!

5.2.1 Work

First of all, let us concentrate on the nature of work a system can do. We will consider only mechanical work i.e., pressure-volume work.

For understanding pressure-volume work, let us consider a cylinder which contains one mole of an ideal gas fitted with a frictionless piston. Total volume of the gas is V_i and pressure of the gas inside is p . If external pressure is p_{ex} which is greater than p , piston is moved inward till the pressure

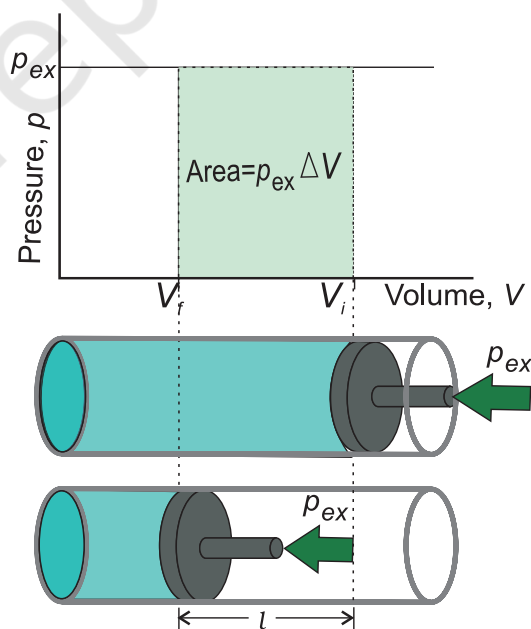

Fig. 5.5 (a) Work done on an ideal gas in a cylinder when it is compressed by a constant external pressure, p_{ex} (in single step) is equal to the shaded area.

inside becomes equal to p_{ex} . Let this change be achieved in a single step and the final volume be V_f . During this compression, suppose piston moves a distance, l and its cross-sectional area of the piston is A [Fig. 5.5(a)].

then, volume change = $l \times A = \Delta V = (V_f - V_i)$

We also know, pressure = $\frac{\text{force}}{\text{area}}$

Therefore, force on the piston = $p_{ex} \cdot A$

If w is the work done on the system by movement of the piston then

$$w = \text{force} \times \text{distance} = p_{ex} \cdot A \cdot l$$

$$= p_{ex} \cdot (-\Delta V) = -p_{ex} \Delta V = -p_{ex} (V_f - V_i) \quad (5.2)$$

The negative sign of this expression is required to obtain conventional sign for w , which will be positive. It indicates that in case of compression work is done on the system. Here $(V_f - V_i)$ will be negative and negative multiplied by negative will be positive. Hence the sign obtained for the work will be positive.

If the pressure is not constant at every stage of compression, but changes in number of finite steps, work done on the gas will be summed over all the steps and will be equal to $-\Sigma p \Delta V$ [Fig. 5.5 (b)]

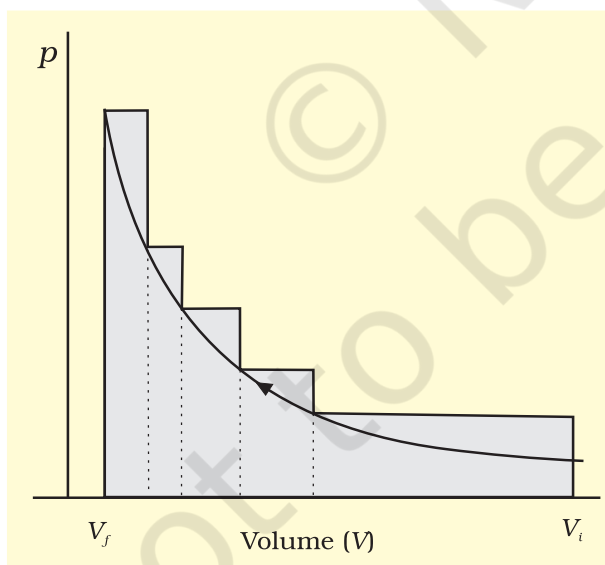

Fig. 5.5 (b) pV -plot when pressure is not constant and changes in finite steps during compression from initial volume, V_i to final volume, V_f . Work done on the gas is represented by the shaded area.

If the pressure is not constant but changes during the process such that it is always infinitesimally greater than the pressure of the gas, then, at each stage of compression, the volume decreases by an infinitesimal amount, dV . In such a case we can calculate the work done on the gas by the relation

$$w = - \int_{V_i}^{V_f} p_{ex} dV \quad (5.3)$$

Here, p_{ex} at each stage is equal to $(p_{in} + dp)$ in case of compression [Fig. 5.5(c)]. In an expansion process under similar conditions, the external pressure is always less than the pressure of the system i.e., $p_{ex} = (p_{in} - dp)$. In general case we can write, $p_{ex} = (p_{in} \pm dp)$. Such processes are called reversible processes.

A process or change is said to be reversible, if a change is brought out in such a way that the process could, at any moment, be reversed by an infinitesimal change. A reversible process proceeds infinitely slowly by a series of equilibrium states such that system and the surroundings are always in near equilibrium with each other.

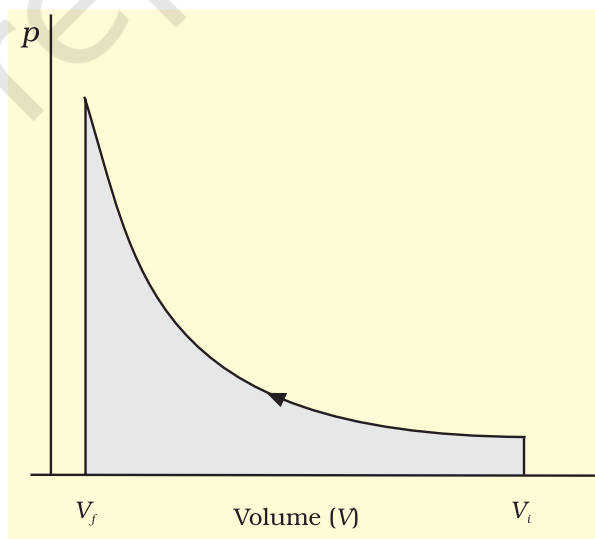

Fig. 5.5 (c) pV -plot when pressure is not constant and changes in infinite steps (reversible conditions) during compression from initial volume, V_i to final volume, V_f . Work done on the gas is represented by the shaded area.

Processes other than reversible processes are known as irreversible processes.

In chemistry, we face problems that can be solved if we relate the work term to the **internal pressure of the system**. We can relate work to internal pressure of the system under **reversible conditions** by writing equation 5.3 as follows:

$$w_{rev} = - \int_{V_i}^{V_f} p_{ex} dV = - \int_{V_i}^{V_f} (p_{in} \pm dp) dV$$

Since $dp \times dV$ is very small we can write

$$w_{rev} = - \int_{V_i}^{V_f} p_{in} dV \quad (5.4)$$

Now, the pressure of the gas (p_{in} which we can write as p now) can be expressed in terms of its volume through gas equation. For n mol of an ideal gas i.e., $pV = nRT$

$$\Rightarrow p = \frac{nRT}{V}$$

Therefore, at constant temperature (isothermal process),

$$\begin{aligned} w_{rev} &= - \int_{V_i}^{V_f} nRT \frac{dV}{V} = -nRT \ln \frac{V_f}{V_i} \\ &= -2.303 nRT \log \frac{V_f}{V_i} \quad (5.5) \end{aligned}$$

Free expansion: Expansion of a gas in vacuum ($p_{ex} = 0$) is called free expansion. No work is done during free expansion of an ideal gas whether the process is reversible or irreversible (equation 5.2 and 5.3).

Now, we can write equation 5.1 in number of ways depending on the type of processes.

Let us substitute $w = -p_{ex} \Delta V$ (eq. 5.2) in equation 5.1, and we get

$$\Delta U = q - p_{ex} \Delta V$$

If a process is carried out at constant volume ($\Delta V = 0$), then

$$\Delta U = q_v$$

the subscript v in q_v denotes that heat is supplied at constant volume.

Isothermal and free expansion of an ideal gas

For isothermal ($T = \text{constant}$) expansion of an ideal gas into vacuum; $w = 0$ since $p_{ex} = 0$. Also, Joule determined experimentally that $q = 0$; therefore, $\Delta U = 0$

Equation 5.1, $\Delta U = q + w$ can be expressed for isothermal irreversible and reversible changes as follows:

1. For isothermal irreversible change

$$q = -w = p_{ex} (V_f - V_i)$$

2. For isothermal reversible change

$$q = -w = nRT \ln \frac{V_f}{V_i}$$

$$= 2.303 nRT \log \frac{V_f}{V_i}$$

For adiabatic change, $q = 0$,

$$\Delta U = w_{ad}$$

Problem 5.2

Two litres of an ideal gas at a pressure of 10 atm expands isothermally at 25 °C into a vacuum until its total volume is 10 litres. How much heat is absorbed and how much work is done in the expansion ?

Solution

We have $q = -w = p_{ex} (10 - 2) = 0(8) = 0$
No work is done; no heat is absorbed.

Problem 5.3

Consider the same expansion, but this time against a constant external pressure of 1 atm.

Solution

We have $q = -w = p_{ex} (8) = 8$ litre-atm

Problem 5.4

Consider the expansion given in problem 5.2, for 1 mol of an ideal gas conducted reversibly.

Solution

$$\begin{aligned} \text{We have } q = -w &= 2.303 nRT \log \frac{V_f}{V_i} \\ &= 2.303 \times 1 \times 0.8206 \times 298 \times \log \frac{10}{2} \end{aligned}$$

$$\begin{aligned}
 &= 2.303 \times 0.8206 \times 298 \times \log 5 \\
 &= 2.303 \times 0.8206 \times 298 \times 0.6990 \\
 &= 393.66 \text{ L atm}
 \end{aligned}$$

5.2.2 Enthalpy, H

(a) A Useful New State Function

We know that the heat absorbed at constant volume is equal to change in the internal energy i.e., $\Delta U = q_v$. But most of chemical reactions are carried out not at constant volume, but in flasks or test tubes under constant atmospheric pressure. We need to define another state function which may be suitable under these conditions.

We may write equation (5.1) as $\Delta U = q_p - p\Delta V$ at constant pressure, where q_p is heat absorbed by the system and $-p\Delta V$ represent expansion work done by the system.

Let us represent the initial state by subscript 1 and final state by 2

We can rewrite the above equation as

$$U_2 - U_1 = q_p - p(V_2 - V_1)$$

On rearranging, we get

$$q_p = (U_2 + pV_2) - (U_1 + pV_1) \quad (5.6)$$

Now we can define another thermodynamic function, the enthalpy H [Greek word *enthalpien*, to warm or heat content] as :

$$H = U + pV \quad (5.7)$$

so, equation (5.6) becomes

$$q_p = H_2 - H_1 = \Delta H$$

Although q is a path dependent function, H is a state function because it depends on U , p and V , all of which are state functions. Therefore, ΔH is independent of path. Hence, q_p is also independent of path.

For finite changes at constant pressure, we can write equation 5.7 as

$$\Delta H = \Delta U + \Delta pV$$

Since p is constant, we can write

$$\Delta H = \Delta U + p\Delta V \quad (5.8)$$

It is important to note that when heat is absorbed by the system at constant pressure, we are actually measuring changes in the enthalpy.

Remember $\Delta H = q_p$, heat absorbed by the system at constant pressure.

ΔH is negative for exothermic reactions which evolve heat during the reaction and ΔH is positive for endothermic reactions which absorb heat from the surroundings.

At constant volume ($\Delta V = 0$), $\Delta U = q_v$, therefore equation 5.8 becomes

$$\Delta H = \Delta U = q_v$$

The difference between ΔH and ΔU is not usually significant for systems consisting of only solids and / or liquids. Solids and liquids do not suffer any significant volume changes upon heating. The difference, however, becomes significant when gases are involved. Let us consider a reaction involving gases. If V_A is the total volume of the gaseous reactants, V_B is the total volume of the gaseous products, n_A is the number of moles of gaseous reactants and n_B is the number of moles of gaseous products, all at constant pressure and temperature, then using the ideal gas law, we write,

$$pV_A = n_A RT$$

and $pV_B = n_B RT$

Thus, $pV_B - pV_A = n_B RT - n_A RT = (n_B - n_A) RT$

or $p(V_B - V_A) = (n_B - n_A) RT$

or $p \Delta V = \Delta n_g RT \quad (5.9)$

Here, Δn_g refers to the number of moles of gaseous products minus the number of moles of gaseous reactants.

Substituting the value of $p\Delta V$ from equation 5.9 in equation 5.8, we get

$$\Delta H = \Delta U + \Delta n_g RT \quad (5.10)$$

The equation 5.10 is useful for calculating ΔH from ΔU and *vice versa*.

Problem 5.5

If water vapour is assumed to be a perfect gas, molar enthalpy change for vapourisation of 1 mol of water at 1 bar and 100°C is 41 kJ mol⁻¹. Calculate the internal energy change, when

1 mol of water is vapourised at 1 bar pressure and 100°C.

Solution

(i) The change $\text{H}_2\text{O} (l) \rightarrow \text{H}_2\text{O} (g)$

$$\Delta H = \Delta U + \Delta n_g RT$$

or $\Delta U = \Delta H - \Delta n_g RT$, substituting the values, we get

$$\begin{aligned} \Delta U &= 41.00 \text{ kJ mol}^{-1} - 1 \\ &\quad \times 8.3 \text{ J mol}^{-1} \text{ K}^{-1} \times 373 \text{ K} \\ &= 41.00 \text{ kJ mol}^{-1} - 3.096 \text{ kJ mol}^{-1} \\ &= 37.904 \text{ kJ mol}^{-1} \end{aligned}$$

(b) Extensive and Intensive Properties

In thermodynamics, a distinction is made between extensive properties and intensive properties. An **extensive property** is a property whose value depends on the quantity or size of matter present in the system. For example, mass, volume, internal energy, enthalpy, heat capacity, etc. are extensive properties.

Those properties which do not depend on the quantity or size of matter present are known as **intensive properties**. For example temperature, density, pressure etc. are intensive properties. A molar property, χ_m , is the value of an extensive property χ of the system for 1 mol of the substance. If n is the amount of matter, $\chi_m = \frac{\chi}{n}$ is independent of the amount of matter. Other examples are molar volume, V_m and molar heat capacity, C_m . Let us understand the distinction between extensive and intensive properties by considering a gas enclosed in a container of volume V and at temperature T [Fig. 5.6(a)]. Let us make a partition such that volume is halved, each part [Fig. 5.6 (b)] now has one half of the original volume, $\frac{V}{2}$, but the temperature will still remain the same i.e., T . It is clear that volume is an extensive property and temperature is an intensive property.

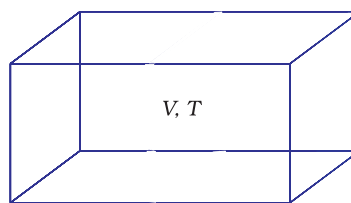

Fig. 5.6(a) A gas at volume V and temperature T

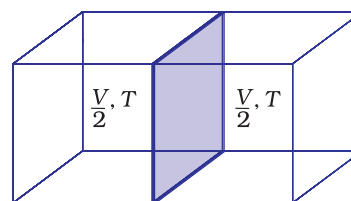

Fig. 5.6 (b) Partition, each part having half the volume of the gas

(c) Heat Capacity

In this sub-section, let us see how to measure heat transferred to a system. This heat appears as a rise in temperature of the system in case of heat absorbed by the system.

The increase of temperature is proportional to the heat transferred

$$q = \text{coeff} \times \Delta T$$

The magnitude of the coefficient depends on the size, composition and nature of the system. We can also write it as $q = C \Delta T$

The coefficient, C is called the heat capacity.

Thus, we can measure the heat supplied by monitoring the temperature rise, provided we know the heat capacity.

When C is large, a given amount of heat results in only a small temperature rise. Water has a large heat capacity i.e., a lot of energy is needed to raise its temperature.

C is directly proportional to amount of substance. The molar heat capacity of a substance, $C_m = \left(\frac{C}{n}\right)$, is the heat capacity for one mole of the substance and is the quantity of heat needed to raise the temperature of one mole by one degree celsius (or one kelvin). Specific heat, also called specific heat capacity is the quantity

of heat required to raise the temperature of one unit mass of a substance by one degree celsius (or one kelvin). For finding out the heat, q , required to raise the temperatures of a sample, we multiply the specific heat of the substance, c , by the mass m , and temperatures change, ΔT as

$$q = c \times m \times \Delta T = C \Delta T \quad (5.11)$$

(d) The Relationship between C_p and C_v for an Ideal Gas

At constant volume, the heat capacity, C is denoted by C_v and at constant pressure, this is denoted by C_p . Let us find the relationship between the two.

We can write equation for heat, q

at constant volume as $q_v = C_v \Delta T = \Delta U$

at constant pressure as $q_p = C_p \Delta T = \Delta H$

The difference between C_p and C_v can be derived for an ideal gas as:

$$\begin{aligned} \text{For a mole of an ideal gas, } \Delta H &= \Delta U + \Delta(pV) \\ &= \Delta U + \Delta(RT) \\ &= \Delta U + R\Delta T \\ \therefore \Delta H &= \Delta U + R\Delta T \quad (5.12) \end{aligned}$$

On putting the values of ΔH and ΔU , we have

$$\begin{aligned} C_p \Delta T &= C_v \Delta T + R\Delta T \\ C_p &= C_v + R \\ C_p - C_v &= R \quad (5.13) \end{aligned}$$

5.3 MEASUREMENT OF ΔU AND ΔH : CALORIMETRY

We can measure energy changes associated with chemical or physical processes by an experimental technique called calorimetry. In calorimetry, the process is carried out in a vessel called calorimeter, which is immersed in a known volume of a liquid. Knowing the heat capacity of the liquid in which calorimeter is immersed and the heat capacity of calorimeter, it is possible to determine the heat evolved in the process by measuring temperature changes. Measurements are made under two different conditions:

- i) at constant volume, q_v
- ii) at constant pressure, q_p

(a) ΔU Measurements

For chemical reactions, heat absorbed at constant volume, is measured in a bomb calorimeter (Fig. 5.7). Here, a steel vessel (the bomb) is immersed in a water bath. The whole device is called calorimeter. The steel vessel is immersed in water bath to ensure that no heat is lost to the surroundings. A combustible

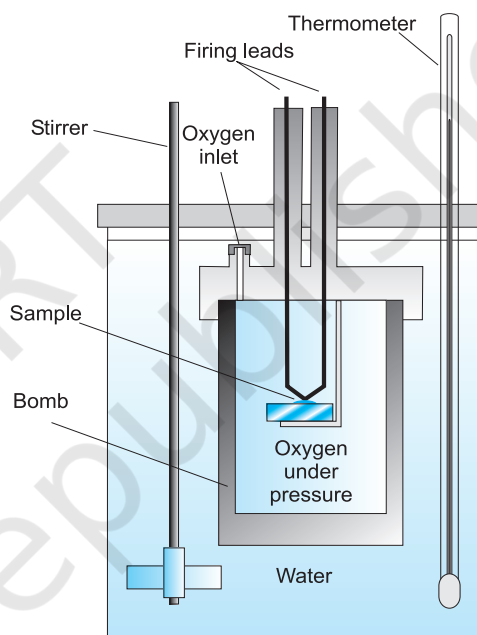

Fig. 5.7 Bomb calorimeter

substance is burnt in pure dioxygen supplied in the steel bomb. Heat evolved during the reaction is transferred to the water around the bomb and its temperature is monitored. Since the bomb calorimeter is sealed, its volume does not change i.e., the energy changes associated with reactions are measured at constant volume. Under these conditions, no work is done as the reaction is carried out at constant volume in the bomb calorimeter. Even for reactions involving gases, there is no work done as $\Delta V = 0$. Temperature change of the calorimeter produced by the completed reaction is then converted to q_v , by using the known heat capacity of the calorimeter with the help of equation 5.11.

(B) ΔH Measurements

Measurement of heat change at constant pressure (generally under atmospheric pressure) can be done in a calorimeter shown in Fig. 5.8. We know that $\Delta H = q_p$ (at constant p) and, therefore, heat absorbed or evolved, q_p at constant pressure is also called the heat of reaction or enthalpy of reaction, $\Delta_r H$.

In an exothermic reaction, heat is evolved, and system loses heat to the surroundings. Therefore, q_p will be negative and $\Delta_r H$ will also be negative. Similarly in an endothermic reaction, heat is absorbed, q_p is positive and $\Delta_r H$ will be positive.

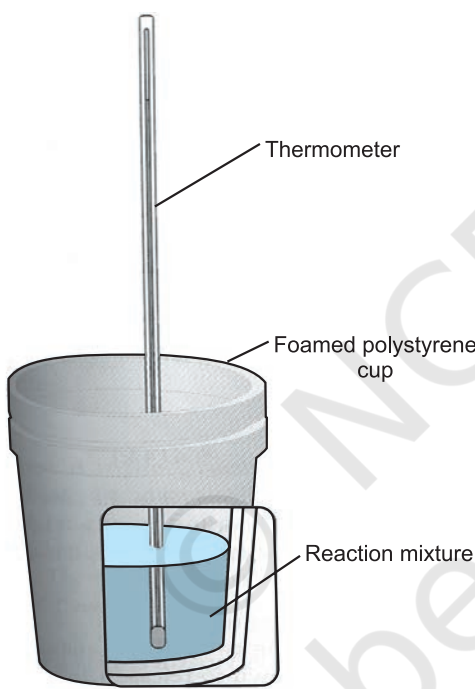

Fig. 5.8 Calorimeter for measuring heat changes at constant pressure (atmospheric pressure).

Problem 5.6

1g of graphite is burnt in a bomb calorimeter in excess of oxygen at 298 K and 1 atmospheric pressure according to the equation



During the reaction, temperature rises from 298 K to 299 K. If the heat capacity

of the bomb calorimeter is 20.7 kJ/K, what is the enthalpy change for the above reaction at 298 K and 1 atm?

Solution

Suppose q is the quantity of heat from the reaction mixture and C_V is the heat capacity of the calorimeter, then the quantity of heat absorbed by the calorimeter.

$$q = C_V \times \Delta T$$

Quantity of heat from the reaction will have the same magnitude but opposite sign because the heat lost by the system (reaction mixture) is equal to the heat gained by the calorimeter.

$$q = -C_V \times \Delta T = -20.7 \text{ kJ/K} \times (299 - 298) \text{ K} = -20.7 \text{ kJ}$$

(Here, negative sign indicates the exothermic nature of the reaction)

Thus, ΔU for the combustion of the 1g of graphite = -20.7 kJ K^{-1}

For combustion of 1 mol of graphite,

$$= \frac{12.0 \text{ g mol}^{-1} \times (-20.7 \text{ kJ})}{1 \text{ g}}$$

$$= -2.48 \times 10^2 \text{ kJ mol}^{-1}, \quad \text{Since } \Delta n_g = 0, \\ \Delta H = \Delta U = -2.48 \times 10^2 \text{ kJ mol}^{-1}$$

5.4 ENTHALPY CHANGE, $\Delta_r H$ OF A REACTION – REACTION ENTHALPY

In a chemical reaction, reactants are converted into products and is represented by,



The enthalpy change accompanying a reaction is called the **reaction enthalpy**. The enthalpy change of a chemical reaction, is given by the symbol $\Delta_r H$

$\Delta_r H =$ (sum of enthalpies of products) – (sum of enthalpies of reactants)

$$= \sum_i a_i H_{\text{products}} - \sum_i b_i H_{\text{reactants}} \quad (5.14)$$

Here symbol \sum (sigma) is used for summation and a_i and b_i are the stoichiometric

coefficients of the products and reactants respectively in the balanced chemical equation. For example, for the reaction

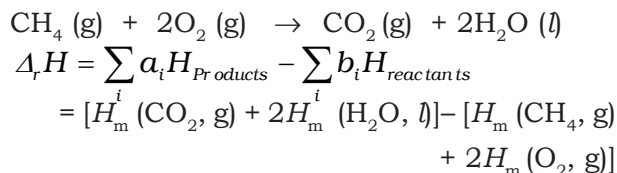

where H_m is the molar enthalpy.

Enthalpy change is a very useful quantity. Knowledge of this quantity is required when one needs to plan the heating or cooling required to maintain an industrial chemical reaction at constant temperature. It is also required to calculate temperature dependence of equilibrium constant.

(a) Standard Enthalpy of Reactions

Enthalpy of a reaction depends on the conditions under which a reaction is carried out. It is, therefore, necessary that we must specify some standard conditions.

The standard enthalpy of reaction is the enthalpy change for a reaction when all the participating substances are in their standard states.

The standard state of a substance at a specified temperature is its pure form at 1 bar. For example, the standard state of liquid

ethanol at 298 K is pure liquid ethanol at 1 bar; standard state of solid iron at 500 K is pure iron at 1 bar. Usually data are taken at 298 K.

Standard conditions are denoted by adding the superscript \ominus to the symbol ΔH , e.g., ΔH^\ominus

(b) Enthalpy Changes during Phase Transformations

Phase transformations also involve energy changes. Ice, for example, requires heat for melting. Normally this melting takes place at constant pressure (atmospheric pressure) and during phase change, temperature remains constant (at 273 K).



Here $\Delta_{\text{fus}} H^\ominus$ is enthalpy of fusion in standard state. If water freezes, then process is reversed and equal amount of heat is given off to the surroundings.

The enthalpy change that accompanies melting of one mole of a solid substance in standard state is called standard enthalpy of fusion or molar enthalpy of fusion, $\Delta_{\text{fus}} H^\ominus$.

Melting of a solid is endothermic, so all enthalpies of fusion are positive. Water

Table 5.1 Standard Enthalpy Changes of Fusion and Vaporisation

Substance	T_f/K	$\Delta_{\text{fus}} H^\ominus/(\text{kJ mol}^{-1})$	T_b/K	$\Delta_{\text{vap}} H^\ominus/(\text{kJ mol}^{-1})$
N_2	63.15	0.72	77.35	5.59
NH_3	195.40	5.65	239.73	23.35
HCl	159.0	1.992	188.0	16.15
CO	68.0	6.836	82.0	6.04
CH_3COCH_3	177.8	5.72	329.4	29.1
CCl_4	250.16	2.5	349.69	30.0
H_2O	273.15	6.01	373.15	40.79
NaCl	1081.0	28.8	1665.0	170.0
C_6H_6	278.65	9.83	353.25	30.8

(T_f and T_b are melting and boiling points, respectively)

Table 5.2 Standard Molar Enthalpies of Formation ($\Delta_f H^\ominus$) at 298K of a Few Selected Substances

Substance	$\Delta_f H^\ominus / (\text{kJ mol}^{-1})$	Substance	$\Delta_f H^\ominus / (\text{kJ mol}^{-1})$
Al ₂ O ₃ (s)	-1675.7	HI(g)	+26.48
BaCO ₃ (s)	-1216.3	KCl(s)	-436.75
Br ₂ (l)	0	KBr(s)	-393.8
Br ₂ (g)	+30.91	MgO(s)	-601.70
CaCO ₃ (s)	-1206.92	Mg(OH) ₂ (s)	-924.54
C (diamond)	+1.89	NaF(s)	-573.65
C (graphite)	0	NaCl(s)	-411.15
CaO(s)	-635.09	NaBr(s)	-361.06
CH ₄ (g)	-74.81	NaI(s)	-287.78
C ₂ H ₄ (g)	52.26	NH ₃ (g)	-46.11
CH ₃ OH(l)	-238.86	NO(g)	+90.25
C ₂ H ₅ OH(l)	-277.69	NO ₂ (g)	+33.18
C ₆ H ₆ (l)	+49.0	PCl ₃ (l)	-319.70
CO(g)	-110.53	PCl ₅ (s)	-443.5
CO ₂ (g)	-393.51	SiO ₂ (s) (quartz)	-910.94
C ₂ H ₆ (g)	-84.68	SnCl ₂ (s)	-325.1
Cl ₂ (g)	0	SnCl ₄ (l)	-511.3
C ₃ H ₈ (g)	-103.85	SO ₂ (g)	-296.83
n-C ₄ H ₁₀ (g)	-126.15	SO ₃ (g)	-395.72
HgS(s) red	-58.2	SiH ₄ (g)	+34
H ₂ (g)	0	SiCl ₄ (g)	-657.0
H ₂ O(g)	-241.82	C(g)	+716.68
H ₂ O(l)	-285.83	H(g)	+217.97
HF(g)	-271.1	Cl(g)	+121.68
HCl(g)	-92.31	Fe ₂ O ₃ (s)	-824.2
HBr(g)	-36.40		

Therefore,

$$\Delta H = -7.56 \text{ kJ mol}^{-1} + (-6.00 \text{ kJ mol}^{-1}) \\ = -13.56 \text{ kJ mol}^{-1}$$

There is negligible change in the volume during the change from liquid to solid state.

$$\text{Therefore, } p\Delta v = \Delta n_g RT = 0 \\ \Delta H = \Delta U = -13.56 \text{ kJ mol}^{-1}$$

(c) Standard Enthalpy of Formation

The standard enthalpy change for the formation of one mole of a compound from its elements in their most stable states

of aggregation (also known as reference states) is called Standard Molar Enthalpy of Formation. Its symbol is $\Delta_f H^\ominus$, where the subscript 'f' indicates that one mole of the compound in question has been formed in its standard state from its elements in their most stable states of aggregation. The reference state of an element is its most stable state of aggregation at 25°C and 1 bar pressure. For example, the reference state of dihydrogen is H₂ gas and those of dioxygen, carbon and sulphur are O₂ gas, C_{graphite} and S_{rhombic} respectively. Some reactions with standard molar enthalpies of formation are as follows.

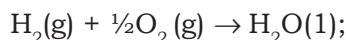

$$\Delta_f H^\ominus = -285.8 \text{ kJ mol}^{-1}$$

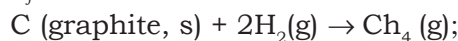

$$\Delta_f H^\ominus = -74.81 \text{ kJ mol}^{-1}$$

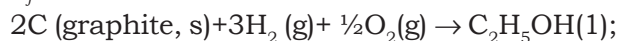

$$\Delta_f H^\ominus = -277.7 \text{ kJ mol}^{-1}$$

It is important to understand that a standard molar enthalpy of formation, $\Delta_f H^\ominus$, is just a special case of $\Delta_r H^\ominus$, where one mole of a compound is formed from its constituent elements, as in the above three equations, where 1 mol of each, water, methane and ethanol is formed. In contrast, the enthalpy change for an exothermic reaction:

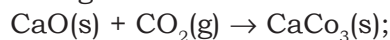

$$\Delta_r H^\ominus = -178.3 \text{ kJ mol}^{-1}$$

is not an enthalpy of formation of calcium carbonate, since calcium carbonate has been formed from other compounds, and not from its constituent elements. Also, for the reaction given below, enthalpy change is not standard enthalpy of formation, $\Delta_f H^\ominus$ for HBr(g).

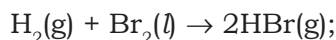

$$\Delta_r H^\ominus = -178.3 \text{ kJ mol}^{-1}$$

Here two moles, instead of one mole of the product is formed from the elements, i.e.,

$$\Delta_r H^\ominus = 2\Delta_f H^\ominus$$

Therefore, by dividing all coefficients in the balanced equation by 2, expression for enthalpy of formation of HBr (g) is written as $\frac{1}{2}\text{H}_2(\text{g}) + \frac{1}{2}\text{Br}_2(\text{l}) \rightarrow \text{HBr}(\text{g});$

$$\Delta_f H^\ominus = -36.4 \text{ kJ mol}^{-1}$$

Standard enthalpies of formation of some common substances are given in Table 5.2.

By convention, standard enthalpy for formation, $\Delta_f H^\ominus$, of an element in reference state, i.e., its most stable state of aggregation is taken as zero.

Suppose, you are a chemical engineer and want to know how much heat is required to decompose calcium carbonate to lime and carbon dioxide, with all the substances in their standard state.

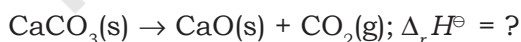

Here, we can make use of standard enthalpy of formation and calculate the enthalpy change for the reaction. The following general equation can be used for the enthalpy change calculation.

$$\Delta_r H^\ominus = \sum_i a_i \Delta_f H^\ominus(\text{products}) - \sum_i b_i \Delta_f H^\ominus(\text{reactants}) \quad (5.15)$$

where a and b represent the coefficients of the products and reactants in the balanced equation. Let us apply the above equation for decomposition of calcium carbonate. Here, coefficients 'a' and 'b' are 1 each. Therefore,

$$\begin{aligned} \Delta_r H^\ominus &= \Delta_f H^\ominus = [\text{CaO}(\text{s})] + \Delta_f H^\ominus [\text{CO}_2(\text{g})] \\ &\quad - \Delta_f H^\ominus = [\text{CaCO}_3(\text{s})] \\ &= 1(-635.1 \text{ kJ mol}^{-1}) + 1(-393.5 \text{ kJ mol}^{-1}) \\ &\quad - 1(-1206.9 \text{ kJ mol}^{-1}) \\ &= 178.3 \text{ kJ mol}^{-1} \end{aligned}$$

Thus, the decomposition of $\text{CaCO}_3(\text{s})$ is an endothermic process and you have to heat it for getting the desired products.

(d) Thermochemical Equations

A balanced chemical equation together with the value of its $\Delta_r H$ is called a thermochemical equation. We specify the physical state (alongwith allotropic state) of the substance in an equation. For example:

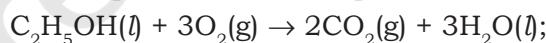

$$\Delta_r H^\ominus = -1367 \text{ kJ mol}^{-1}$$

The above equation describes the combustion of liquid ethanol at constant temperature and pressure. The negative sign of enthalpy change indicates that this is an exothermic reaction.

It would be necessary to remember the following conventions regarding thermochemical equations.

1. The coefficients in a balanced thermochemical equation refer to the number of moles (never molecules) of reactants and products involved in the reaction.
2. The numerical value of $\Delta_r H^\ominus$ refers to the number of moles of substances specified by an equation. Standard enthalpy change $\Delta_r H^\ominus$ will have units as kJ mol^{-1} .

To illustrate the concept, let us consider the calculation of heat of reaction for the following reaction :

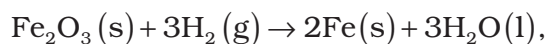

From the Table (5.2) of standard enthalpy of formation ($\Delta_f H^\ominus$), we find :

$$\Delta_f H^\ominus (\text{H}_2\text{O}, \text{l}) = -285.83 \text{ kJ mol}^{-1};$$

$$\Delta_f H^\ominus (\text{Fe}_2\text{O}_3, \text{s}) = -824.2 \text{ kJ mol}^{-1};$$

$$\text{Also } \Delta_f H^\ominus (\text{Fe}, \text{s}) = 0 \text{ and}$$

$$\Delta_f H^\ominus (\text{H}_2, \text{g}) = 0 \text{ as per convention}$$

Then,

$$\begin{aligned} \Delta_r H_1^\ominus &= 3(-285.83 \text{ kJ mol}^{-1}) \\ &\quad - 1(-824.2 \text{ kJ mol}^{-1}) \\ &= (-857.5 + 824.2) \text{ kJ mol}^{-1} \\ &= -33.3 \text{ kJ mol}^{-1} \end{aligned}$$

Note that the coefficients used in these calculations are pure numbers, which are equal to the respective stoichiometric coefficients. The unit for $\Delta_r H^\ominus$ is kJ mol^{-1} , which means *per mole of reaction*. Once we balance the chemical equation in a particular way, as above, this defines the *mole of reaction*. If we had balanced the equation differently, for example,

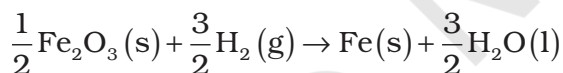

then this amount of reaction would be one mole of reaction and $\Delta_r H^\ominus$ would be

$$\begin{aligned} \Delta_r H_2^\ominus &= \frac{3}{2}(-285.83 \text{ kJ mol}^{-1}) \\ &\quad - \frac{1}{2}(-824.2 \text{ kJ mol}^{-1}) \\ &= (-428.7 + 412.1) \text{ kJ mol}^{-1} \\ &= -16.6 \text{ kJ mol}^{-1} = \frac{1}{2} \Delta_r H_1^\ominus \end{aligned}$$

It shows that enthalpy is an extensive quantity.

3. When a chemical equation is reversed, the value of $\Delta_r H^\ominus$ is reversed in sign. For example

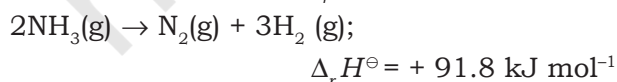
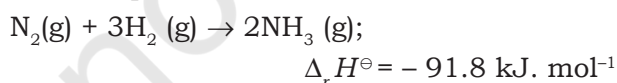

(e) Hess's Law of Constant Heat Summation

We know that enthalpy is a state function, therefore the change in enthalpy is independent of the path between initial state (reactants) and final state (products). In other words, enthalpy change for a reaction is the same whether it occurs in one step or in a series of steps. This may be stated as follows in the form of Hess's Law.

If a reaction takes place in several steps then its standard reaction enthalpy is the sum of the standard enthalpies of the intermediate reactions into which the overall reaction may be divided at the same temperature.

Let us understand the importance of this law with the help of an example.

Consider the enthalpy change for the reaction

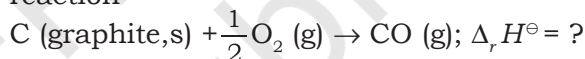

Although CO(g) is the major product, some CO₂ gas is always produced in this reaction. Therefore, we cannot measure enthalpy change for the above reaction directly. However, if we can find some other reactions involving related species, it is possible to calculate the enthalpy change for the above reaction.

Let us consider the following reactions:

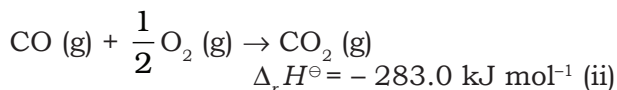
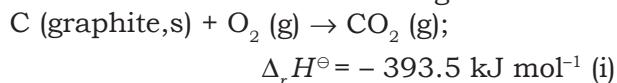

We can combine the above two reactions in such a way so as to obtain the desired reaction. To get one mole of CO(g) on the right, we reverse equation (ii). In this, heat is absorbed instead of being released, so we change sign of $\Delta_r H^\ominus$ value

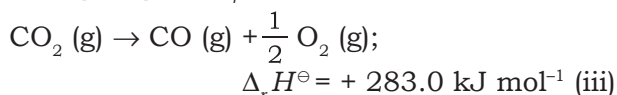

Adding equation (i) and (iii), we get the desired equation,

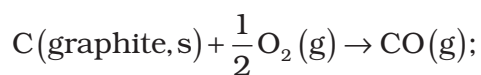

$$\begin{aligned} \text{for which } \Delta_r H^\ominus &= (-393.5 + 283.0) \\ &= -110.5 \text{ kJ mol}^{-1} \end{aligned}$$

In general, if enthalpy of an overall reaction $\text{A} \rightarrow \text{B}$ along one route is $\Delta_r H$ and $\Delta_r H_1, \Delta_r H_2, \Delta_r H_3, \dots$ representing enthalpies of reactions leading to same product, B along another route, then we have

$$\Delta_r H = \Delta_r H_1 + \Delta_r H_2 + \Delta_r H_3 \dots \quad (5.16)$$

It can be represented as:

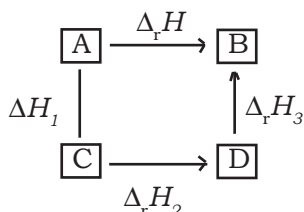

5.5 ENTHALPIES FOR DIFFERENT TYPES OF REACTIONS

It is convenient to give name to enthalpies specifying the types of reactions.

(a) Standard Enthalpy of Combustion (symbol : $\Delta_c H^\ominus$)

Combustion reactions are exothermic in nature. These are important in industry, rocketry, and other walks of life. Standard enthalpy of combustion is defined as the enthalpy change per mole (or per unit amount) of a substance, when it undergoes combustion and all the **reactants and products** being in their standard states at the specified temperature.

Cooking gas in cylinders contains mostly butane (C_4H_{10}). During complete combustion of one mole of butane, 2658 kJ of heat is released. We can write the thermochemical reactions for this as:

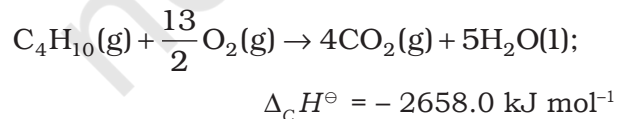

Similarly, combustion of glucose gives out 2802.0 kJ/mol of heat, for which the overall equation is :

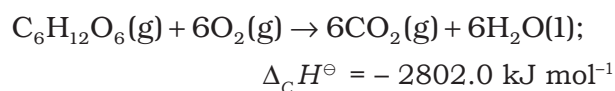

Our body also generates energy from food by the same overall process as combustion, although the final products are produced after a series of complex bio-chemical reactions involving enzymes.

Problem 5.9

The combustion of one mole of benzene takes place at 298 K and 1 atm. After combustion, $\text{CO}_2(\text{g})$ and $\text{H}_2\text{O}(\text{l})$ are produced and 3267.0 kJ of heat is liberated. Calculate the standard enthalpy of formation, $\Delta_f H^\ominus$ of benzene. Standard enthalpies of formation of $\text{CO}_2(\text{g})$ and $\text{H}_2\text{O}(\text{l})$ are $-393.5 \text{ kJ mol}^{-1}$ and $-285.83 \text{ kJ mol}^{-1}$ respectively.

Solution

The formation reaction of benzene is given by :

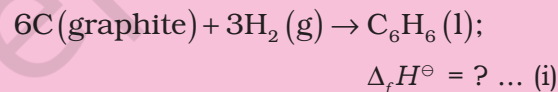

The enthalpy of combustion of 1 mol of benzene is :

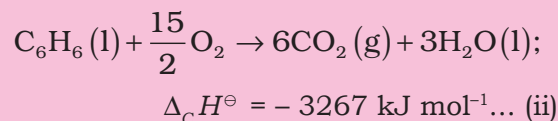

The enthalpy of formation of 1 mol of $\text{CO}_2(\text{g})$:

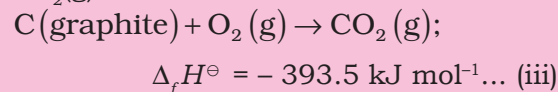

The enthalpy of formation of 1 mol of $\text{H}_2\text{O}(\text{l})$ is :

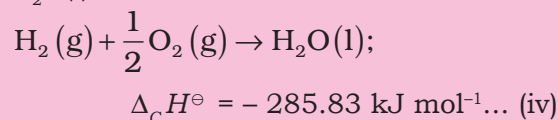

multiplying eqn. (iii) by 6 and eqn. (iv) by 3 we get:

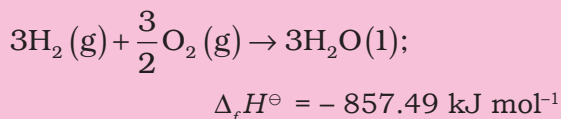
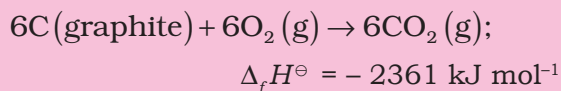

Summing up the above two equations :

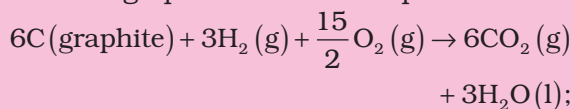

$$\Delta_f H^\ominus = -3218.49 \text{ kJ mol}^{-1} \dots \text{(v)}$$

Reversing equation (ii);

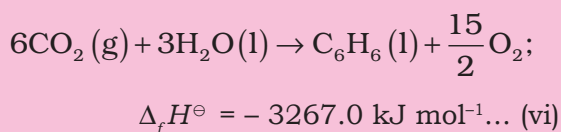

Adding equations (v) and (vi), we get

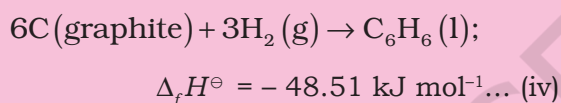

(b) Enthalpy of Atomization (symbol: $\Delta_a H^\ominus$)

Consider the following example of atomization of dihydrogen



You can see that H atoms are formed by breaking H-H bonds in dihydrogen. The enthalpy change in this process is known as enthalpy of atomization, $\Delta_a H^\ominus$. It is the enthalpy change on breaking one mole of bonds completely to obtain atoms in the gas phase.

In case of diatomic molecules, like dihydrogen (given above), the enthalpy of atomization is also the bond dissociation enthalpy. The other examples of enthalpy of atomization can be

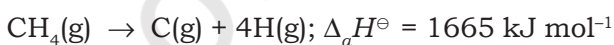

Note that the products are only **atoms** of C and H in gaseous phase. Now see the following reaction;



In this case, the enthalpy of atomization is same as the enthalpy of sublimation.

(c) Bond Enthalpy (symbol: $\Delta_{\text{bond}} H^\ominus$)

Chemical reactions involve the breaking and making of chemical bonds. Energy is required to break a bond and energy is released when a bond is formed. It is possible to relate heat of reaction to changes in energy associated with breaking and making of chemical bonds. With reference to the enthalpy changes associated with chemical bonds, two different terms are used in thermodynamics.

- (i) Bond dissociation enthalpy
- (ii) Mean bond enthalpy

Let us discuss these terms with reference to diatomic and polyatomic molecules.

Diatomic Molecules: Consider the following process in which the bonds in one mole of dihydrogen gas (H_2) are broken:

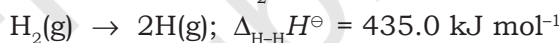

The enthalpy change involved in this process is the bond dissociation enthalpy of H-H bond. The bond dissociation enthalpy is the change in enthalpy when one mole of covalent bonds of a gaseous covalent compound is broken to form products in the gas phase.

Note that it is the same as the enthalpy of atomization of dihydrogen. This is true for all diatomic molecules. For example:

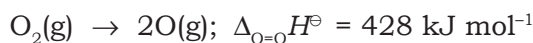

In the case of polyatomic molecules, bond dissociation enthalpy is different for different bonds within the same molecule.

Polyatomic Molecules: Let us now consider a polyatomic molecule like methane, CH_4 . The overall thermochemical equation for its atomization reaction is given below:

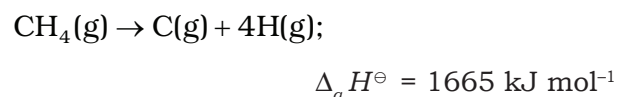

In methane, all the four C - H bonds are identical in bond length and energy. However, the energies required to break the individual C - H bonds in each successive step differ :

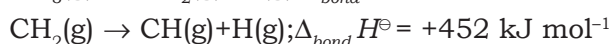
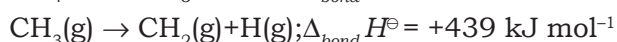
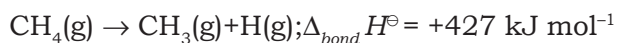

Therefore,

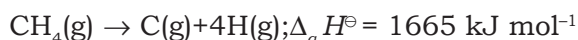

In such cases we use **mean bond enthalpy of C – H bond**.

For example in CH_4 , $\Delta_{\text{C-H}} H^\ominus$ is calculated as:

$$\begin{aligned} \Delta_{\text{C-H}} H^\ominus &= \frac{1}{4} (\Delta_a H^\ominus) = \frac{1}{4} (1665 \text{ kJ mol}^{-1}) \\ &= 416 \text{ kJ mol}^{-1} \end{aligned}$$

We find that mean C–H bond enthalpy in methane is 416 kJ/mol. It has been found that mean C–H bond enthalpies differ slightly from compound to compound, as in $\text{CH}_3\text{CH}_2\text{Cl}$, CH_3NO_2 , etc., but it does not differ in a great deal*. Using Hess's law, bond enthalpies can be calculated. Bond enthalpy values of some single and multiple bonds are

given in Table 5.3. The reaction enthalpies are very important quantities as these arise from the changes that accompany the breaking of old bonds and formation of the new bonds. We can predict enthalpy of a reaction in gas phase, if we know different bond enthalpies. The standard enthalpy of reaction, $\Delta_r H^\ominus$ is related to bond enthalpies of the reactants and products in gas phase reactions as:

$$\Delta_r H^\ominus = \sum \text{bond enthalpies}_{\text{reactants}} - \sum \text{bond enthalpies}_{\text{products}} \quad (5.17)**$$

This relationship is particularly more useful when the required values of $\Delta_f H^\ominus$ are not available. The net enthalpy change of a reaction is the amount of energy required to break all the bonds in the reactant molecules minus the amount of energy required to break all the bonds in the product molecules. Remember that this relationship is approximate and is valid when all substances

Table 5.3(a) Some Mean Single Bond Enthalpies in kJ mol⁻¹ at 298 K

H	C	N	O	F	Si	P	S	Cl	Br	I	
435.8	414	389	464	569	293	318	339	431	368	297	H
	347	293	351	439	289	264	259	330	276	238	C
		159	201	272	-	209	-	201	243	-	N
			138	184	368	351	-	205	-	201	O
				155	540	490	327	255	197	-	F
					176	213	226	360	289	213	Si
						213	230	331	272	213	P
							213	251	213	-	S
								243	218	209	Cl
									192	180	Br
										151	I

Table 5.3(b) Some Mean Multiple Bond Enthalpies in kJ mol⁻¹ at 298 K

N = N	418	C = C	611	O = O	498
N ≡ N	946	C ≡ C	837		
C = N	615	C = O	741		
C ≡ N	891	C ≡ O	1070		

* Note that symbol used for bond dissociation enthalpy and mean bond enthalpy is the same.

** If we use enthalpy of bond formation, ($\Delta_f H^\ominus_{\text{bond}}$), which is the enthalpy change when one mole of a particular type of bond is formed from gaseous atom, then $\Delta_r H^\ominus = \sum \Delta_f H^\ominus_{\text{bonds of products}} - \sum \Delta_f H^\ominus_{\text{bonds of reactants}}$

(reactants and products) in the reaction are in gaseous state.

(d) Lattice Enthalpy

The lattice enthalpy of an ionic compound is the enthalpy change which occurs when one mole of an ionic compound dissociates into its ions in gaseous state.



$$\Delta_{\text{lattice}} H^\ominus = +788 \text{ kJ mol}^{-1}$$

Since it is impossible to determine lattice enthalpies directly by experiment, we use an indirect method where we construct an enthalpy diagram called a **Born-Haber Cycle** (Fig. 5.9).

Let us now calculate the lattice enthalpy of $\text{Na}^+\text{Cl}^-(\text{s})$ by following steps given below :

1. $\text{Na}(\text{s}) \rightarrow \text{Na}(\text{g})$, *sublimation of sodium metal*, $\Delta_{\text{sub}} H^\ominus = 108.4 \text{ kJ mol}^{-1}$

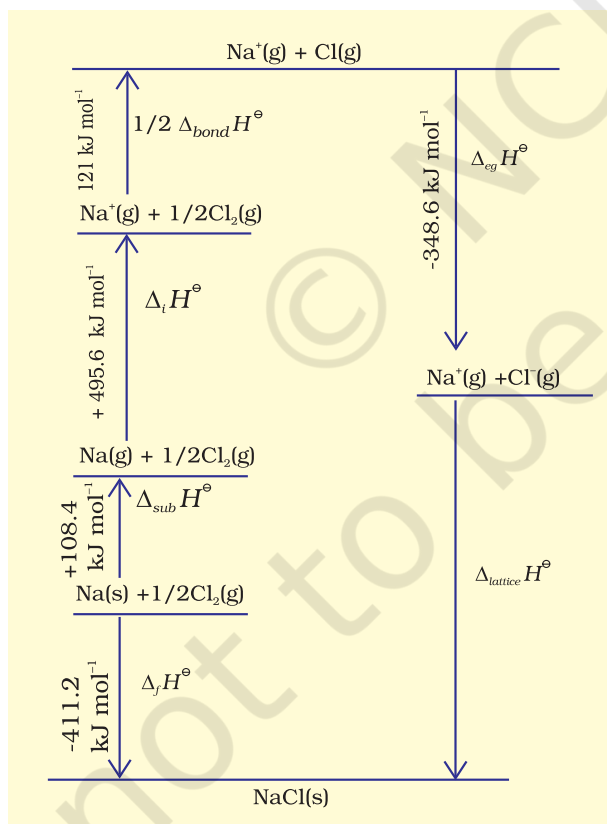

Fig. 5.9 Enthalpy diagram for lattice enthalpy of NaCl

2. $\text{Na}(\text{g}) \rightarrow \text{Na}^+(\text{g}) + \text{e}^-(\text{g})$, the *ionization of sodium atoms*, ionization enthalpy $\Delta_i H^\ominus = 496 \text{ kJ mol}^{-1}$
3. $\frac{1}{2} \text{Cl}_2(\text{g}) \rightarrow \text{Cl}(\text{g})$, the *dissociation of chlorine*, the reaction enthalpy is half the bond dissociation enthalpy. $\frac{1}{2} \Delta_{\text{bond}} H^\ominus = 121 \text{ kJ mol}^{-1}$
4. $\text{Cl}(\text{g}) + \text{e}^-(\text{g}) \rightarrow \text{Cl}^-(\text{g})$ *electron gained* by chlorine atoms. The electron gain enthalpy, $\Delta_{\text{eg}} H^\ominus = -348.6 \text{ kJ mol}^{-1}$. You have learnt about ionization enthalpy and electron gain enthalpy in Unit 3. In fact, these terms have been taken from thermodynamics. Earlier terms, ionization energy and electron affinity were in practice in place of the above terms (see the box for justification).

Ionization Energy and Electron Affinity

Ionization energy and electron affinity are defined at absolute zero. At any other temperature, heat capacities for the reactants and the products have to be taken into account. Enthalpies of reactions for

$$\text{M}(\text{g}) \rightarrow \text{M}^+(\text{g}) + \text{e}^- \quad (\text{for ionization})$$

$$\text{M}(\text{g}) + \text{e}^- \rightarrow \text{M}^-(\text{g}) \quad (\text{for electron gain})$$

at temperature, T is

$$\Delta_r H^\ominus(T) = \Delta_r H^\ominus(0) + \int_0^T \Delta_r C_p^\ominus dT$$

The value of C_p for each species in the above reaction is $5/2 R$ ($C_v = 3/2 R$)

So, $\Delta_r C_p^\ominus = +5/2 R$ (for ionization)

$\Delta_r C_p^\ominus = -5/2 R$ (for electron gain)

Therefore,

$$\Delta_r H^\ominus (\text{ionization enthalpy}) = E_0 (\text{ionization energy}) + 5/2 RT$$

$$\Delta_r H^\ominus (\text{electron gain enthalpy}) = -A (\text{electron affinity}) - 5/2 RT$$

5. $\text{Na}^+(\text{g}) + \text{Cl}^-(\text{g}) \rightarrow \text{Na}^+\text{Cl}^-(\text{s})$
The sequence of steps is shown in Fig. 5.9, and is known as a Born-Haber

cycle. The importance of the cycle is that, the sum of the enthalpy changes round a cycle is zero. Applying Hess's law, we get,

$$\Delta_{\text{lattice}} H^{\ominus} = 411.2 + 108.4 + 121 + 496 - 348.6$$

$$\Delta_{\text{lattice}} H^{\ominus} = + 788 \text{ kJ}$$

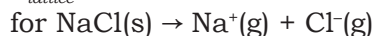

Internal energy is smaller by $2RT$ (because $\Delta n_g = 2$) and is equal to $+ 783 \text{ kJ mol}^{-1}$.

Now we use the value of lattice enthalpy to calculate enthalpy of solution from the expression:

$$\Delta_{\text{sol}} H^{\ominus} = \Delta_{\text{lattice}} H^{\ominus} + \Delta_{\text{hyd}} H^{\ominus}$$

For one mole of NaCl(s),

lattice enthalpy = $+ 788 \text{ kJ mol}^{-1}$

and $\Delta_{\text{hyd}} H^{\ominus} = - 784 \text{ kJ mol}^{-1}$ (from the literature)

$$\begin{aligned} \Delta_{\text{sol}} H^{\ominus} &= + 788 \text{ kJ mol}^{-1} - 784 \text{ kJ mol}^{-1} \\ &= + 4 \text{ kJ mol}^{-1} \end{aligned}$$

The dissolution of NaCl(s) is accompanied by very little heat change.

(e) Enthalpy of Solution (symbol : $\Delta_{\text{sol}} H^{\ominus}$)

Enthalpy of solution of a substance is the enthalpy change when one mole of it dissolves in a specified amount of solvent. The enthalpy of solution at infinite dilution is the enthalpy change observed on dissolving the substance in an infinite amount of solvent when the interactions between the ions (or solute molecules) are negligible.

When an ionic compound dissolves in a solvent, the ions leave their ordered positions on the crystal lattice. These are now more free in solution. But solvation of these ions (hydration in case solvent is water) also occurs at the same time. This is shown diagrammatically, for an ionic compound, AB (s)

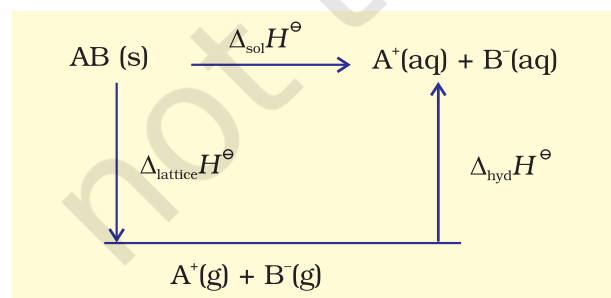

The enthalpy of solution of AB(s), $\Delta_{\text{sol}} H^{\ominus}$, in water is, therefore, determined by the selective values of the lattice enthalpy, $\Delta_{\text{lattice}} H^{\ominus}$ and enthalpy of hydration of ions, $\Delta_{\text{hyd}} H^{\ominus}$ as

$$\Delta_{\text{sol}} H^{\ominus} = \Delta_{\text{lattice}} H^{\ominus} + \Delta_{\text{hyd}} H^{\ominus}$$

For most of the ionic compounds, $\Delta_{\text{sol}} H^{\ominus}$ is positive and the dissociation process is endothermic. Therefore the solubility of most salts in water increases with rise of temperature. If the lattice enthalpy is very high, the dissolution of the compound may not take place at all. Why do many fluorides tend to be less soluble than the corresponding chlorides? Estimates of the magnitudes of enthalpy changes may be made by using tables of bond energies (enthalpies) and lattice energies (enthalpies).

(f) Enthalpy of Dilution

It is known that enthalpy of solution is the enthalpy change associated with the addition of a specified amount of solute to the specified amount of solvent at a constant temperature and pressure. This argument can be applied to any solvent with slight modification. Enthalpy change for dissolving one mole of gaseous hydrogen chloride in 10 mol of water can be represented by the following equation. For convenience we will use the symbol aq. for water



$$\Delta H = -69.01 \text{ kJ / mol}$$

Let us consider the following set of enthalpy changes:

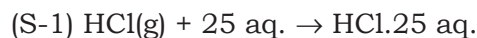

$$\Delta H = -72.03 \text{ kJ / mol}$$

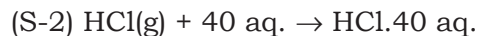

$$\Delta H = -72.79 \text{ kJ / mol}$$

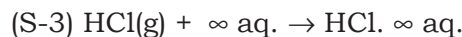

$$\Delta H = -74.85 \text{ kJ / mol}$$

The values of ΔH show general dependence of the enthalpy of solution on amount of solvent. As more and more solvent is used, the enthalpy of solution approaches a limiting value, i.e., the value in infinitely dilute solution. For hydrochloric acid this value of ΔH is given above in equation (S-3).

If we subtract the first equation (equation S-1) from the second equation (equation S-2) in the above set of equations, we obtain–

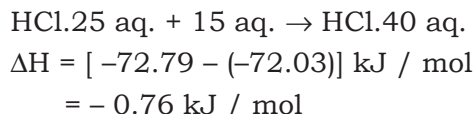

This value (–0.76kJ/mol) of ΔH is enthalpy of dilution. It is the heat withdrawn from the surroundings when additional solvent is added to the solution. The enthalpy of dilution of a solution is dependent on the original concentration of the solution and the amount of solvent added.

5.6 SPONTANEITY

The first law of thermodynamics tells us about the relationship between the heat absorbed and the work performed on or by a system. It puts no restrictions on the direction of heat flow. However, the flow of heat is unidirectional from higher temperature to lower temperature. In fact, all naturally occurring processes whether chemical or physical will tend to proceed spontaneously in one direction only. For example, a gas expanding to fill the available volume, burning carbon in dioxygen giving carbon dioxide.

But heat will not flow from colder body to warmer body on its own, the gas in a container will not spontaneously contract into one corner or carbon dioxide will not form carbon and dioxygen spontaneously. These and many other spontaneously occurring changes show unidirectional change. We may ask ‘what is the driving force of spontaneously occurring changes? What determines the direction of a spontaneous change? In this section, we shall establish some criterion for these processes whether these will take place or not.

Let us first understand what do we mean by spontaneous reaction or change? You may think by your common observation that spontaneous reaction is one which occurs immediately when contact is made between the reactants. Take the case of combination of hydrogen and oxygen. These gases may be mixed at room temperature and left for

many years without observing any perceptible change. Although the reaction is taking place between them, it is at an extremely slow rate. It is still called spontaneous reaction. So spontaneity means ‘having the potential to proceed without the assistance of external agency’. However, it does not tell about the rate of the reaction or process. Another aspect of spontaneous reaction or process, as we see is that these cannot reverse their direction on their own. We may summarise it as follows:

A spontaneous process is an irreversible process and may only be reversed by some external agency.

(a) Is Decrease in Enthalpy a Criterion for Spontaneity ?

If we examine the phenomenon like flow of water down hill or fall of a stone on to the ground, we find that there is a net decrease in potential energy in the direction of change. By analogy, we may be tempted to state that a chemical reaction is spontaneous in a given direction, because decrease in energy has taken place, as in the case of exothermic reactions. For example:

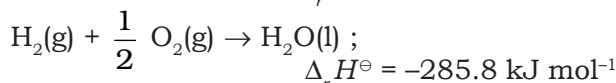
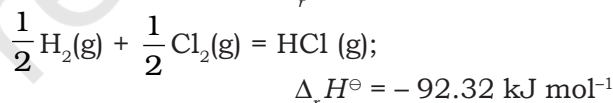
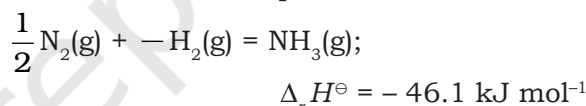

The decrease in enthalpy in passing from reactants to products may be shown for any exothermic reaction on an enthalpy diagram as shown in Fig. 5.10(a).

Thus, the postulate that driving force for a chemical reaction may be due to decrease in energy sounds ‘reasonable’ as the basis of evidence so far !

Now let us examine the following reactions:

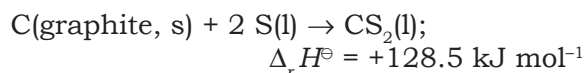
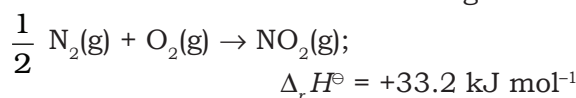

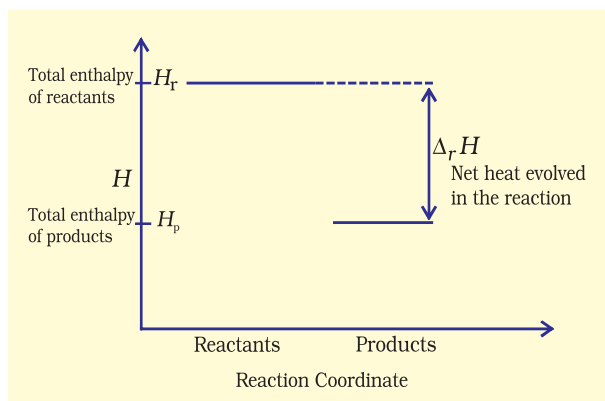

Fig. 5.10 (a) Enthalpy diagram for exothermic reactions

These reactions though endothermic, are spontaneous. The increase in enthalpy may be represented on an enthalpy diagram as shown in Fig. 5.10(b).

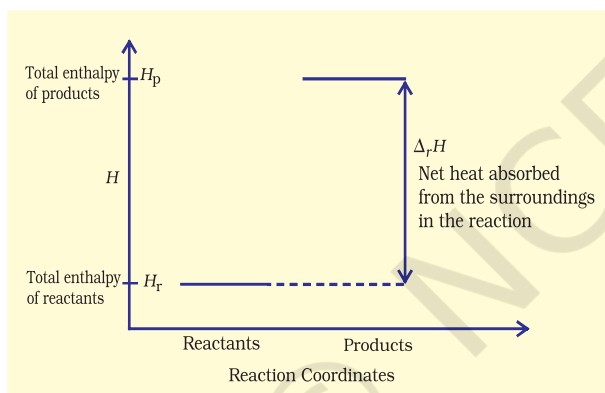

Fig. 5.10 (b) Enthalpy diagram for endothermic reactions

Therefore, it becomes obvious that while decrease in enthalpy may be a contributory factor for spontaneity, but it is not true for all cases.

(b) Entropy and Spontaneity

Then, what drives the spontaneous process in a given direction? Let us examine such a case in which $\Delta H = 0$ i.e., there is no change in enthalpy, but still the process is spontaneous.

Let us consider diffusion of two gases into each other in a closed container which is isolated from the surroundings as shown in Fig. 5.11.

The two gases, say, gas A and gas B are represented by black dots and white dots

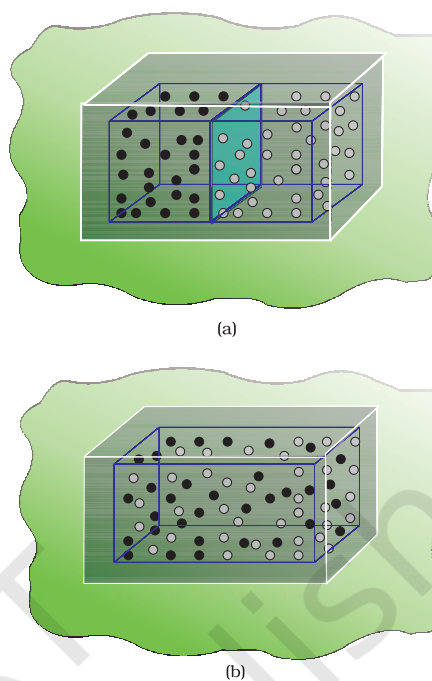

Fig. 5.11 Diffusion of two gases

respectively and separated by a movable partition [Fig. 5.11 (a)]. When the partition is withdrawn [Fig. 5.11(b)], the gases begin to diffuse into each other and after a period of time, diffusion will be complete.

Let us examine the process. Before partition, if we were to pick up the gas molecules from left container, we would be sure that these will be molecules of gas A and similarly if we were to pick up the gas molecules from right container, we would be sure that these will be molecules of gas B. But, if we were to pick up molecules from container when partition is removed, we are not sure whether the molecules picked are of gas A or gas B. We say that the system has become less predictable or more chaotic.

We may now formulate another postulate: in an isolated system, there is always a tendency for the systems' energy to become more disordered or chaotic and this could be a criterion for spontaneous change !

At this point, we introduce another thermodynamic function, **entropy** denoted as S . The above mentioned disorder is the manifestation of entropy. To form a mental

picture, one can think of entropy as a measure of the degree of randomness or disorder in the system. The greater the disorder in an isolated system, the higher is the entropy. As far as a chemical reaction is concerned, this entropy change can be attributed to rearrangement of atoms or ions from one pattern in the reactants to another (in the products). If the structure of the products is very much disordered than that of the reactants, there will be a resultant increase in entropy. The change in entropy accompanying a chemical reaction may be estimated qualitatively by a consideration of the structures of the species taking part in the reaction. Decrease of regularity in structure would mean increase in entropy. For a given substance, the crystalline solid state is the state of lowest entropy (most ordered), The gaseous state is state of highest entropy.

Now let us try to quantify entropy. One way to calculate the degree of disorder or chaotic distribution of energy among molecules would be through statistical method which is beyond the scope of this treatment. Other way would be to relate this process to the heat involved in a process which would make entropy a thermodynamic concept. Entropy, like any other thermodynamic property such as internal energy U and enthalpy H is a state function and ΔS is independent of path.

Whenever heat is added to the system, it increases molecular motions causing increased randomness in the system. Thus **heat (q) has randomising influence** on the system. Can we then equate ΔS with q ? Wait! Experience suggests us that the distribution of heat also depends on the temperature at which heat is added to the system. A system at higher temperature has greater randomness in it than one at lower temperature. Thus, **temperature is the measure of average chaotic motion of particles in the system.** Heat added to a system at lower temperature causes greater randomness than when the same quantity of heat is added to it at higher temperature. This suggests that the entropy change is inversely proportional to the temperature. ΔS is related with q and T for a reversible reaction as :

$$\Delta S = \frac{q_{rev}}{T} \quad (5.18)$$

The total entropy change (ΔS_{total}) for the system and surroundings of a spontaneous process is given by

$$\Delta S_{total} = \Delta S_{system} + \Delta S_{surr} > 0 \quad (5.19)$$

When a system is in equilibrium, the entropy is maximum, and the change in entropy, $\Delta S = 0$.

We can say that entropy for a spontaneous process increases till it reaches maximum and at equilibrium the change in entropy is zero. Since entropy is a state property, we can calculate the change in entropy of a reversible process by

$$\Delta S_{sys} = \frac{q_{sys,rev}}{T}$$

We find that both for reversible and irreversible expansion for an ideal gas, under isothermal conditions, $\Delta U = 0$, but ΔS_{total} i.e., $\Delta S_{sys} + \Delta S_{surr}$ is not zero for irreversible process. Thus, ΔU does not discriminate between reversible and irreversible process, whereas ΔS does.

Problem 5.10

Predict in which of the following, entropy increases/decreases :

- (i) A liquid crystallizes into a solid.
- (ii) Temperature of a crystalline solid is raised from 0 K to 115 K.
- (iii) $2\text{NaHCO}_3(\text{s}) \rightarrow \text{Na}_2\text{CO}_3(\text{s}) + \text{CO}_2(\text{g}) + \text{H}_2\text{O}(\text{g})$
- (iv) $\text{H}_2(\text{g}) \rightarrow 2\text{H}(\text{g})$

Solution

- (i) After freezing, the molecules attain an ordered state and therefore, entropy decreases.
- (ii) At 0 K, the constituent particles are static and entropy is minimum. If temperature is raised to 115 K, these begin to move and oscillate

about their equilibrium positions in the lattice and system becomes more disordered, therefore entropy increases.

- (iii) Reactant, NaHCO_3 is a solid and it has low entropy. Among products there are one solid and two gases. Therefore, the products represent a condition of higher entropy.
- (iv) Here one molecule gives two atoms i.e., number of particles increases leading to more disordered state. Two moles of H atoms have higher entropy than one mole of dihydrogen molecule.

Problem 5.11

For oxidation of iron,



entropy change is $-549.4 \text{ JK}^{-1} \text{ mol}^{-1}$ at 298 K. In spite of negative entropy change of this reaction, why is the reaction spontaneous?

($\Delta_r H^\ominus$ for this reaction is $-1648 \times 10^3 \text{ J mol}^{-1}$)

Solution

One decides the spontaneity of a reaction by considering

$\Delta S_{total} (\Delta S_{sys} + \Delta S_{surr})$. For calculating ΔS_{surr} , we have to consider the heat absorbed by the surroundings which is equal to $-\Delta_r H^\ominus$. At temperature T, entropy change of the surroundings is

$$\begin{aligned} \Delta S_{surr} &= -\frac{\Delta_r H^\ominus}{T} \text{ (at constant pressure)} \\ &= -\frac{(-1648 \times 10^3 \text{ J mol}^{-1})}{298 \text{ K}} \end{aligned}$$

$$= 5530 \text{ JK}^{-1} \text{ mol}^{-1}$$

Thus, total entropy change for this reaction

$$\begin{aligned} \Delta_r S_{total} &= 5530 \text{ JK}^{-1} \text{ mol}^{-1} + \\ &\quad (-549.4 \text{ JK}^{-1} \text{ mol}^{-1}) \end{aligned}$$

$$= 4980.6 \text{ JK}^{-1} \text{ mol}^{-1}$$

This shows that the above reaction is spontaneous.

(c) Gibbs Energy and Spontaneity

We have seen that for a system, it is the total entropy change, ΔS_{total} which decides the spontaneity of the process. But most of the chemical reactions fall into the category of either closed systems or open systems. Therefore, for most of the chemical reactions there are changes in both enthalpy and entropy. It is clear from the discussion in previous sections that neither decrease in enthalpy nor increase in entropy alone can determine the direction of spontaneous change for these systems.

For this purpose, we define a new thermodynamic function the Gibbs energy or Gibbs function, G, as

$$G = H - TS \quad (5.20)$$

Gibbs function, G is an extensive property and a state function.

The change in Gibbs energy for the system, ΔG_{sys} can be written as

$$\Delta G_{sys} = \Delta H_{sys} - T\Delta S_{sys} - S_{sys}\Delta T$$

At constant temperature, $\Delta T = 0$

$$\therefore \Delta G_{sys} = \Delta H_{sys} - T\Delta S_{sys}$$

Usually the subscript 'system' is dropped and we simply write this equation as

$$\Delta G = \Delta H - T\Delta S \quad (5.21)$$

Thus, Gibbs energy change = enthalpy change – temperature × entropy change, and is referred to as the Gibbs equation, one of the most important equations in chemistry. Here, we have considered both terms together for spontaneity: energy (in terms of ΔH) and entropy (ΔS , a measure of disorder) as indicated earlier. Dimensionally if we analyse, we find that ΔG has units of energy because, both ΔH and the $T\Delta S$ are energy terms, since $T\Delta S = (\text{K})(\text{J/K}) = \text{J}$.

Now let us consider how ΔG is related to reaction spontaneity.

We know,

$$\Delta S_{total} = \Delta S_{sys} + \Delta S_{surr}$$

If the system is in thermal equilibrium with the surrounding, then the temperature of the surrounding is same as that of the system. Also, increase in enthalpy of the surrounding is equal to decrease in the enthalpy of the system.

Therefore, entropy change of surroundings,

$$\Delta S_{surr} = \frac{\Delta H_{surr}}{T} = -\frac{\Delta H_{sys}}{T}$$

$$\Delta S_{total} = \Delta S_{sys} + \left(-\frac{\Delta H_{sys}}{T}\right)$$

Rearranging the above equation:

$$T\Delta S_{total} = T\Delta S_{sys} - \Delta H_{sys}$$

For spontaneous process, $\Delta S_{total} > 0$, so

$$T\Delta S_{sys} - \Delta H_{sys} > 0$$

$$\Rightarrow -(\Delta H_{sys} - T\Delta S_{sys}) > 0$$

Using equation 5.21, the above equation can be written as

$$-\Delta G > 0$$

$$\Delta G = \Delta H - T\Delta S < 0 \quad (5.22)$$

ΔH_{sys} is the enthalpy change of a reaction, $T\Delta S_{sys}$ is the energy which is not available to do useful work. So ΔG is the net energy available to do useful work and is thus a measure of the 'free energy'. For this reason, it is also known as the free energy of the reaction.

ΔG gives a criteria for spontaneity at constant pressure and temperature.

- (i) If ΔG is negative (< 0), the process is spontaneous.
- (ii) If ΔG is positive (> 0), the process is non spontaneous.

Note : If a reaction has a positive enthalpy change and positive entropy change, it can be spontaneous when $T\Delta S$ is large enough to outweigh ΔH . This can happen in two ways; (a) The positive entropy change of the system can be 'small' in which case T must be large. (b) The positive entropy change of the system can be 'large', in which case T may

be small. The former is one of the reasons why reactions are often carried out at high temperature. Table 5.4 summarises the effect of temperature on spontaneity of reactions.

(d) Entropy and Second Law of Thermodynamics

We know that for an isolated system the change in energy remains constant. Therefore, increase in entropy in such systems is the natural direction of a spontaneous change. This, in fact is the second law of thermodynamics. Like first law of thermodynamics, second law can also be stated in several ways. The second law of thermodynamics explains why spontaneous exothermic reactions are so common. In exothermic reactions heat released by the reaction increases the disorder of the surroundings and overall entropy change is positive which makes the reaction spontaneous.

(e) Absolute Entropy and Third Law of Thermodynamics

Molecules of a substance may move in a straight line in any direction, they may spin like a top and the bonds in the molecules may stretch and compress. These motions of the molecule are called translational, rotational and vibrational motion respectively. When temperature of the system rises, these motions become more vigorous and entropy increases. On the other hand when temperature is lowered, the entropy decreases. **The entropy of any pure crystalline substance approaches zero as the temperature approaches absolute zero. This is called third law of thermodynamics.** This is so because there is perfect order in a crystal at absolute zero. The statement is confined to pure crystalline solids because theoretical arguments and practical evidences have shown that entropy of solutions and super cooled liquids is not zero at 0 K. The importance of the third law lies in the fact that it permits the calculation of absolute values of entropy of pure substance from thermal data alone. For a pure substance, this can

be done by summing $\frac{q_{rev}}{T}$ increments from 0 K to 298 K. Standard entropies can be used to calculate standard entropy changes by a Hess's law type of calculation.

5.7 GIBBS ENERGY CHANGE AND EQUILIBRIUM

We have seen how a knowledge of the sign and magnitude of the free energy change of a chemical reaction allows:

- Prediction of the spontaneity of the chemical reaction.
- Prediction of the useful work that could be extracted from it.

So far we have considered free energy changes in irreversible reactions. Let us now examine the free energy changes in reversible reactions.

'Reversible' under strict thermodynamic sense is a special way of carrying out a process such that system is at all times in perfect equilibrium with its surroundings. When applied to a chemical reaction, the term 'reversible' indicates that a given reaction can proceed in either direction simultaneously, so that a dynamic equilibrium is set up. This means that the reactions in both the directions should proceed with a decrease in free energy, which seems impossible. It is possible only if at equilibrium the free energy of the system

is minimum. If it is not, the system would spontaneously change to configuration of lower free energy.

So, the criterion for equilibrium



$$\Delta_r G = 0$$

Gibbs energy for a reaction in which all reactants and products are in standard state, $\Delta_r G^\ominus$ is related to the equilibrium constant of the reaction as follows:

$$0 = \Delta_r G^\ominus + RT \ln K$$

$$\text{or } \Delta_r G^\ominus = -RT \ln K$$

$$\text{or } \Delta_r G^\ominus = -2.303 RT \log K \quad (5.23)$$

We also know that

$$\Delta_r G^\ominus = \Delta_r H^\ominus - T\Delta_r S^\ominus = -RT \ln K \quad (5.24)$$

For strongly endothermic reactions, the value of $\Delta_r H^\ominus$ may be large and positive. In such a case, value of K will be much smaller than 1 and the reaction is unlikely to form much product. In case of exothermic reactions, $\Delta_r H^\ominus$ is large and negative, and $\Delta_r G^\ominus$ is likely to be large and negative too. In such cases, K will be much larger than 1. We may expect strongly exothermic reactions to have a large K , and hence can go to near completion. $\Delta_r G^\ominus$ also depends upon $\Delta_r S^\ominus$, if the changes in the entropy of reaction is also taken into account, the value of K or extent of chemical reaction will also be affected, depending upon whether $\Delta_r S^\ominus$ is positive or negative.

Using equation (5.24),

Table 5.4 Effect of Temperature on Spontaneity of Reactions

$\Delta_r H^\ominus$	$\Delta_r S^\ominus$	$\Delta_r G^\ominus$	Description*
-	+	-	Reaction spontaneous at all temperatures
-	-	-(at low T)	Reaction spontaneous at low temperature
-	-	+(at high T)	Reaction nonspontaneous at high temperature
+	+	+(at low T)	Reaction nonspontaneous at low temperature
+	+	-(at high T)	Reaction spontaneous at high temperature
+	-	+(at all T)	Reaction nonspontaneous at all temperatures

* The term low temperature and high temperature are relative. For a particular reaction, high temperature could even mean room temperature.

- (i) It is possible to obtain an estimate of ΔG^\ominus from the measurement of ΔH^\ominus and ΔS^\ominus , and then calculate K at any temperature for economic yields of the products.
- (ii) If K is measured directly in the laboratory, value of ΔG^\ominus at any other temperature can be calculated.

Using equation (5.24),

Problem 5.12

Calculate $\Delta_r G^\ominus$ for conversion of oxygen to ozone, $3/2 \text{ O}_2(\text{g}) \rightarrow \text{O}_3(\text{g})$ at 298 K. if K_p for this conversion is 2.47×10^{-29} .

Solution

We know $\Delta_r G^\ominus = -2.303 RT \log K_p$ and $R = 8.314 \text{ JK}^{-1} \text{ mol}^{-1}$

$$\begin{aligned} \text{Therefore, } \Delta_r G^\ominus &= -2.303 (8.314 \text{ J K}^{-1} \text{ mol}^{-1}) \\ &\quad \times (298 \text{ K}) (\log 2.47 \times 10^{-29}) \\ &= 163000 \text{ J mol}^{-1} \\ &= 163 \text{ kJ mol}^{-1}. \end{aligned}$$

Problem 5.13

Find out the value of equilibrium constant for the following reaction at 298 K.

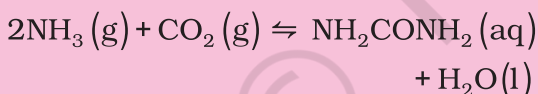

Standard Gibbs energy change, $\Delta_r G^\ominus$ at the given temperature is $-13.6 \text{ kJ mol}^{-1}$.

Solution

$$\text{We know, } \log K = \frac{-\Delta_r G^\ominus}{2.303 RT}$$

$$\begin{aligned} &= \frac{(-13.6 \times 10^3 \text{ J mol}^{-1})}{2.303 (8.314 \text{ JK}^{-1} \text{ mol}^{-1}) (298 \text{ K})} \\ &= 2.38 \end{aligned}$$

$$\text{Hence } K = \text{antilog } 2.38 = 2.4 \times 10^2.$$

Problem 5.14

At 60°C , dinitrogen tetroxide is 50 per cent dissociated. Calculate the standard free energy change at this temperature and at one atmosphere.

Solution



If N_2O_4 is 50% dissociated, the mole fraction of both the substances is given by

$$\begin{aligned} x_{\text{N}_2\text{O}_4} &= \frac{1 - 0.5}{1 + 0.5}; x_{\text{NO}_2} = \frac{2 \times 0.5}{1 + 0.5} \\ p_{\text{N}_2\text{O}_4} &= \frac{0.5}{1.5} \times 1 \text{ atm}, p_{\text{NO}_2} = \\ &\quad \frac{1}{1.5} \times 1 \text{ atm}. \end{aligned}$$

The equilibrium constant K_p is given by

$$\begin{aligned} K_p &= \frac{(p_{\text{NO}_2})^2}{p_{\text{N}_2\text{O}_4}} = \frac{1.5}{(1.5)^2 (0.5)} \\ &= 1.33 \text{ atm}. \end{aligned}$$

Since

$$\begin{aligned} \Delta_r G^\ominus &= -RT \ln K_p \\ \Delta_r G^\ominus &= (-8.314 \text{ JK}^{-1} \text{ mol}^{-1}) \times (333 \text{ K}) \\ &\quad \times (2.303) \times (0.1239) \\ &= -763.8 \text{ kJ mol}^{-1} \end{aligned}$$

SUMMARY

Thermodynamics deals with energy changes in chemical or physical processes and enables us to study these changes quantitatively and to make useful predictions. For these purposes, we divide the universe into the system and the surroundings. Chemical or physical processes lead to evolution or absorption of heat (q), part of which may be converted into work (w). These quantities are related through the **first law of thermodynamics** via $\Delta U = q + w$. ΔU , change in internal energy, depends on initial and final states only and is a state function, whereas q and w depend on the path and are not the state functions. We follow sign conventions of q and w by giving the positive sign to these quantities when these are added to the system. We can measure the transfer of heat from one system to another which causes the change in temperature. The magnitude of rise in temperature depends on the heat capacity (C) of a substance. Therefore, heat absorbed or evolved is $q = C\Delta T$. Work can be measured by $w = -p_{\text{ex}}\Delta V$, in case of expansion of gases. Under reversible process, we can put $p_{\text{ex}} = p$ for infinitesimal changes in the volume making $w_{\text{rev}} = -p\,dV$. In this condition, we can use gas equation, $pV = nRT$.

At constant volume, $w = 0$, then $\Delta U = q_v$, heat transfer at constant volume. But in study of chemical reactions, we usually have constant pressure. We define another state function **enthalpy**. Enthalpy change, $\Delta H = \Delta U + \Delta n_g RT$, can be found directly from the heat changes at constant pressure, $\Delta H = q_p$.

There are varieties of enthalpy changes. Changes of phase such as melting, vaporization and sublimation usually occur at constant temperature and can be characterized by enthalpy changes which are always positive. Enthalpy of formation, combustion and other enthalpy changes can be calculated using **Hess's law**. Enthalpy change for chemical reactions can be determined by

$$\Delta_r H = \sum_f (a_i \Delta_f H_{\text{products}}) - \sum_i (b_i \Delta_f H_{\text{reactions}})$$

and in gaseous state by

$$\Delta_r H^\ominus = \sum \text{bond enthalpies of the reactants} - \sum \text{bond enthalpies of the products}$$

First law of thermodynamics does not guide us about the direction of chemical reactions i.e., what is the driving force of a chemical reaction. For isolated systems, $\Delta U = 0$. We define another state function, S , **entropy** for this purpose. **Entropy** is a measure of disorder or randomness. For a spontaneous change, total entropy change is positive. Therefore, for an isolated system, $\Delta U = 0$, $\Delta S > 0$, so entropy change distinguishes a spontaneous change, while energy change does not. Entropy changes can be measured by the equation

$$\Delta S = \frac{q_{\text{rev}}}{T} \text{ for a reversible process. } \frac{q_{\text{rev}}}{T} \text{ is independent of path.}$$

Chemical reactions are generally carried at constant pressure, so we define another state function **Gibbs energy**, G , which is related to entropy and enthalpy changes of the system by the equation:

$$\Delta_r G = \Delta_r H - T \Delta_r S$$

For a spontaneous change, $\Delta G_{\text{sys}} < 0$ and at equilibrium, $\Delta G_{\text{sys}} = 0$.

Standard Gibbs energy change is related to equilibrium constant by

$$\Delta_r G^\ominus = -RT \ln K.$$

K can be calculated from this equation, if we know $\Delta_r G^\ominus$ which can be found from $\Delta_r G^\ominus = \Delta_r H^\ominus - T \Delta_r S^\ominus$. Temperature is an important factor in the equation. Many reactions which are non-spontaneous at low temperature, are made spontaneous at high temperature for systems having positive entropy of reaction.

EXERCISES

- 5.1 Choose the correct answer. A thermodynamic state function is a quantity
- (i) used to determine heat changes
 - (ii) whose value is independent of path
 - (iii) used to determine pressure volume work
 - (iv) whose value depends on temperature only.
- 5.2 For the process to occur under adiabatic conditions, the correct condition is:
- (i) $\Delta T = 0$
 - (ii) $\Delta p = 0$
 - (iii) $q = 0$
 - (iv) $w = 0$
- 5.3 The enthalpies of all elements in their standard states are:
- (i) unity
 - (ii) zero
 - (iii) < 0
 - (iv) different for each element
- 5.4 ΔU^\ominus of combustion of methane is $-X \text{ kJ mol}^{-1}$. The value of ΔH^\ominus is
- (i) $= \Delta U^\ominus$
 - (ii) $> \Delta U^\ominus$
 - (iii) $< \Delta U^\ominus$
 - (iv) $= 0$
- 5.5 The enthalpy of combustion of methane, graphite and dihydrogen at 298 K are, $-890.3 \text{ kJ mol}^{-1}$, $-393.5 \text{ kJ mol}^{-1}$, and $-285.8 \text{ kJ mol}^{-1}$ respectively. Enthalpy of formation of $\text{CH}_4(\text{g})$ will be
- (i) $-74.8 \text{ kJ mol}^{-1}$
 - (ii) $-52.27 \text{ kJ mol}^{-1}$
 - (iii) $+74.8 \text{ kJ mol}^{-1}$
 - (iv) $+52.26 \text{ kJ mol}^{-1}$.
- 5.6 A reaction, $\text{A} + \text{B} \rightarrow \text{C} + \text{D} + q$ is found to have a positive entropy change. The reaction will be
- (i) possible at high temperature
 - (ii) possible only at low temperature
 - (iii) not possible at any temperature
 - (v) possible at any temperature
- 5.7 In a process, 701 J of heat is absorbed by a system and 394 J of work is done by the system. What is the change in internal energy for the process?
- 5.8 The reaction of cyanamide, $\text{NH}_2\text{CN}(\text{s})$, with dioxygen was carried out in a bomb calorimeter, and ΔU was found to be $-742.7 \text{ kJ mol}^{-1}$ at 298 K. Calculate enthalpy change for the reaction at 298 K.

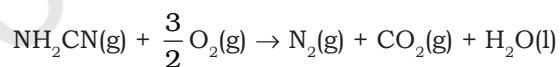

- 5.9 Calculate the number of kJ of heat necessary to raise the temperature of 60.0 g of aluminium from 35°C to 55°C. Molar heat capacity of Al is 24 J mol⁻¹ K⁻¹.
- 5.10 Calculate the enthalpy change on freezing of 1.0 mol of water at 10.0°C to ice at -10.0°C. $\Delta_{\text{fus}}H = 6.03 \text{ kJ mol}^{-1}$ at 0°C.
 $C_p [\text{H}_2\text{O}(\text{l})] = 75.3 \text{ J mol}^{-1} \text{ K}^{-1}$
 $C_p [\text{H}_2\text{O}(\text{s})] = 36.8 \text{ J mol}^{-1} \text{ K}^{-1}$
- 5.11 Enthalpy of combustion of carbon to CO₂ is -393.5 kJ mol⁻¹. Calculate the heat released upon formation of 35.2 g of CO₂ from carbon and dioxygen gas.
- 5.12 Enthalpies of formation of CO(g), CO₂(g), N₂O(g) and N₂O₄(g) are -110, -393, 81 and 9.7 kJ mol⁻¹ respectively. Find the value of $\Delta_r H$ for the reaction:
 $\text{N}_2\text{O}_4(\text{g}) + 3\text{CO}(\text{g}) \rightarrow \text{N}_2\text{O}(\text{g}) + 3\text{CO}_2(\text{g})$
- 5.13 Given
 $\text{N}_2(\text{g}) + 3\text{H}_2(\text{g}) \rightarrow 2\text{NH}_3(\text{g}); \Delta_r H^\ominus = -92.4 \text{ kJ mol}^{-1}$
 What is the standard enthalpy of formation of NH₃ gas?
- 5.14 Calculate the standard enthalpy of formation of CH₃OH(l) from the following data:
 $\text{CH}_3\text{OH}(\text{l}) + \frac{3}{2} \text{O}_2(\text{g}) \rightarrow \text{CO}_2(\text{g}) + 2\text{H}_2\text{O}(\text{l}); \Delta_r H^\ominus = -726 \text{ kJ mol}^{-1}$
 $\text{C}(\text{graphite}) + \text{O}_2(\text{g}) \rightarrow \text{CO}_2(\text{g}); \Delta_c H^\ominus = -393 \text{ kJ mol}^{-1}$
 $\text{H}_2(\text{g}) + \frac{1}{2} \text{O}_2(\text{g}) \rightarrow \text{H}_2\text{O}(\text{l}); \Delta_f H^\ominus = -286 \text{ kJ mol}^{-1}$.
- 5.15 Calculate the enthalpy change for the process
 $\text{CCl}_4(\text{g}) \rightarrow \text{C}(\text{g}) + 4 \text{Cl}(\text{g})$
 and calculate bond enthalpy of C - Cl in CCl₄(g).
 $\Delta_{\text{vap}} H^\ominus(\text{CCl}_4) = 30.5 \text{ kJ mol}^{-1}$.
 $\Delta_f H^\ominus(\text{CCl}_4) = -135.5 \text{ kJ mol}^{-1}$.
 $\Delta_a H^\ominus(\text{C}) = 715.0 \text{ kJ mol}^{-1}$, where $\Delta_a H^\ominus$ is enthalpy of atomisation
 $\Delta_a H^\ominus(\text{Cl}_2) = 242 \text{ kJ mol}^{-1}$
- 5.16 For an isolated system, $\Delta U = 0$, what will be ΔS ?
- 5.17 For the reaction at 298 K,
 $2\text{A} + \text{B} \rightarrow \text{C}$
 $\Delta H = 400 \text{ kJ mol}^{-1}$ and $\Delta S = 0.2 \text{ kJ K}^{-1} \text{ mol}^{-1}$
 At what temperature will the reaction become spontaneous considering ΔH and ΔS to be constant over the temperature range.
- 5.18 For the reaction,
 $2 \text{Cl}(\text{g}) \rightarrow \text{Cl}_2(\text{g})$, what are the signs of ΔH and ΔS ?
- 5.19 For the reaction
 $2 \text{A}(\text{g}) + \text{B}(\text{g}) \rightarrow 2\text{D}(\text{g})$
 $\Delta U^\ominus = -10.5 \text{ kJ}$ and $\Delta S^\ominus = -44.1 \text{ JK}^{-1}$.
 Calculate ΔG^\ominus for the reaction, and predict whether the reaction may occur spontaneously.

- 5.20 The equilibrium constant for a reaction is 10. What will be the value of ΔG^\ominus ?
 $R = 8.314 \text{ JK}^{-1} \text{ mol}^{-1}$, $T = 300 \text{ K}$.
- 5.21 Comment on the thermodynamic stability of $\text{NO}(\text{g})$, given
- $$\frac{1}{2} \text{N}_2(\text{g}) + \frac{1}{2} \text{O}_2(\text{g}) \rightarrow \text{NO}(\text{g}); \quad \Delta_f H^\ominus = 90 \text{ kJ mol}^{-1}$$
- $$\text{NO}(\text{g}) + \frac{1}{2} \text{O}_2(\text{g}) \rightarrow \text{NO}_2(\text{g}); \quad \Delta_f H^\ominus = -74 \text{ kJ mol}^{-1}$$
- 5.22 Calculate the entropy change in surroundings when 1.00 mol of $\text{H}_2\text{O}(\text{l})$ is formed under standard conditions. $\Delta_f H^\ominus = -286 \text{ kJ mol}^{-1}$.

© NCERT
not to be republished



11082CH07

UNIT 6

EQUILIBRIUM

Objectives

After studying this unit you will be able to

- identify dynamic nature of equilibrium involved in physical and chemical processes;
- state the law of equilibrium;
- explain characteristics of equilibria involved in physical and chemical processes;
- write expressions for equilibrium constants;
- establish a relationship between K_p and K_c ;
- explain various factors that affect the equilibrium state of a reaction;
- classify substances as acids or bases according to Arrhenius, Bronsted-Lowry and Lewis concepts;
- classify acids and bases as weak or strong in terms of their ionization constants;
- explain the dependence of degree of ionization on concentration of the electrolyte and that of the common ion;
- describe pH scale for representing hydrogen ion concentration;
- explain ionisation of water and its dual role as acid and base;
- describe ionic product (K_w) and pK_w for water;
- appreciate use of buffer solutions;
- calculate solubility product constant.

Chemical equilibria are important in numerous biological and environmental processes. For example, equilibria involving O_2 molecules and the protein hemoglobin play a crucial role in the transport and delivery of O_2 from our lungs to our muscles. Similar equilibria involving CO molecules and hemoglobin account for the toxicity of CO.

When a liquid evaporates in a closed container, molecules with relatively higher kinetic energy escape the liquid surface into the vapour phase and number of liquid molecules from the vapour phase strike the liquid surface and are retained in the liquid phase. It gives rise to a constant vapour pressure because of an *equilibrium* in which the number of molecules leaving the liquid equals the number returning to liquid from the vapour. We say that the system has reached **equilibrium state** at this stage. However, this is not static equilibrium and there is a lot of activity at the boundary between the liquid and the vapour. Thus, at *equilibrium*, the rate of evaporation is equal to the rate of condensation. It may be represented by

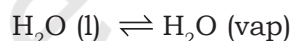

The double half arrows indicate that the processes in both the directions are going on simultaneously. The mixture of reactants and products in the equilibrium state is called an **equilibrium mixture**.

Equilibrium can be established for both physical processes and chemical reactions. The reaction may be fast or slow depending on the experimental conditions and the nature of the reactants. When the reactants in a closed vessel at a particular temperature react to give products, the concentrations of the reactants keep on decreasing, while those of products keep on increasing for some time after which there is no change in the concentrations of either of the reactants or products. This stage of the system is the **dynamic equilibrium** and the rates of the forward and reverse reactions become equal. It is due to

this dynamic equilibrium stage that there is no change in the concentrations of various species in the reaction mixture. Based on the extent to which the reactions proceed to reach the state of **chemical equilibrium**, these may be classified in three groups.

- (i) The reactions that proceed nearly to completion and only negligible concentrations of the reactants are left. In some cases, it may not be even possible to detect these experimentally.
- (ii) The reactions in which only small amounts of products are formed and most of the reactants remain unchanged at equilibrium stage.
- (iii) The reactions in which the concentrations of the reactants and products are comparable, when the system is in equilibrium.

The extent of a reaction in equilibrium varies with the experimental conditions such as concentrations of reactants, temperature, etc. Optimisation of the operational conditions is very important in industry and laboratory so that equilibrium is favorable in the direction of the desired product. Some important aspects of equilibrium involving physical and chemical processes are dealt in this unit along with the equilibrium involving ions in aqueous solutions which is called as **ionic equilibrium**.

6.1 EQUILIBRIUM IN PHYSICAL PROCESSES

The characteristics of system at equilibrium are better understood if we examine some physical processes. The most familiar examples are **phase transformation processes**, *e.g.*,

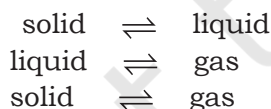

6.1.1 Solid-Liquid Equilibrium

Ice and water kept in a perfectly insulated thermos flask (no exchange of heat between its contents and the surroundings) at 273K and the atmospheric pressure are in equilibrium state and the system shows interesting

characteristic features. We observe that the mass of ice and water do not change with time and the temperature remains constant. However, the equilibrium is not static. The intense activity can be noticed at the boundary between ice and water. Molecules from the liquid water collide against ice and adhere to it and some molecules of ice escape into liquid phase. There is no change of mass of ice and water, as the rates of transfer of molecules from ice into water and of reverse transfer from water into ice are equal at atmospheric pressure and 273 K.

It is obvious that ice and water are in equilibrium only at particular temperature and pressure. *For any pure substance at atmospheric pressure, the temperature at which the solid and liquid phases are at equilibrium is called the normal melting point or normal freezing point of the substance.* The system here is in dynamic equilibrium and we can infer the following:

- (i) Both the opposing processes occur simultaneously.
- (ii) Both the processes occur at the same rate so that the amount of ice and water remains constant.

6.1.2 Liquid-Vapour Equilibrium

This equilibrium can be better understood if we consider the example of a transparent box carrying a U-tube with mercury (manometer). Drying agent like anhydrous calcium chloride (or phosphorus penta-oxide) is placed for a few hours in the box. After removing the drying agent by tilting the box on one side, a watch glass (or petri dish) containing water is quickly placed inside the box. It will be observed that the mercury level in the right limb of the manometer slowly increases and finally attains a constant value, that is, the pressure inside the box increases and reaches a constant value. Also the volume of water in the watch glass decreases (Fig. 6.1). Initially there was no water vapour (or very less) inside the box. As water evaporated the pressure in the box increased due to addition of water molecules into the gaseous phase inside the box. The rate of evaporation is constant.

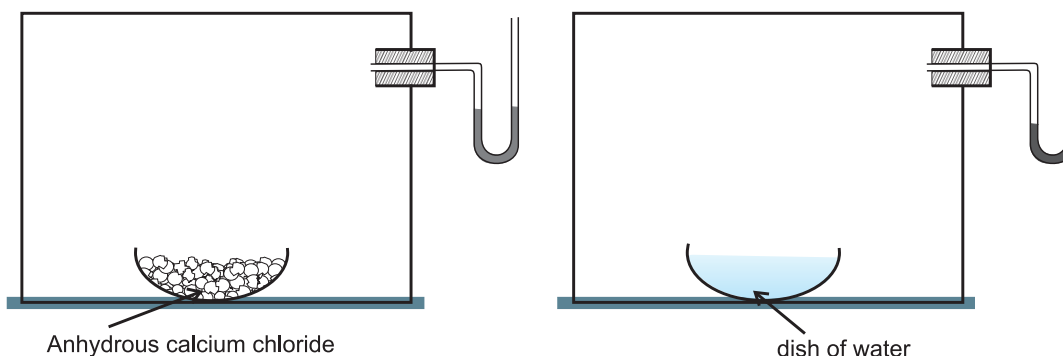
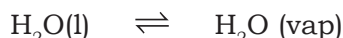

Fig. 6.1 Measuring equilibrium vapour pressure of water at a constant temperature

However, the rate of increase in pressure decreases with time due to condensation of vapour into water. Finally it leads to an equilibrium condition when there is no net evaporation. This implies that the number of water molecules from the gaseous state into the liquid state also increases till the equilibrium is attained i.e.,

rate of evaporation = rate of condensation



At equilibrium the pressure exerted by the water molecules at a given temperature remains constant and is called the equilibrium vapour pressure of water (or just vapour pressure of water); vapour pressure of water increases with temperature. If the above experiment is repeated with methyl alcohol, acetone and ether, it is observed that different liquids have different equilibrium vapour pressures at the same temperature, and the liquid which has a higher vapour pressure is more volatile and has a lower boiling point.

If we expose three watch glasses containing separately 1 mL each of acetone, ethyl alcohol, and water to atmosphere and repeat the experiment with different volumes of the liquids in a warmer room, it is observed that in all such cases the liquid eventually disappears and the time taken for complete evaporation depends on (i) the nature of the liquid, (ii) the amount of the liquid and (iii) the temperature. When the watch glass is open to the atmosphere, the rate of evaporation remains constant but the molecules are dispersed into large volume of the room. As a consequence the rate of condensation from

vapour to liquid state is much less than the rate of evaporation. These are open systems and it is not possible to reach equilibrium in an open system.

Water and water vapour are in equilibrium position at atmospheric pressure (1.013 bar) and at 100°C in a closed vessel. The boiling point of water is 100°C at 1.013 bar pressure. For any pure liquid at one atmospheric pressure (1.013 bar), the temperature at which the liquid and vapours are at equilibrium is called normal boiling point of the liquid. Boiling point of the liquid depends on the atmospheric pressure. It depends on the altitude of the place; at high altitude the boiling point decreases.

6.1.3 Solid – Vapour Equilibrium

Let us now consider the systems where solids sublime to vapour phase. If we place solid iodine in a closed vessel, after sometime the vessel gets filled up with violet vapour and the intensity of colour increases with time. After certain time the intensity of colour becomes constant and at this stage equilibrium is attained. Hence solid iodine sublimates to give iodine vapour and the iodine vapour condenses to give solid iodine. The equilibrium can be represented as,

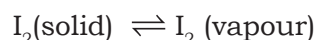

Other examples showing this kind of equilibrium are,

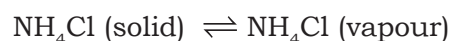
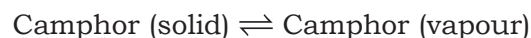

6.1.4 Equilibrium Involving Dissolution of Solid or Gases in Liquids

Solids in liquids

We know from our experience that we can dissolve only a limited amount of salt or sugar in a given amount of water at room temperature. If we make a thick sugar syrup solution by dissolving sugar at a higher temperature, sugar crystals separate out if we cool the syrup to the room temperature. We call it a saturated solution when no more of solute can be dissolved in it at a given temperature. The concentration of the solute in a saturated solution depends upon the temperature. In a saturated solution, a dynamic equilibrium exists between the solute molecules in the solid state and in the solution:

Sugar (solution) \rightleftharpoons Sugar (solid), and
the rate of dissolution of sugar = rate of crystallisation of sugar.

Equality of the two rates and dynamic nature of equilibrium has been confirmed with the help of radioactive sugar. If we drop some radioactive sugar into saturated solution of non-radioactive sugar, then after some time radioactivity is observed both in the solution and in the solid sugar. Initially there were no radioactive sugar molecules in the solution but due to dynamic nature of equilibrium, there is exchange between the radioactive and non-radioactive sugar molecules between the two phases. The ratio of the radioactive to non-radioactive molecules in the solution increases till it attains a constant value.

Gases in liquids

When a soda water bottle is opened, some of the carbon dioxide gas dissolved in it fizzes out rapidly. The phenomenon arises due to difference in solubility of carbon dioxide at different pressures. There is equilibrium between the molecules in the gaseous state and the molecules dissolved in the liquid under pressure i.e.,



This equilibrium is governed by Henry's law, **which states that the mass of a gas dissolved in a given mass of a solvent at any temperature is proportional to the**

pressure of the gas above the solvent.

This amount decreases with increase of temperature. The soda water bottle is sealed under pressure of gas when its solubility in water is high. As soon as the bottle is opened, some of the dissolved carbon dioxide gas escapes to reach a new equilibrium condition required for the lower pressure, namely its partial pressure in the atmosphere. This is how the soda water in bottle when left open to the air for some time, turns 'flat'. It can be generalised that:

- (i) For solid \rightleftharpoons liquid equilibrium, there is only one temperature (melting point) at 1 atm (1.013 bar) at which the two phases can coexist. If there is no exchange of heat with the surroundings, the mass of the two phases remains constant.
- (ii) For liquid \rightleftharpoons vapour equilibrium, the vapour pressure is constant at a given temperature.
- (iii) For dissolution of solids in liquids, the solubility is constant at a given temperature.
- (iv) For dissolution of gases in liquids, the concentration of a gas in liquid is proportional to the pressure (concentration) of the gas over the liquid. These observations are summarised in Table 6.1

Table 6.1 Some Features of Physical Equilibria

Process	Conclusion
Liquid \rightleftharpoons Vapour $\text{H}_2\text{O} (\text{l}) \rightleftharpoons \text{H}_2\text{O} (\text{g})$	$p_{\text{H}_2\text{O}}$ constant at given temperature
Solid \rightleftharpoons Liquid $\text{H}_2\text{O} (\text{s}) \rightleftharpoons \text{H}_2\text{O} (\text{l})$	Melting point is fixed at constant pressure
Solute(s) \rightleftharpoons Solute (solution) Sugar(s) \rightleftharpoons Sugar (solution)	Concentration of solute in solution is constant at a given temperature
Gas(g) \rightleftharpoons Gas (aq) $\text{CO}_2(\text{g}) \rightleftharpoons \text{CO}_2(\text{aq})$	$[\text{gas}(\text{aq})]/[\text{gas}(\text{g})]$ is constant at a given temperature $[\text{CO}_2(\text{aq})]/[\text{CO}_2(\text{g})]$ is constant at a given temperature

6.1.5 General Characteristics of Equilibria Involving Physical Processes

For the physical processes discussed above, following characteristics are common to the system at equilibrium:

- Equilibrium is possible only in a closed system at a given temperature.
- Both the opposing processes occur at the same rate and there is a dynamic but stable condition.
- All measurable properties of the system remain constant.
- When equilibrium is attained for a physical process, it is characterised by constant value of one of its parameters at a given temperature. Table 6.1 lists such quantities.
- The magnitude of such quantities at any stage indicates the extent to which the physical process has proceeded before reaching equilibrium.

6.2 EQUILIBRIUM IN CHEMICAL PROCESSES - DYNAMIC EQUILIBRIUM

Analogous to the physical systems chemical reactions also attain a state of equilibrium. These reactions can occur both in forward and backward directions. When the rates of the forward and reverse reactions become equal, the concentrations of the reactants and the products remain constant. This is the stage of chemical equilibrium. This equilibrium is *dynamic* in nature as it consists of a *forward* reaction in which the reactants give product(s) and *reverse* reaction in which product(s) gives the original reactants.

For a better comprehension, let us consider a general case of a reversible reaction,

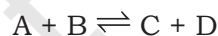

With passage of time, there is accumulation of the products C and D and depletion of the reactants A and B (Fig. 6.2). This leads to a decrease in the rate of forward reaction and an increase in the rate of the reverse reaction,

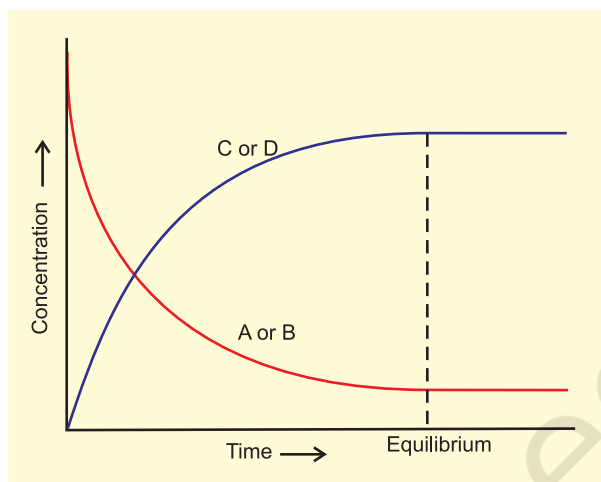

Fig. 6.2 Attainment of chemical equilibrium.

Eventually, the two reactions occur at the same rate and the system reaches a state of equilibrium.

Similarly, the reaction can reach the state of equilibrium even if we start with only C and D; that is, no A and B being present initially, as the equilibrium can be reached from either direction.

The dynamic nature of chemical equilibrium can be demonstrated in the synthesis of ammonia by Haber's process. In a series of experiments, Haber started with known amounts of dinitrogen and dihydrogen maintained at high temperature and pressure and at regular intervals determined the amount of ammonia present. He was successful in determining also the concentration of unreacted dihydrogen and dinitrogen. Fig. 6.4 (page 174) shows that after a certain time the composition of the mixture remains the same even though some of the reactants are still present. This constancy in composition indicates that the reaction has reached equilibrium. In order to understand the dynamic nature of the reaction, synthesis of ammonia is carried out with exactly the same starting conditions (of partial pressure and temperature) but using D_2 (deuterium) in place of H_2 . The reaction mixtures starting either with H_2 or D_2 reach equilibrium with the same composition, except that D_2 and ND_3 are present instead of H_2 and NH_3 . After

Dynamic Equilibrium – A Student’s Activity

Equilibrium whether in a physical or in a chemical system, is always of dynamic nature. This can be demonstrated by the use of radioactive isotopes. This is not feasible in a school laboratory. However this concept can be easily comprehended by performing the following activity. The activity can be performed in a group of 5 or 6 students.

Take two 100mL measuring cylinders (marked as 1 and 2) and two glass tubes each of 30 cm length. Diameter of the tubes may be same or different in the range of 3-5mm. Fill nearly half of the measuring cylinder-1 with coloured water (for this purpose add a crystal of potassium permanganate to water) and keep second cylinder (number 2) empty.

Put one tube in cylinder 1 and second in cylinder 2. Immerse one tube in cylinder 1, close its upper tip with a finger and transfer the coloured water contained in its lower portion to cylinder 2. Using second tube, kept in 2nd cylinder, transfer the coloured water in a similar manner from cylinder 2 to cylinder 1. In this way keep on transferring coloured water using the two glass tubes from cylinder 1 to 2 and from 2 to 1 till you notice that the level of coloured water in both the cylinders becomes constant.

If you continue intertransferring coloured solution between the cylinders, there will not be any further change in the levels of coloured water in two cylinders. If we take analogy of ‘level’ of coloured water with ‘concentration’ of reactants and products in the two cylinders, we can say the process of transfer, which continues even after the constancy of level, is indicative of dynamic nature of the process. If we repeat the experiment taking two tubes of different diameters we find that at equilibrium the level of coloured water in two cylinders is different. How far diameters are responsible for change in levels in two cylinders? Empty cylinder (2) is an indicator of no product in it at the beginning.

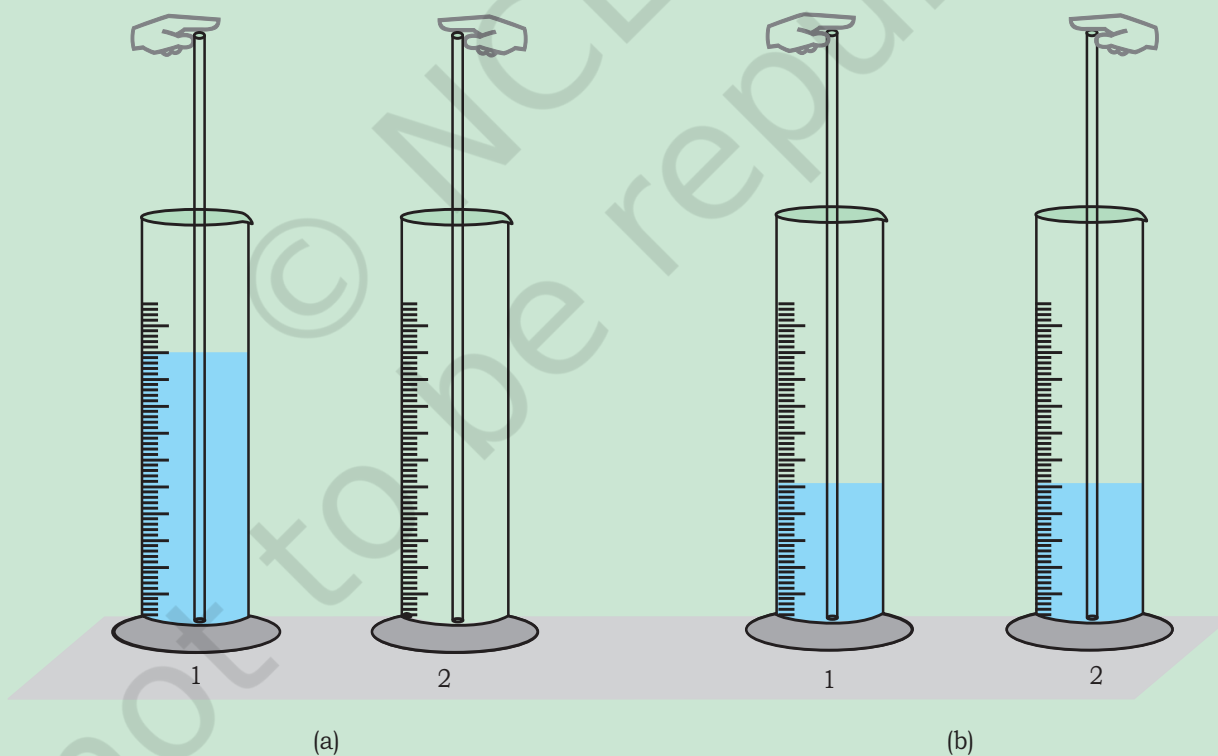

Fig. 6.3 Demonstrating dynamic nature of equilibrium. (a) initial stage (b) final stage after the equilibrium is attained.

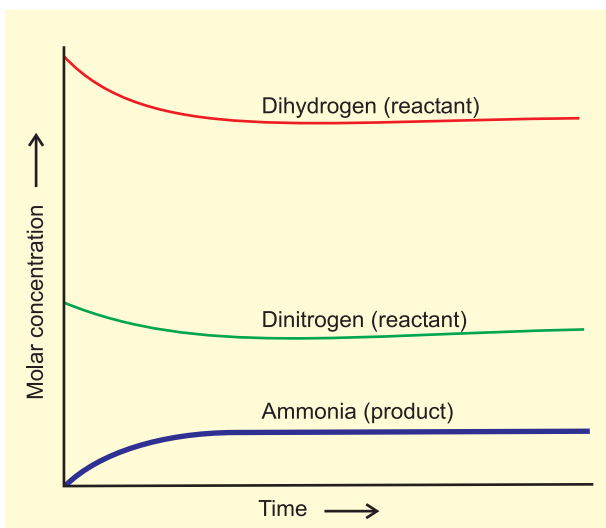
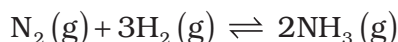

Fig. 6.4 Depiction of equilibrium for the reaction



equilibrium is attained, these two mixtures (H_2 , N_2 , NH_3 and D_2 , N_2 , ND_3) are mixed together and left for a while. Later, when this mixture is analysed, it is found that the concentration of ammonia is just the same as before. However, when this mixture is analysed by a mass spectrometer, it is found that ammonia and all deuterium containing forms of ammonia (NH_3 , NH_2D , NHD_2 and ND_3) and dihydrogen and its deuterated forms (H_2 , HD and D_2) are present. Thus one can conclude that scrambling of H and D atoms in the molecules must result from a continuation of the forward and reverse reactions in the mixture. If the reaction had simply stopped when they reached equilibrium, then there would have been no mixing of isotopes in this way.

Use of isotope (deuterium) in the formation of ammonia clearly indicates that **chemical reactions reach a state of dynamic equilibrium in which the rates of forward and reverse reactions are equal and there is no net change in composition.**

Equilibrium can be attained from both sides, whether we start reaction by taking, $\text{H}_2(\text{g})$ and $\text{N}_2(\text{g})$ and get $\text{NH}_3(\text{g})$ or by taking $\text{NH}_3(\text{g})$ and decomposing it into $\text{N}_2(\text{g})$ and $\text{H}_2(\text{g})$.

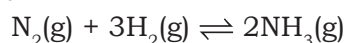

Similarly let us consider the reaction, $\text{H}_2(\text{g}) + \text{I}_2(\text{g}) \rightleftharpoons 2\text{HI}(\text{g})$. If we start with equal initial concentration of H_2 and I_2 , the reaction proceeds in the forward direction and the concentration of H_2 and I_2 decreases while that of HI increases, until all of these become constant at equilibrium (Fig. 6.5). We can also start with HI alone and make the reaction to proceed in the reverse direction; the concentration of HI will decrease and concentration of H_2 and I_2 will increase until they all become constant when equilibrium is reached (Fig. 6.5). If total number of H and I atoms are same in a given volume, the same equilibrium mixture is obtained whether we start it from pure reactants or pure product.

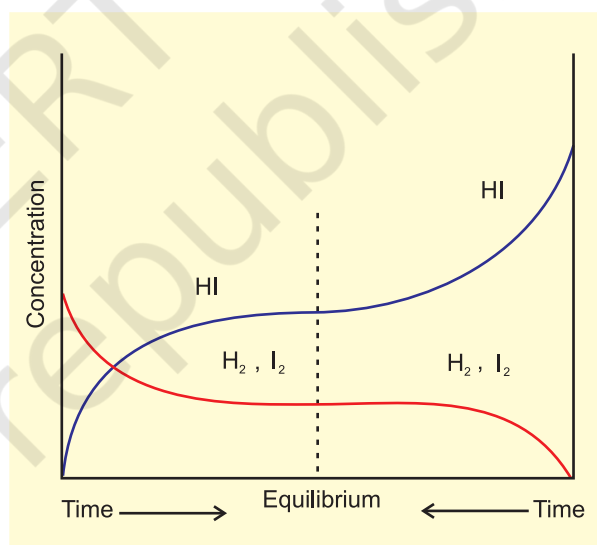

Fig. 6.5 Chemical equilibrium in the reaction $\text{H}_2(\text{g}) + \text{I}_2(\text{g}) \rightleftharpoons 2\text{HI}(\text{g})$ can be attained from either direction

6.3 LAW OF CHEMICAL EQUILIBRIUM AND EQUILIBRIUM CONSTANT

A mixture of reactants and products in the equilibrium state is called an equilibrium mixture. In this section we shall address a number of important questions about the composition of equilibrium mixtures: What is the relationship between the concentrations of reactants and products in an equilibrium mixture? How can we determine equilibrium concentrations from initial concentrations? What factors can be exploited to alter the

composition of an equilibrium mixture? The last question in particular is important when choosing conditions for synthesis of industrial chemicals such as H_2 , NH_3 , CaO etc.

To answer these questions, let us consider a general reversible reaction:

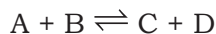

where A and B are the reactants, C and D are the products in the balanced chemical equation. On the basis of experimental studies of many reversible reactions, the Norwegian chemists Cato Maximillian Guldberg and Peter Waage proposed in 1864 that the concentrations in an equilibrium mixture are related by the following **equilibrium equation**,

$$K_c = \frac{[\text{C}][\text{D}]}{[\text{A}][\text{B}]} \quad (6.1)$$

(6.1) where K_c is the *equilibrium constant* and the expression on the right side is called the *equilibrium constant expression*.

The equilibrium equation is also known as the *law of mass action* because in the early days of chemistry, concentration was called “active mass”. In order to appreciate their work better, let us consider reaction between gaseous H_2 and I_2 carried out in a sealed vessel at 731K.

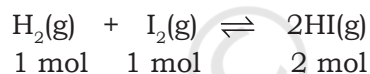

Six sets of experiments with varying initial conditions were performed, starting with only gaseous H_2 and I_2 in a sealed reaction vessel in first four experiments (1, 2, 3 and 4) and only HI in other two experiments (5 and 6). Experiment 1, 2, 3 and 4 were performed taking different concentrations of H_2 and / or I_2 , and with time it was observed that intensity of the purple colour remained constant and equilibrium was attained. Similarly, for experiments 5 and 6, the equilibrium was attained from the opposite direction.

Data obtained from all six sets of experiments are given in Table 6.2.

It is evident from the experiments 1, 2, 3 and 4 that number of moles of dihydrogen reacted = number of moles of iodine reacted = $\frac{1}{2}$ (number of moles of HI formed). Also, experiments 5 and 6 indicate that,

$$[\text{H}_2(\text{g})]_{\text{eq}} = [\text{I}_2(\text{g})]_{\text{eq}}$$

Knowing the above facts, in order to establish a relationship between concentrations of the reactants and products, several combinations can be tried. Let us consider the simple expression,

$$[\text{HI}(\text{g})]_{\text{eq}} / [\text{H}_2(\text{g})]_{\text{eq}} [\text{I}_2(\text{g})]_{\text{eq}}$$

It can be seen from Table 6.3 that if we put the equilibrium concentrations of the reactants and products, the above expression

Table 6.2 Initial and Equilibrium Concentrations of H_2 , I_2 and HI

Experiment number	Initial concentration/mol L ⁻¹			Equilibrium concentration/mol L ⁻¹		
	[H ₂ (g)]	[I ₂ (g)]	[HI (g)]	[H ₂ (g)]	[I ₂ (g)]	[HI (g)]
1	2.4×10^{-2}	1.38×10^{-2}	0	1.14×10^{-2}	0.12×10^{-2}	2.52×10^{-2}
2	2.4×10^{-2}	1.68×10^{-2}	0	0.92×10^{-2}	0.20×10^{-2}	2.96×10^{-2}
3	2.44×10^{-2}	1.98×10^{-2}	0	0.77×10^{-2}	0.31×10^{-2}	3.34×10^{-2}
4	2.46×10^{-2}	1.76×10^{-2}	0	0.92×10^{-2}	0.22×10^{-2}	3.08×10^{-2}
5	0	0	3.04×10^{-2}	0.345×10^{-2}	0.345×10^{-2}	2.35×10^{-2}
6	0	0	7.58×10^{-2}	0.86×10^{-2}	0.86×10^{-2}	5.86×10^{-2}

Table 6.3 Expression Involving the Equilibrium Concentration of Reactants



Experiments Number	$\frac{[\text{HI}(\text{g})]_{\text{eq}}}{[\text{H}_2(\text{g})]_{\text{eq}} [\text{I}_2(\text{g})]_{\text{eq}}}$	$\frac{[\text{HI}(\text{g})]_{\text{eq}}^2}{[\text{H}_2(\text{g})]_{\text{eq}} [\text{I}_2(\text{g})]_{\text{eq}}}$
1	1840	46.4
2	1610	47.6
3	1400	46.7
4	1520	46.9
5	1970	46.4
6	790	46.4

is far from constant. However, if we consider the expression,

$$\frac{[\text{HI}(\text{g})]_{\text{eq}}^2}{[\text{H}_2(\text{g})]_{\text{eq}} [\text{I}_2(\text{g})]_{\text{eq}}}$$

we find that this expression gives constant value (as shown in Table 6.3) in all the six cases. It can be seen that in this expression the power of the concentration for reactants and products are actually the stoichiometric coefficients in the equation for the chemical reaction. Thus, for the reaction $\text{H}_2(\text{g}) + \text{I}_2(\text{g}) \rightleftharpoons 2\text{HI}(\text{g})$, following equation 6.1, the equilibrium constant K_c is written as,

$$K_c = \frac{[\text{HI}(\text{g})]_{\text{eq}}^2}{[\text{H}_2(\text{g})]_{\text{eq}} [\text{I}_2(\text{g})]_{\text{eq}}} \quad (6.2)$$

Generally the subscript 'eq' (used for equilibrium) is omitted from the concentration terms. It is taken for granted that the concentrations in the expression for K_c are equilibrium values. We, therefore, write,

$$K_c = \frac{[\text{HI}(\text{g})]^2}{[\text{H}_2(\text{g})] [\text{I}_2(\text{g})]} \quad (6.3)$$

The subscript 'c' indicates that K_c is expressed in concentrations of mol L⁻¹.

At a given temperature, the product of concentrations of the reaction products raised to the respective stoichiometric coefficient in the balanced chemical equation divided by the product of concentrations of the reactants raised to their individual stoichiometric coefficients has a constant value. This is known as the Equilibrium Law or Law of Chemical Equilibrium.

The equilibrium constant for a general reaction,

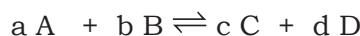

is expressed as,

$$K_c = \frac{[\text{C}]^c [\text{D}]^d}{[\text{A}]^a [\text{B}]^b} \quad (6.4)$$

where [A], [B], [C] and [D] are the equilibrium concentrations of the reactants and products.

Equilibrium constant for the reaction, $4\text{NH}_3(\text{g}) + 5\text{O}_2(\text{g}) \rightleftharpoons 4\text{NO}(\text{g}) + 6\text{H}_2\text{O}(\text{g})$ is written as

$$K_c = \frac{[\text{NO}]^4 [\text{H}_2\text{O}]^6}{[\text{NH}_3]^4 [\text{O}_2]^5}$$

Molar concentration of different species is indicated by enclosing these in square bracket and, as mentioned above, it is implied that these are equilibrium concentrations. While writing expression for equilibrium constant, symbol for phases (s, l, g) are generally ignored.

Let us write equilibrium constant for the reaction, $\text{H}_2(\text{g}) + \text{I}_2(\text{g}) \rightleftharpoons 2\text{HI}(\text{g})$ (6.5)

$$\text{as, } K_c = \frac{[\text{HI}]^2}{[\text{H}_2] [\text{I}_2]} = x \quad (6.6)$$

The equilibrium constant for the reverse reaction, $2\text{HI}(\text{g}) \rightleftharpoons \text{H}_2(\text{g}) + \text{I}_2(\text{g})$, at the same temperature is,

$$K_c = \frac{[\text{H}_2] [\text{I}_2]}{[\text{HI}]^2} = 1/x = 1/K_c \quad (6.7)$$

$$\text{Thus, } K_c = 1/K_c \quad (6.8)$$

Equilibrium constant for the reverse reaction is the inverse of the equilibrium constant for the reaction in the forward direction.

If we change the stoichiometric coefficients in a chemical equation by multiplying throughout by a factor then we must make sure that the expression for equilibrium constant also reflects that change. For example, if the reaction (6.5) is written as,

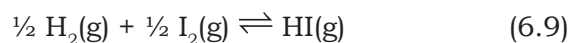

the equilibrium constant for the above reaction is given by

$$\begin{aligned} K_c'' &= \frac{[\text{HI}]}{[\text{H}_2]^{1/2} [\text{I}_2]^{1/2}} = \left\{ \frac{[\text{HI}]^2}{[\text{H}_2] [\text{I}_2]} \right\}^{1/2} \\ &= x^{1/2} = K_c^{1/2} \quad (6.10) \end{aligned}$$

On multiplying the equation (6.5) by n, we get



Therefore, equilibrium constant for the reaction is equal to K_c^n . These findings are summarised in Table 6.4. It should be noted that because the equilibrium constants K_c and K_c' have different numerical values, it is important to specify the form of the balanced chemical equation when quoting the value of an equilibrium constant.

Table 6.4 Relations between Equilibrium Constants for a General Reaction and its Multiples.

Chemical equation	Equilibrium constant
$a\text{A} + b\text{B} \rightleftharpoons c\text{C} + d\text{D}$	K_c
$c\text{C} + d\text{D} \rightleftharpoons a\text{A} + b\text{B}$	$K_c' = (1/K_c)$
$na\text{A} + nb\text{B} \rightleftharpoons nc\text{C} + nd\text{D}$	$K_c'' = (K_c^n)$

Problem 6.1

The following concentrations were obtained for the formation of NH_3 from N_2 and H_2 at equilibrium at 500K. $[\text{N}_2] = 1.5 \times 10^{-2}\text{M}$, $[\text{H}_2] = 3.0 \times 10^{-2}\text{M}$ and $[\text{NH}_3] = 1.2 \times 10^{-2}\text{M}$. Calculate equilibrium constant.

Solution

The equilibrium constant for the reaction, $\text{N}_2(\text{g}) + 3\text{H}_2(\text{g}) \rightleftharpoons 2\text{NH}_3(\text{g})$ can be written as,

$$\begin{aligned} K_c &= \frac{[\text{NH}_3(\text{g})]^2}{[\text{N}_2(\text{g})][\text{H}_2(\text{g})]^3} \\ &= \frac{(1.2 \times 10^{-2})^2}{(1.5 \times 10^{-2})(3.0 \times 10^{-2})^3} \\ &= 0.106 \times 10^4 = 1.06 \times 10^3 \end{aligned}$$

Problem 6.2

At equilibrium, the concentrations of $\text{N}_2 = 3.0 \times 10^{-3}\text{M}$, $\text{O}_2 = 4.2 \times 10^{-3}\text{M}$ and $\text{NO} = 2.8 \times 10^{-3}\text{M}$ in a sealed vessel at 800K. What will be K_c for the reaction

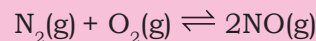

Solution

For the reaction equilibrium constant, K_c can be written as,

$$\begin{aligned} K_c &= \frac{[\text{NO}]^2}{[\text{N}_2][\text{O}_2]} \\ &= \frac{(2.8 \times 10^{-3}\text{M})^2}{(3.0 \times 10^{-3}\text{M})(4.2 \times 10^{-3}\text{M})} \\ &= 0.622 \end{aligned}$$

6.4 HOMOGENEOUS EQUILIBRIA

In a homogeneous system, all the reactants and products are in the same phase. For example, in the gaseous reaction, $\text{N}_2(\text{g}) + 3\text{H}_2(\text{g}) \rightleftharpoons 2\text{NH}_3(\text{g})$, reactants and products are in the homogeneous phase. Similarly, for the reactions,

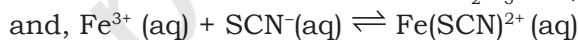
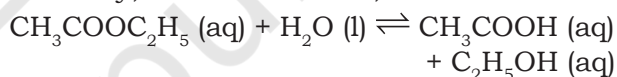

all the reactants and products are in homogeneous solution phase. We shall now consider equilibrium constant for some homogeneous reactions.

6.4.1 Equilibrium Constant in Gaseous Systems

So far we have expressed equilibrium constant of the reactions in terms of molar concentration of the reactants and products, and used symbol, K_c for it. For reactions involving gases, however, it is usually more convenient to express the equilibrium constant in terms of partial pressure.

The ideal gas equation is written as,
 $pV = nRT$

$$\Rightarrow p = \frac{n}{V}RT$$

Here, p is the pressure in Pa, n is the number of moles of the gas, V is the volume in m^3 and T is the temperature in Kelvin

Therefore,

n/V is concentration expressed in mol/m^3

If concentration c , is in mol/L or mol/dm^3 , and p is in bar then

$$p = cRT,$$

We can also write $p = [\text{gas}]RT$.

Here, $R = 0.0831 \text{ bar litre/mol K}$

At constant temperature, the pressure of the gas is proportional to its concentration i.e.,

$$p \propto [\text{gas}]$$

For reaction in equilibrium

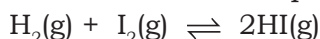

We can write either

$$K_c = \frac{[\text{HI}(\text{g})]^2}{[\text{H}_2(\text{g})][\text{I}_2(\text{g})]}$$

$$\text{or } K_c = \frac{(p_{\text{HI}})^2}{(p_{\text{H}_2})(p_{\text{I}_2})} \quad (6.12)$$

Further, since $p_{\text{HI}} = [\text{HI}(\text{g})]RT$

$$p_{\text{I}_2} = [\text{I}_2(\text{g})]RT$$

$$p_{\text{H}_2} = [\text{H}_2(\text{g})]RT$$

Therefore,

$$\begin{aligned} K_p &= \frac{(p_{\text{HI}})^2}{(p_{\text{H}_2})(p_{\text{I}_2})} = \frac{[\text{HI}(\text{g})]^2 [RT]^2}{[\text{H}_2(\text{g})]RT \cdot [\text{I}_2(\text{g})]RT} \\ &= \frac{[\text{HI}(\text{g})]^2}{[\text{H}_2(\text{g})][\text{I}_2(\text{g})]} = K_c \quad (6.13) \end{aligned}$$

In this example, $K_p = K_c$ i.e., both equilibrium constants are equal. However, this is not always the case. For example in reaction

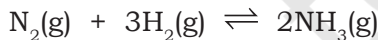

$$\begin{aligned} K_p &= \frac{(p_{\text{NH}_3})^2}{(p_{\text{N}_2})(p_{\text{H}_2})^3} \\ &= \frac{[\text{NH}_3(\text{g})]^2 [RT]^2}{[\text{N}_2(\text{g})]RT \cdot [\text{H}_2(\text{g})]^3 (RT)^3} \end{aligned}$$

$$= \frac{[\text{NH}_3(\text{g})]^2 [RT]^{-2}}{[\text{N}_2(\text{g})][\text{H}_2(\text{g})]^3} = K_c (RT)^{-2}$$

$$\text{or } K_p = K_c (RT)^{-2} \quad (6.14)$$

Similarly, for a general reaction

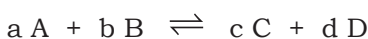

$$\begin{aligned} K_p &= \frac{(p_c^c)(p_d^d)}{(p_a^a)(p_b^b)} = \frac{[\text{C}]^c [\text{D}]^d (RT)^{(c+d)}}{[\text{A}]^a [\text{B}]^b (RT)^{(a+b)}} \\ &= \frac{[\text{C}]^c [\text{D}]^d}{[\text{A}]^a [\text{B}]^b} (RT)^{(c+d)-(a+b)} \\ &= \frac{[\text{C}]^c [\text{D}]^d}{[\text{A}]^a [\text{B}]^b} (RT)^{\Delta n} = K_c (RT)^{\Delta n} \quad (6.15) \end{aligned}$$

where $\Delta n = (\text{number of moles of gaseous products}) - (\text{number of moles of gaseous reactants})$ in the balanced chemical equation.

It is necessary that while calculating the value of K_p , pressure should be expressed in bar because standard state for pressure is 1 bar. We know from Unit 1 that:

$$1 \text{ pascal, Pa} = 1 \text{ Nm}^{-2}, \text{ and } 1 \text{ bar} = 10^5 \text{ Pa}$$

K_p values for a few selected reactions at different temperatures are given in Table 6.5

Table 6.5 Equilibrium Constants, K_p for a Few Selected Reactions

Reaction	Temperature/K	K_p
$\text{N}_2(\text{g}) + 3\text{H}_2(\text{g}) \rightleftharpoons 2\text{NH}_3$	298	6.8×10^5
	400	41
	500	3.6×10^{-2}
$2\text{SO}_2(\text{g}) + \text{O}_2(\text{g}) \rightleftharpoons 2\text{SO}_3(\text{g})$	298	4.0×10^{24}
	500	2.5×10^{10}
	700	3.0×10^4
$\text{N}_2\text{O}_4(\text{g}) \rightleftharpoons 2\text{NO}_2(\text{g})$	298	0.98
	400	47.9
	500	1700

Problem 6.3

PCl_5 , PCl_3 and Cl_2 are at equilibrium at 500 K and having concentration 1.59M PCl_3 , 1.59M Cl_2 and 1.41 M PCl_5 .

Calculate K_c for the reaction,

$$\text{PCl}_5 \rightleftharpoons \text{PCl}_3 + \text{Cl}_2$$

Solution

The equilibrium constant K_c for the above reaction can be written as,

$$K_c = \frac{[\text{PCl}_3][\text{Cl}_2]}{[\text{PCl}_5]} = \frac{(1.59)^2}{(1.41)} = 1.79$$

Problem 6.4

The value of $K_c = 4.24$ at 800K for the reaction,

$$\text{CO (g)} + \text{H}_2\text{O (g)} \rightleftharpoons \text{CO}_2 \text{ (g)} + \text{H}_2 \text{ (g)}$$

 Calculate equilibrium concentrations of CO_2 , H_2 , CO and H_2O at 800 K, if only CO and H_2O are present initially at concentrations of 0.10M each.

Solution

For the reaction,

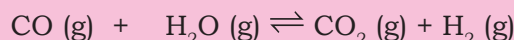

Initial concentration:

$$0.1\text{M} \quad 0.1\text{M} \quad 0 \quad 0$$

Let x mole per litre of each of the product be formed.

At equilibrium:

$$(0.1-x)\text{M} \quad (0.1-x)\text{M} \quad x\text{M} \quad x\text{M}$$

where x is the amount of CO_2 and H_2 at equilibrium.

Hence, equilibrium constant can be written as,

$$K_c = x^2 / (0.1-x)^2 = 4.24$$

$$x^2 = 4.24(0.1 - x)^2$$

$$x^2 = 0.0424 + 4.24x^2 - 0.848x$$

$$3.24x^2 - 0.848x + 0.0424 = 0$$

$$a = 3.24, b = -0.848, c = 0.0424$$

(for quadratic equation $ax^2 + bx + c = 0$,

$$x = \frac{-b \pm \sqrt{b^2 - 4ac}}{2a}$$

$$x = \frac{0.848 \pm \sqrt{(0.848)^2 - 4(3.24)(0.0424)}}{2(3.24)}$$

$$x = (0.848 \pm 0.4118) / 6.48$$

$$x_1 = (0.848 - 0.4118) / 6.48 = 0.067$$

$$x_2 = (0.848 + 0.4118) / 6.48 = 0.194$$

the value 0.194 should be neglected because it will give concentration of the reactant which is more than initial concentration.

Hence the equilibrium concentrations are,

$$[\text{CO}_2] = [\text{H}_2] = x = 0.067 \text{ M}$$

$$[\text{CO}] = [\text{H}_2\text{O}] = 0.1 - 0.067 = 0.033 \text{ M}$$

Problem 6.5

For the equilibrium,

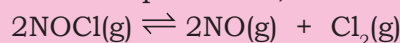

the value of the equilibrium constant, K_c is 3.75×10^{-6} at 1069 K. Calculate the K_p for the reaction at this temperature?

Solution

We know that,

$$K_p = K_c(RT)^{\Delta n}$$

For the above reaction,

$$\Delta n = (2+1) - 2 = 1$$

$$K_p = 3.75 \times 10^{-6} (0.0831 \times 1069)$$

$$K_p = 0.033$$

6.5 HETEROGENEOUS EQUILIBRIA

Equilibrium in a system having more than one phase is called heterogeneous equilibrium. The equilibrium between water vapour and liquid water in a closed container is an example of heterogeneous equilibrium.

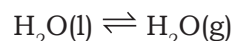

In this example, there is a gas phase and a liquid phase. In the same way, equilibrium between a solid and its saturated solution,

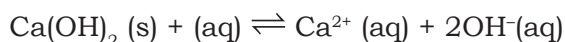

is a heterogeneous equilibrium.

Heterogeneous equilibria often involve pure solids or liquids. We can simplify equilibrium expressions for the heterogeneous equilibria involving a pure liquid or a pure solid, as the molar concentration of a pure solid or liquid is constant (i.e., independent of the amount present). In other words if a substance 'X' is involved, then $[\text{X(s)}]$ and $[\text{X(l)}]$ are constant, whatever the amount of 'X' is taken. Contrary to this, $[\text{X(g)}]$ and $[\text{X(aq)}]$ will

vary as the amount of X in a given volume varies. Let us take thermal dissociation of calcium carbonate which is an interesting and important example of heterogeneous chemical equilibrium.

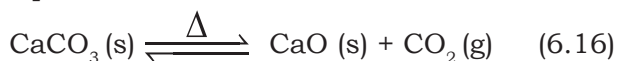

On the basis of the stoichiometric equation, we can write,

$$K_c = \frac{[\text{CaO}(\text{s})][\text{CO}_2(\text{g})]}{[\text{CaCO}_3(\text{s})]}$$

Since $[\text{CaCO}_3(\text{s})]$ and $[\text{CaO}(\text{s})]$ are both constant, therefore modified equilibrium constant for the thermal decomposition of calcium carbonate will be

$$K'_c = [\text{CO}_2(\text{g})] \quad (6.17)$$

$$\text{or } K_p = p_{\text{CO}_2} \quad (6.18)$$

Units of Equilibrium Constant

The value of equilibrium constant K_c can be calculated by substituting the concentration terms in mol/L and for K_p partial pressure is substituted in Pa, kPa, bar or atm. This results in units of equilibrium constant based on molarity or pressure, unless the exponents of both the numerator and denominator are same.

For the reactions,

$\text{H}_2(\text{g}) + \text{I}_2(\text{g}) \rightleftharpoons 2\text{HI}$, K_c and K_p have no unit.

$\text{N}_2\text{O}_4(\text{g}) \rightleftharpoons 2\text{NO}_2(\text{g})$, K_c has unit mol/L and K_p has unit bar

Equilibrium constants can also be expressed as dimensionless quantities if the standard state of reactants and products are specified. For a pure gas, the standard state is 1 bar. Therefore a pressure of 4 bar in standard state can be expressed as 4 bar/1 bar = 4, which is a dimensionless number. Standard state (c_0) for a solute is 1 molar solution and all concentrations can be measured with respect to it. The numerical value of equilibrium constant depends on the standard state chosen. Thus, in this system both K_p and K_c are dimensionless quantities but have different numerical values due to different standard states.

This shows that at a particular temperature, there is a constant concentration or pressure of CO_2 in equilibrium with $\text{CaO}(\text{s})$ and $\text{CaCO}_3(\text{s})$. Experimentally it has been found that at 1100 K, the pressure of CO_2 in equilibrium with $\text{CaCO}_3(\text{s})$ and $\text{CaO}(\text{s})$, is 2.0×10^5 Pa. Therefore, equilibrium constant at 1100K for the above reaction is:

$$K_p = P_{\text{CO}_2} = 2 \times 10^5 \text{ Pa} / 10^5 \text{ Pa} = 2.00$$

Similarly, in the equilibrium between nickel, carbon monoxide and nickel carbonyl (used in the purification of nickel),

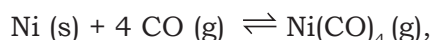

the equilibrium constant is written as

$$K_c = \frac{[\text{Ni}(\text{CO})_4]}{[\text{CO}]^4}$$

It must be remembered that for the existence of heterogeneous equilibrium pure solids or liquids must also be present (however small the amount may be) at equilibrium, but their concentrations or partial pressures do not appear in the expression of the equilibrium constant. In the reaction,

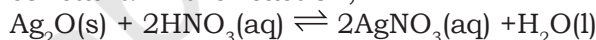

$$K_c = \frac{[\text{AgNO}_3]^2}{[\text{HNO}_3]^2}$$

Problem 6.6

The value of K_p for the reaction, $\text{CO}_2(\text{g}) + \text{C}(\text{s}) \rightleftharpoons 2\text{CO}(\text{g})$ is 3.0 at 1000 K. If initially $P_{\text{CO}_2} = 0.48$ bar and $P_{\text{CO}} = 0$ bar and pure graphite is present, calculate the equilibrium partial pressures of CO and CO_2 .

Solution

For the reaction,

let 'x' be the decrease in pressure of CO_2 , then

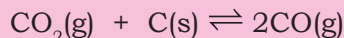

Initial

pressure: 0.48 bar

0

At equilibrium:

$$(0.48 - x)\text{bar} \quad 2x \text{ bar}$$

$$K_p = \frac{P_{CO}^2}{P_{CO_2}}$$

$$K_p = (2x)^2 / (0.48 - x) = 3$$

$$4x^2 = 3(0.48 - x)$$

$$4x^2 = 1.44 - x$$

$$4x^2 + 3x - 1.44 = 0$$

$$a = 4, b = 3, c = -1.44$$

$$x = \frac{(-b \pm \sqrt{b^2 - 4ac})}{2a}$$

$$= [-3 \pm \sqrt{(3)^2 - 4(4)(-1.44)}] / 2 \times 4$$

$$= (-3 \pm 5.66) / 8$$

$$= (-3 + 5.66) / 8 \text{ (as value of } x \text{ cannot be negative hence we neglect that value)}$$

$$x = 2.66 / 8 = 0.33$$

The equilibrium partial pressures are,

$$p_{CO_2} = 2x = 2 \times 0.33 = 0.66 \text{ bar}$$

$$p_{CO} = 0.48 - x = 0.48 - 0.33 = 0.15 \text{ bar}$$

6.6 APPLICATIONS OF EQUILIBRIUM CONSTANTS

Before considering the applications of equilibrium constants, let us summarise the important features of equilibrium constants as follows:

1. Expression for equilibrium constant is applicable only when concentrations of the reactants and products have attained constant value at equilibrium state.
2. The value of equilibrium constant is independent of initial concentrations of the reactants and products.
3. Equilibrium constant is temperature dependent having one unique value for a particular reaction represented by a balanced equation at a given temperature.
4. The equilibrium constant for the reverse reaction is equal to the inverse of the equilibrium constant for the forward reaction.

5. The equilibrium constant K for a reaction is related to the equilibrium constant of the corresponding reaction, whose equation is obtained by multiplying or dividing the equation for the original reaction by a small integer.

Let us consider applications of equilibrium constant to:

- predict the extent of a reaction on the basis of its magnitude,
- predict the direction of the reaction, and
- calculate equilibrium concentrations.

6.6.1 Predicting the Extent of a Reaction

The numerical value of the equilibrium constant for a reaction indicates the extent of the reaction. But it is important to note that an equilibrium constant does not give any information about the *rate* at which the equilibrium is reached. The magnitude of K_c or K_p is directly proportional to the concentrations of products (as these appear in the numerator of equilibrium constant expression) and inversely proportional to the concentrations of the reactants (these appear in the denominator). This implies that a high value of K is suggestive of a high concentration of products and vice-versa.

We can make the following generalisations concerning the composition of equilibrium mixtures:

- If $K_c > 10^3$, products predominate over reactants, i.e., if K_c is very large, the reaction proceeds nearly to completion. Consider the following examples:
 - (a) The reaction of H_2 with O_2 at 500 K has a very large equilibrium constant, $K_c = 2.4 \times 10^{47}$.
 - (b) $H_2(g) + Cl_2(g) \rightleftharpoons 2HCl(g)$ at 300K has $K_c = 4.0 \times 10^{31}$.
 - (c) $H_2(g) + Br_2(g) \rightleftharpoons 2HBr(g)$ at 300 K, $K_c = 5.4 \times 10^{18}$
- If $K_c < 10^{-3}$, reactants predominate over products, i.e., if K_c is very small, the reaction proceeds rarely. Consider the following examples:

- (a) The decomposition of H_2O into H_2 and O_2 at 500 K has a very small equilibrium constant, $K_c = 4.1 \times 10^{-48}$
- (b) $\text{N}_2(\text{g}) + \text{O}_2(\text{g}) \rightleftharpoons 2\text{NO}(\text{g})$, at 298 K has $K_c = 4.8 \times 10^{-31}$.
- If K_c is in the range of 10^{-3} to 10^3 , appreciable concentrations of both reactants and products are present. Consider the following examples:
- (a) For reaction of H_2 with I_2 to give HI, $K_c = 57.0$ at 700K.
- (b) Also, gas phase decomposition of N_2O_4 to NO_2 is another reaction with a value of $K_c = 4.64 \times 10^{-3}$ at 25°C which is neither too small nor too large. Hence, equilibrium mixtures contain appreciable concentrations of both N_2O_4 and NO_2 . These generalisations are illustrated in Fig. 6.6

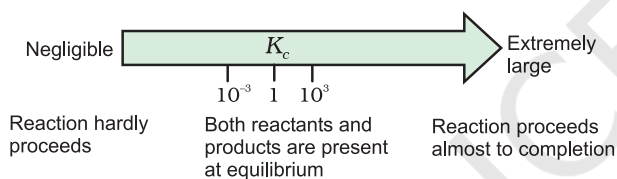

Fig. 6.6 Dependence of extent of reaction on K_c

6.6.2 Predicting the Direction of the Reaction

The equilibrium constant helps in predicting the direction in which a given reaction will proceed at any stage. For this purpose, we calculate the **reaction quotient Q** . The reaction quotient, Q (Q_c with molar concentrations and Q_p with partial pressures) is defined in the same way as the equilibrium constant K_c except that the concentrations in Q_c are not necessarily equilibrium values. For a general reaction:



$$Q_c = \frac{[\text{C}]^c[\text{D}]^d}{[\text{A}]^a[\text{B}]^b} \quad (6.20)$$

Then,

If $Q_c > K_c$, the reaction will proceed in the direction of reactants (reverse reaction).

If $Q_c < K_c$, the reaction will proceed in the direction of the products (forward reaction).

If $Q_c = K_c$, the reaction mixture is already at equilibrium.

Consider the gaseous reaction of H_2 with I_2 ,

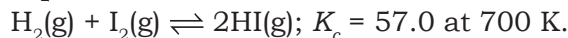

Suppose we have molar concentrations $[\text{H}_2]_t = 0.10\text{M}$, $[\text{I}_2]_t = 0.20\text{M}$ and $[\text{HI}]_t = 0.40\text{M}$. (the subscript t on the concentration symbols means that the concentrations were measured at some arbitrary time t, not necessarily at equilibrium).

Thus, the reaction quotient, Q_c at this stage of the reaction is given by,

$$Q_c = \frac{[\text{HI}]_t^2}{[\text{H}_2]_t [\text{I}_2]_t} = \frac{(0.40)^2}{(0.10)(0.20)} = 8.0$$

Now, in this case, Q_c (8.0) does not equal K_c (57.0), so the mixture of $\text{H}_2(\text{g})$, $\text{I}_2(\text{g})$ and $\text{HI}(\text{g})$ is not at equilibrium; that is, more $\text{H}_2(\text{g})$ and $\text{I}_2(\text{g})$ will react to form more $\text{HI}(\text{g})$ and their concentrations will decrease till $Q_c = K_c$.

The reaction quotient, Q_c is useful in predicting the direction of reaction by comparing the values of Q_c and K_c .

Thus, we can make the following generalisations concerning the direction of the reaction (Fig. 6.7) :

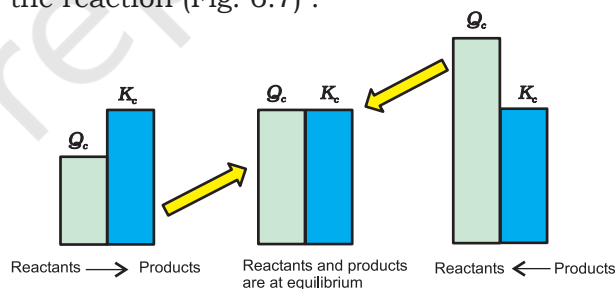

Fig. 6.7 Predicting the direction of the reaction

- If $Q_c < K_c$, net reaction goes from left to right
- If $Q_c > K_c$, net reaction goes from right to left.
- If $Q_c = K_c$, no net reaction occurs.

Problem 6.7

The value of K_c for the reaction $2\text{A} \rightleftharpoons \text{B} + \text{C}$ is 2×10^{-3} . At a given time, the composition of reaction mixture is $[\text{A}] = [\text{B}] = [\text{C}] = 3 \times 10^{-4}\text{M}$. In which direction the reaction will proceed?

Solution

For the reaction the reaction quotient Q_c is given by,

$$Q_c = \frac{[B][C]}{[A]^2}$$

as $[A] = [B] = [C] = 3 \times 10^{-4} \text{M}$

$$Q_c = \frac{(3 \times 10^{-4})(3 \times 10^{-4})}{(3 \times 10^{-4})^2} = 1$$

as $Q_c > K_c$ so the reaction will proceed in the reverse direction.

6.6.3 Calculating Equilibrium Concentrations

In case of a problem in which we know the initial concentrations but do not know any of the equilibrium concentrations, the following three steps shall be followed:

Step 1. Write the balanced equation for the reaction.

Step 2. Under the balanced equation, make a table that lists for each substance involved in the reaction:

- the initial concentration,
- the change in concentration on going to equilibrium, and
- the equilibrium concentration.

In constructing the table, define x as the concentration (mol/L) of one of the substances that reacts on going to equilibrium, then use the stoichiometry of the reaction to determine the concentrations of the other substances in terms of x .

Step 3. Substitute the equilibrium concentrations into the equilibrium equation for the reaction and solve for x . If you are to solve a quadratic equation choose the mathematical solution that makes chemical sense.

Step 4. Calculate the equilibrium concentrations from the calculated value of x .

Step 5. Check your results by substituting them into the equilibrium equation.

Problem 6.8

13.8g of N_2O_4 was placed in a 1L reaction vessel at 400K and allowed to attain equilibrium



The total pressure at equilibrium was found to be 9.15 bar. Calculate K_c , K_p and partial pressure at equilibrium.

Solution

We know $pV = nRT$

Total volume (V) = 1 L

Molecular mass of $\text{N}_2\text{O}_4 = 92 \text{ g}$

Number of moles = $13.8\text{g}/92 \text{ g} = 0.15$

of the gas (n)

Gas constant (R) = $0.083 \text{ bar L mol}^{-1}\text{K}^{-1}$

Temperature (T) = 400 K

$$pV = nRT$$

$$p \times 1\text{L} = 0.15 \text{ mol} \times 0.083 \text{ bar L mol}^{-1}\text{K}^{-1} \times 400 \text{ K}$$

$$p = 4.98 \text{ bar}$$



Initial pressure: 4.98 bar 0

At equilibrium: $(4.98 - x)$ bar $2x$ bar

Hence,

$$p_{\text{total}} \text{ at equilibrium} = p_{\text{N}_2\text{O}_4} + p_{\text{NO}_2}$$

$$9.15 = (4.98 - x) + 2x$$

$$9.15 = 4.98 + x$$

$$x = 9.15 - 4.98 = 4.17 \text{ bar}$$

Partial pressures at equilibrium are,

$$p_{\text{N}_2\text{O}_4} = 4.98 - 4.17 = 0.81 \text{ bar}$$

$$p_{\text{NO}_2} = 2x = 2 \times 4.17 = 8.34 \text{ bar}$$

$$K_p = \frac{(p_{\text{NO}_2})^2}{p_{\text{N}_2\text{O}_4}} = \frac{(8.34)^2}{0.81} = 85.87$$

$$K_p = K_c(RT)^{\Delta n}$$

$$85.87 = K_c(0.083 \times 400)^1$$

$$K_c = 2.586 = 2.6$$

Problem 6.9

3.00 mol of PCl_5 kept in 1L closed reaction vessel was allowed to attain equilibrium at 380K. Calculate composition of the mixture at equilibrium. $K_c = 1.80$

Solution

Initial

concentration: 3.0 0 0

Let x mol per litre of PCl_5 be dissociated,
At equilibrium:

$$\begin{array}{ccc}
 & (3-x) & x & x \\
 K_c = [\text{PCl}_3][\text{Cl}_2]/[\text{PCl}_5] \\
 1.8 = x^2 / (3-x) \\
 x^2 + 1.8x - 5.4 = 0 \\
 x = [-1.8 \pm \sqrt{(1.8)^2 - 4(-5.4)}] / 2 \\
 x = [-1.8 \pm \sqrt{3.24 + 21.6}] / 2 \\
 x = [-1.8 \pm 4.98] / 2 \\
 x = [-1.8 + 4.98] / 2 = 1.59 \\
 [\text{PCl}_5] = 3.0 - x = 3 - 1.59 = 1.41 \text{ M} \\
 [\text{PCl}_3] = [\text{Cl}_2] = x = 1.59 \text{ M}
 \end{array}$$

6.7 RELATIONSHIP BETWEEN EQUILIBRIUM CONSTANT K_c , REACTION QUOTIENT Q AND GIBBS ENERGY G

The value of K_c for a reaction does not depend on the rate of the reaction. However, as you have studied in Unit 5, it is directly related to the thermodynamics of the reaction and in particular, to the change in Gibbs energy, ΔG . If,

- ΔG is negative, then the reaction is spontaneous and proceeds in the forward direction.
- ΔG is positive, then reaction is considered non-spontaneous. Instead, as reverse reaction would have a negative ΔG , the products of the forward reaction shall be converted to the reactants.
- ΔG is 0, reaction has achieved equilibrium; at this point, there is no longer any free energy left to drive the reaction.

A mathematical expression of this thermodynamic view of equilibrium can be described by the following equation:

$$\Delta G = \Delta G^\ominus + RT \ln Q \quad (6.21)$$

where, G^\ominus is standard Gibbs energy.

At equilibrium, when $\Delta G = 0$ and $Q = K_c$, the equation (6.21) becomes,

$$\begin{aligned}
 \Delta G &= \Delta G^\ominus + RT \ln K = 0 \\
 \Delta G^\ominus &= -RT \ln K \\
 \ln K &= -\Delta G^\ominus / RT
 \end{aligned} \quad (6.22)$$

Taking antilog of both sides, we get,

$$K = e^{-\Delta G^\ominus / RT} \quad (6.23)$$

Hence, using the equation (6.23), the reaction spontaneity can be interpreted in terms of the value of ΔG^\ominus .

- If $\Delta G^\ominus < 0$, then $-\Delta G^\ominus / RT$ is positive, and $e^{-\Delta G^\ominus / RT} > 1$, making $K > 1$, which implies a spontaneous reaction or the reaction which proceeds in the forward direction to such an extent that the products are present predominantly.
- If $\Delta G^\ominus > 0$, then $-\Delta G^\ominus / RT$ is negative, and $e^{-\Delta G^\ominus / RT} < 1$, that is, $K < 1$, which implies a non-spontaneous reaction or a reaction which proceeds in the forward direction to such a small degree that only a very minute quantity of product is formed.

Problem 6.10

The value of ΔG^\ominus for the phosphorylation of glucose in glycolysis is 13.8 kJ/mol. Find the value of K_c at 298 K.

Solution

$$\Delta G^\ominus = 13.8 \text{ kJ/mol} = 13.8 \times 10^3 \text{ J/mol}$$

$$\text{Also, } \Delta G^\ominus = -RT \ln K_c$$

$$\text{Hence, } \ln K_c = -13.8 \times 10^3 \text{ J/mol} / (8.314 \text{ J mol}^{-1} \text{K}^{-1} \times 298 \text{ K})$$

$$\ln K_c = -5.569$$

$$K_c = e^{-5.569}$$

$$K_c = 3.81 \times 10^{-3}$$

Problem 6.11

Hydrolysis of sucrose gives,

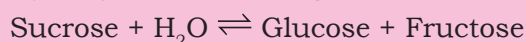

Equilibrium constant K_c for the reaction is 2×10^{13} at 300K. Calculate ΔG^\ominus at 300K.

Solution

$$\Delta G^\ominus = -RT \ln K_c$$

$$\Delta G^\ominus = -8.314 \text{ J mol}^{-1} \text{K}^{-1} \times 300 \text{ K} \times \ln(2 \times 10^{13})$$

$$\Delta G^\ominus = -7.64 \times 10^4 \text{ J mol}^{-1}$$

6.8 FACTORS AFFECTING EQUILIBRIA

One of the principal goals of chemical synthesis is to maximise the conversion of the

reactants to products while minimising the expenditure of energy. This implies maximum yield of products at mild temperature and pressure conditions. If it does not happen, then the experimental conditions need to be adjusted. For example, in the Haber process for the synthesis of ammonia from N_2 and H_2 , the choice of experimental conditions is of real economic importance. Annual world production of ammonia is about hundred million tones, primarily for use as fertilisers.

Equilibrium constant, K_c is independent of initial concentrations. But if a system at equilibrium is subjected to a change in the concentration of one or more of the reacting substances, then the system is no longer at equilibrium; and net reaction takes place in some direction until the system returns to equilibrium once again. Similarly, a change in temperature or pressure of the system may also alter the equilibrium. In order to decide what course the reaction adopts and *make a qualitative prediction* about the effect of a change in conditions on equilibrium we use **Le Chatelier's principle**. It states that **a change in any of the factors that determine the equilibrium conditions of a system will cause the system to change in such a manner so as to reduce or to counteract the effect of the change.** This is applicable to all physical and chemical equilibria.

We shall now be discussing factors which can influence the equilibrium.

6.8.1 Effect of Concentration Change

In general, when equilibrium is disturbed by the addition/removal of any reactant/products, Le Chatelier's principle predicts that:

- The concentration stress of an *added* reactant/product is relieved by net reaction in the direction that consumes the added substance.
 - The concentration stress of a *removed* reactant/product is relieved by net reaction in the direction that *replenishes* the removed substance.
- or in other words,

“When the concentration of any of the reactants or products in a reaction at equilibrium is changed, the composition of the equilibrium mixture changes so as to minimize the effect of concentration changes”.

Let us take the reaction,

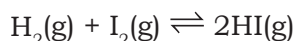

If H_2 is added to the reaction mixture at equilibrium, then the equilibrium of the reaction is disturbed. In order to restore it, the reaction proceeds in a direction wherein H_2 is consumed, i.e., more of H_2 and I_2 react to form HI and finally the equilibrium shifts in right (forward) direction (Fig.6.8). This is in accordance with the Le Chatelier's principle which implies that in case of addition of a reactant/product, a new equilibrium will be set up in which the concentration of the reactant/product should be less than what it was after the addition but more than what it was in the original mixture.

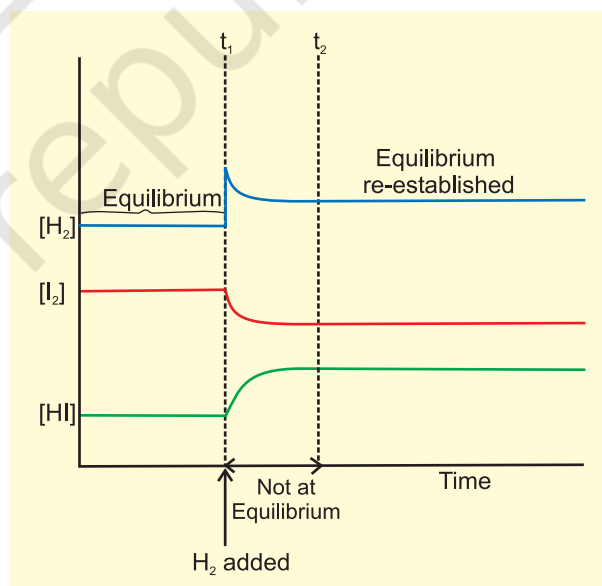

Fig. 6.8 Effect of addition of H_2 on change of concentration for the reactants and products in the reaction, $H_2(g) + I_2(g) \rightleftharpoons 2HI(g)$

The same point can be explained in terms of the reaction quotient, Q_c ,

$$Q_c = \frac{[HI]^2}{[H_2][I_2]}$$

Addition of hydrogen at equilibrium results in value of Q_c being less than K_c . Thus, in order to attain equilibrium again reaction moves in the forward direction. Similarly, we can say that removal of a product also boosts the forward reaction and increases the concentration of the products and this has great commercial application in cases of reactions, where the product is a gas or a volatile substance. In case of manufacture of ammonia, ammonia is liquified and removed from the reaction mixture so that reaction keeps moving in forward direction. Similarly, in the large scale production of CaO (used as important building material) from CaCO_3 , constant removal of CO_2 from the kiln drives the reaction to completion. It should be remembered that continuous removal of a product maintains Q_c at a value less than K_c and reaction continues to move in the forward direction.

Effect of Concentration – An experiment

This can be demonstrated by the following reaction:

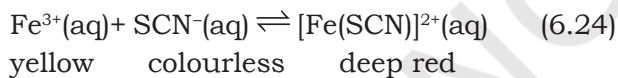

$$K_c = \frac{[\text{Fe}(\text{SCN})^{2+}(\text{aq})]}{[\text{Fe}^{3+}(\text{aq})][\text{SCN}^{-}(\text{aq})]} \quad (6.25)$$

A reddish colour appears on adding two drops of 0.002 M potassium thiocyanate solution to 1 mL of 0.2 M iron(III) nitrate solution due to the formation of $[\text{Fe}(\text{SCN})]^{2+}$. The intensity of the red colour becomes constant on attaining equilibrium. This equilibrium can be shifted in either forward or reverse directions depending on our choice of adding a reactant or a product. The equilibrium can be shifted in the opposite direction by adding reagents that remove Fe^{3+} or SCN^{-} ions. For example, oxalic acid ($\text{H}_2\text{C}_2\text{O}_4$), reacts with Fe^{3+} ions to form the stable complex ion $[\text{Fe}(\text{C}_2\text{O}_4)_3]^{3-}$, thus decreasing the concentration of free $\text{Fe}^{3+}(\text{aq})$. In accordance with the Le Chatelier's principle, the concentration stress of removed Fe^{3+} is relieved by dissociation of $[\text{Fe}(\text{SCN})]^{2+}$ to replenish the Fe^{3+} ions. Because the

concentration of $[\text{Fe}(\text{SCN})]^{2+}$ decreases, the intensity of red colour decreases.

Addition of aq. HgCl_2 also decreases red colour because Hg^{2+} reacts with SCN^{-} ions to form stable complex ion $[\text{Hg}(\text{SCN})_4]^{2-}$. Removal of free $\text{SCN}^{-}(\text{aq})$ shifts the equilibrium in equation (6.24) from right to left to replenish SCN^{-} ions. Addition of potassium thiocyanate on the other hand increases the colour intensity of the solution as it shifts the equilibrium to right.

6.8.2 Effect of Pressure Change

A pressure change obtained by changing the volume can affect the yield of products in case of a gaseous reaction where the total number of moles of gaseous reactants and total number of moles of gaseous products are different. In applying Le Chatelier's principle to a heterogeneous equilibrium the effect of pressure changes on solids and liquids can be ignored because the volume (and concentration) of a solution/liquid is nearly independent of pressure.

Consider the reaction,

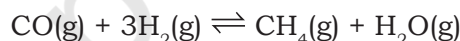

Here, 4 mol of gaseous reactants ($\text{CO} + 3\text{H}_2$) become 2 mol of gaseous products ($\text{CH}_4 + \text{H}_2\text{O}$). Suppose equilibrium mixture (for above reaction) kept in a cylinder fitted with a piston at constant temperature is compressed to one half of its original volume. Then, total pressure will be doubled (according to $pV = \text{constant}$). The partial pressure and therefore, concentration of reactants and products have changed and the mixture is no longer at equilibrium. The direction in which the reaction goes to re-establish equilibrium can be predicted by applying the Le Chatelier's principle. Since pressure has doubled, the equilibrium now shifts in the forward direction, a direction in which the number of moles of the gas or pressure decreases (we know pressure is proportional to moles of the gas). This can also be understood by using reaction quotient, Q_c . Let $[\text{CO}]$, $[\text{H}_2]$, $[\text{CH}_4]$ and $[\text{H}_2\text{O}]$ be the molar concentrations at equilibrium for methanation reaction. When volume of the reaction mixture is halved, the

partial pressure and the concentration are doubled. We obtain the reaction quotient by replacing each equilibrium concentration by double its value.

$$Q_c = \frac{[\text{CH}_4(\text{g})][\text{H}_2\text{O}(\text{g})]}{[\text{CO}(\text{g})][\text{H}_2(\text{g})]^3}$$

As $Q_c < K_c$, the reaction proceeds in the forward direction.

In reaction $\text{C}(\text{s}) + \text{CO}_2(\text{g}) \rightleftharpoons 2\text{CO}(\text{g})$, when pressure is increased, the reaction goes in the reverse direction because the number of moles of gas increases in the forward direction.

6.8.3 Effect of Inert Gas Addition

If the volume is kept constant and an inert gas such as argon is added which does not take part in the reaction, the equilibrium remains undisturbed. It is because the addition of an inert gas at constant volume does not change the partial pressures or the molar concentrations of the substance involved in the reaction. The reaction quotient changes only if the added gas is a reactant or product involved in the reaction.

6.8.4 Effect of Temperature Change

Whenever an equilibrium is disturbed by a change in the concentration, pressure or volume, the composition of the equilibrium mixture changes because the reaction quotient, Q_c no longer equals the equilibrium constant, K_c . However, when a change in temperature occurs, the value of equilibrium constant, K_c is changed.

In general, the temperature dependence of the equilibrium constant depends on the sign of ΔH for the reaction.

- The equilibrium constant for an exothermic reaction (negative ΔH) decreases as the temperature increases.
- The equilibrium constant for an endothermic reaction (positive ΔH) increases as the temperature increases.

Temperature changes affect the equilibrium constant and rates of reactions.

Production of ammonia according to the reaction,

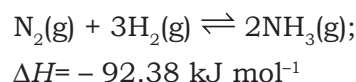

is an exothermic process. According to Le Chatelier's principle, raising the temperature shifts the equilibrium to left and decreases the equilibrium concentration of ammonia. In other words, low temperature is favourable for high yield of ammonia, but practically very low temperatures slow down the reaction and thus a catalyst is used.

Effect of Temperature – An experiment

Effect of temperature on equilibrium can be demonstrated by taking NO_2 gas (brown in colour) which dimerises into N_2O_4 gas (colourless).



NO_2 gas prepared by addition of Cu turnings to conc. HNO_3 is collected in two 5 mL test tubes (ensuring same intensity of colour of gas in each tube) and stopper sealed with araldite. Three 250 mL beakers 1, 2 and 3 containing freezing mixture, water at room temperature and hot water (363K), respectively, are taken (Fig. 6.9). Both the test tubes are placed in beaker 2 for 8-10 minutes. After this one is placed in beaker 1 and the other in beaker 3. The effect of temperature on direction of reaction is depicted very well in this experiment. At low temperatures in beaker 1, the forward reaction of formation of N_2O_4 is preferred, as reaction is exothermic, and thus, intensity of brown colour due to NO_2 decreases. While in beaker 3, high temperature favours the reverse reaction of

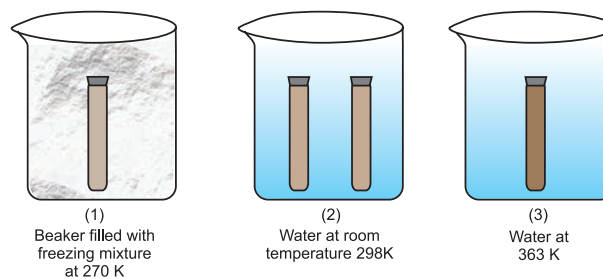
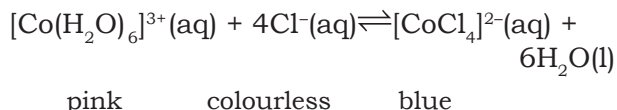

Fig. 6.9 Effect of temperature on equilibrium for the reaction, $2\text{NO}_2(\text{g}) \rightleftharpoons \text{N}_2\text{O}_4(\text{g})$

formation of NO_2 and thus, the brown colour intensifies.

Effect of temperature can also be seen in an endothermic reaction,



At room temperature, the equilibrium mixture is blue due to $[\text{CoCl}_4]^{2-}$. When cooled in a freezing mixture, the colour of the mixture turns pink due to $[\text{Co}(\text{H}_2\text{O})_6]^{3+}$.

6.8.5 Effect of a Catalyst

A catalyst increases the rate of the chemical reaction by making available a new low energy pathway for the conversion of reactants to products. It increases the rate of forward and reverse reactions that pass through the same transition state and does not affect equilibrium. Catalyst lowers the activation energy for the forward and reverse reactions by exactly the same amount. Catalyst does not affect the equilibrium composition of a reaction mixture. It does not appear in the balanced chemical equation or in the equilibrium constant expression.

Let us consider the formation of NH_3 from dinitrogen and dihydrogen which is highly exothermic reaction and proceeds with decrease in total number of moles formed as compared to the reactants. Equilibrium constant decreases with increase in temperature. At low temperature rate decreases and it takes long time to reach at equilibrium, whereas high temperatures give satisfactory rates but poor yields.

German chemist, Fritz Haber discovered that a catalyst consisting of iron catalyse the reaction to occur at a satisfactory rate at temperatures, where the equilibrium concentration of NH_3 is reasonably favourable. Since the number of moles formed in the reaction is less than those of reactants, the yield of NH_3 can be improved by increasing the pressure.

Optimum conditions of temperature and pressure for the synthesis of NH_3 using catalyst are around 500°C and 200 atm.

Similarly, in manufacture of sulphuric acid by *contact process*,



though the value of K is suggestive of reaction going to completion, but practically the oxidation of SO_2 to SO_3 is very slow. Thus, platinum or divanadium penta-oxide (V_2O_5) is used as catalyst to increase the rate of the reaction.

Note: If a reaction has an exceedingly small K , a catalyst would be of little help.

6.9 IONIC EQUILIBRIUM IN SOLUTION

Under the effect of change of concentration on the direction of equilibrium, you have incidently come across with the following equilibrium which involves ions:

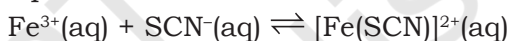

There are numerous equilibria that involve ions only. In the following sections we will study the equilibria involving ions. It is well known that the aqueous solution of sugar does not conduct electricity. However, when common salt (sodium chloride) is added to water it conducts electricity. Also, the conductance of electricity increases with an increase in concentration of common salt. Michael Faraday classified the substances into two categories based on their ability to conduct electricity. One category of substances conduct electricity in their aqueous solutions and are called *electrolytes* while the other do not and are thus, referred to as *non-electrolytes*. Faraday further classified electrolytes into *strong* and *weak* electrolytes. Strong electrolytes on dissolution in water are ionized almost completely, while the weak electrolytes are only partially dissociated. For example, an aqueous solution of sodium chloride is comprised entirely of sodium ions and chloride ions, while that of acetic acid mainly contains unionized acetic acid molecules and only some acetate ions and hydronium ions. This is because there is almost 100% ionization in case of sodium chloride as compared to less than 5% ionization of acetic acid which is a weak electrolyte. It should be noted

that in weak electrolytes, equilibrium is established between ions and the unionized molecules. This type of equilibrium involving ions in aqueous solution is called **ionic equilibrium**. Acids, bases and salts come under the category of electrolytes and may act as either strong or weak electrolytes.

6.10 ACIDS, BASES AND SALTS

Acids, bases and salts find widespread occurrence in nature. Hydrochloric acid present in the gastric juice is secreted by the lining of our stomach in a significant amount of 1.2-1.5 L/day and is essential for digestive processes. Acetic acid is known to be the main constituent of vinegar. Lemon and orange juices contain citric and ascorbic acids, and tartaric acid is found in tamarind paste. As most of the acids taste sour, the word “acid” has been derived from a latin word “*acidus*” meaning sour. Acids are known to turn blue litmus paper into red and liberate dihydrogen on reacting with some metals. Similarly, bases are known to turn red litmus paper blue, taste bitter and feel soapy. A common example of a base is washing soda used for washing purposes. When acids and bases are mixed in the right proportion they react with each other to give *salts*. Some commonly known examples of salts are sodium chloride, barium sulphate, sodium nitrate. Sodium chloride (common salt) is an important component of our diet and is formed by reaction between hydrochloric acid and sodium hydroxide. It

exists in solid state as a cluster of positively charged sodium ions and negatively charged chloride ions which are held together due to electrostatic interactions between oppositely charged species (Fig.6.10). The electrostatic forces between two charges are inversely proportional to dielectric constant of the medium. Water, a universal solvent, possesses a very high dielectric constant of 80. Thus, when sodium chloride is dissolved in water, the electrostatic interactions are reduced by a factor of 80 and this facilitates the ions to move freely in the solution. Also, they are well-separated due to hydration with water molecules.

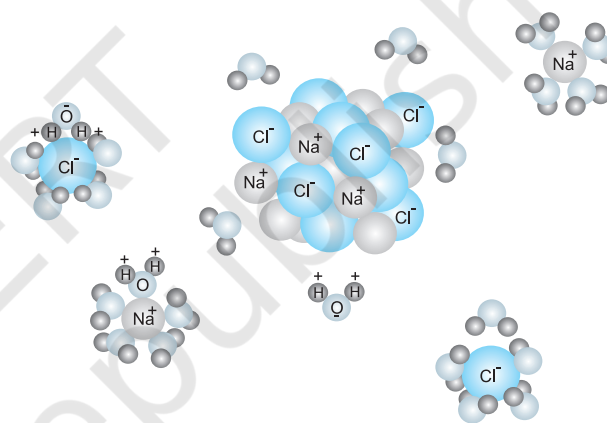

Fig.6.10 Dissolution of sodium chloride in water. Na^+ and Cl^- ions are stabilised by their hydration with polar water molecules.

Comparing, the ionization of hydrochloric acid with that of acetic acid in water we find that though both of them are polar covalent

Faraday was born near London into a family of very limited means. At the age of 14 he was an apprentice to a kind bookbinder who allowed Faraday to read the books he was binding. Through a fortunate chance he became laboratory assistant to Davy, and during 1813-4, Faraday accompanied him to the Continent. During this trip he gained much from the experience of coming into contact with many of the leading scientists of the time. In 1825, he succeeded Davy as Director of the Royal Institution laboratories, and in 1833 he also became the first Fullerian Professor of Chemistry. Faraday's first important work was on analytical chemistry. After 1821 much of his work was on electricity and magnetism and different electromagnetic phenomena. His ideas have led to the establishment of modern field theory. He discovered his two laws of electrolysis in 1834. Faraday was a very modest and kind hearted person. He declined all honours and avoided scientific controversies. He preferred to work alone and never had any assistant. He disseminated science in a variety of ways including his Friday evening discourses, which he founded at the Royal Institution. He has been very famous for his Christmas lecture on the 'Chemical History of a Candle'. He published nearly 450 scientific papers.



Michael Faraday
(1791-1867)

molecules, former is completely ionized into its constituent ions, while the latter is only partially ionized (< 5%). The extent to which ionization occurs depends upon the strength of the bond and the extent of solvation of ions produced. The terms dissociation and ionization have earlier been used with different meaning. Dissociation refers to the process of separation of ions in water already existing as such in the solid state of the solute, as in sodium chloride. On the other hand, ionization corresponds to a process in which a neutral molecule splits into charged ions in the solution. Here, we shall not distinguish between the two and use the two terms interchangeably.

6.10.1 Arrhenius Concept of Acids and Bases

According to Arrhenius theory, *acids are substances that dissociates in water to give hydrogen ions $H^+(aq)$ and bases are substances that produce hydroxyl ions $OH^-(aq)$* . The ionization of an acid $HX(aq)$ can be represented by the following equations:

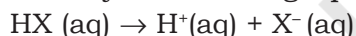

or

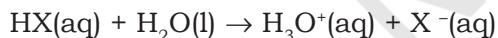

A bare proton, H^+ is very reactive and cannot exist freely in aqueous solutions. Thus, it bonds to the oxygen atom of a solvent water molecule to give *trigonal pyramidal hydronium ion*, $H_3O^+ \{[H(H_2O)]^+\}$ (see box). In this chapter we shall use $H^+(aq)$ and $H_3O^+(aq)$ interchangeably to mean the same i.e., a hydrated proton.

Similarly, a base molecule like MOH ionizes in aqueous solution according to the equation:

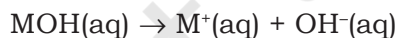

The hydroxyl ion also exists in the hydrated form in the aqueous solution. Arrhenius concept of acid and base, however, suffers from the limitation of being applicable only to aqueous solutions and also, does not account for the basicity of substances like, ammonia which do not possess a hydroxyl group.

Hydronium and Hydroxyl Ions

Hydrogen ion by itself is a bare proton with very small size ($\sim 10^{-15}$ m radius) and intense electric field, binds itself with the water molecule at one of the two available lone pairs on it giving H_3O^+ . This species has been detected in many compounds (e.g., $H_3O^+Cl^-$) in the solid state. In aqueous solution the hydronium ion is further hydrated to give species like $H_5O_2^+$, $H_7O_3^+$ and $H_9O_4^+$. Similarly the hydroxyl ion is hydrated to give several ionic species like $H_3O_2^-$, $H_5O_3^-$ and $H_7O_4^-$ etc.

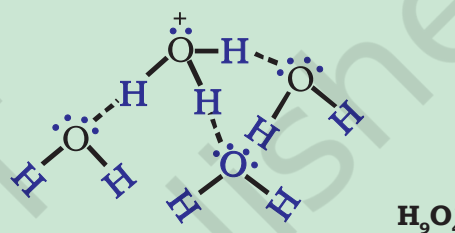

6.10.2 The Brønsted-Lowry Acids and Bases

The Danish chemist, Johannes Brønsted and the English chemist, Thomas M. Lowry gave a more general definition of acids and bases. According to Brønsted-Lowry theory, *acid is a substance that is capable of donating a hydrogen ion H^+ and bases are substances capable of accepting a hydrogen ion, H^+* . In short, acids are proton donors and bases are proton acceptors.

Consider the example of dissolution of NH_3 in H_2O represented by the following equation:

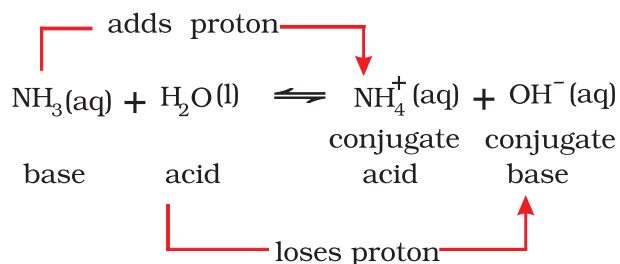

The basic solution is formed due to the presence of hydroxyl ions. In this reaction, water molecule acts as proton donor and ammonia molecule acts as proton acceptor and are thus, called Lowry-Brønsted acid and



Svante Arrhenius
(1859-1927)

Arrhenius was born near Uppsala, Sweden. He presented his thesis, on the conductivities of electrolyte solutions, to the University of Uppsala in 1884. For the next five years he travelled extensively and visited a number of research centers in Europe. In 1895 he was appointed professor of physics at the newly formed University of Stockholm, serving its rector from 1897 to 1902. From 1905 until his death he was Director of physical chemistry at the Nobel Institute in Stockholm. He continued to work for many years on electrolytic solutions. In 1899 he discussed the temperature dependence of reaction rates on the basis of an equation, now usually known as Arrhenius equation.

He worked in a variety of fields, and made important contributions to immunochemistry, cosmology, the origin of life, and the causes of ice age. He was the first to discuss the 'green house effect' calling by that name. He received Nobel Prize in Chemistry in 1903 for his theory of electrolytic dissociation and its use in the development of chemistry.

base, respectively. In the reverse reaction, H^+ is transferred from NH_4^+ to OH^- . In this case, NH_4^+ acts as a Brønsted acid while OH^- acted as a Brønsted base. The acid-base pair that differs only by one proton is called a **conjugate acid-base pair**. Therefore, OH^- is called the conjugate base of an acid H_2O and NH_4^+ is called conjugate acid of the base NH_3 . If Brønsted acid is a strong acid then **its conjugate base is a weak base and vice-versa**. It may be noted that conjugate acid has one extra proton and each conjugate base has one less proton.

Consider the example of ionization of hydrochloric acid in water. $HCl(aq)$ acts as an acid by donating a proton to H_2O molecule which acts as a base.

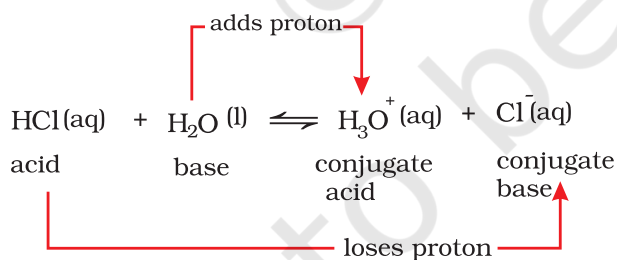

It can be seen in the above equation, that water acts as a base because it accepts the proton. The species H_3O^+ is produced when water accepts a proton from HCl . Therefore, Cl^- is a conjugate base of HCl and HCl is the conjugate acid of base Cl^- . Similarly, H_2O is a conjugate base of an acid H_3O^+ and H_3O^+ is a conjugate acid of base H_2O .

It is interesting to observe the dual role of water as an acid and a base. In case of reaction with HCl water acts as a base while

in case of ammonia it acts as an acid by donating a proton.

Problem 6.12

What will be the conjugate bases for the following Brønsted acids: HF , H_2SO_4 and HCO_3^- ?

Solution

The conjugate bases should have one proton less in each case and therefore the corresponding conjugate bases are: F^- , HSO_4^- and CO_3^{2-} respectively.

Problem 6.13

Write the conjugate acids for the following Brønsted bases: NH_2^- , NH_3 and $HCOO^-$.

Solution

The conjugate acid should have one extra proton in each case and therefore the corresponding conjugate acids are: NH_3 , NH_4^+ and $HCOOH$ respectively.

Problem 6.14

The species: H_2O , HCO_3^- , HSO_4^- and NH_3 can act both as Brønsted acids and bases. For each case give the corresponding conjugate acid and conjugate base.

Solution

The answer is given in the following Table:

Species	Conjugate acid	Conjugate base
H_2O	H_3O^+	OH^-
HCO_3^-	H_2CO_3	CO_3^{2-}
HSO_4^-	H_2SO_4	SO_4^{2-}
NH_3	NH_4^+	NH_2^-

6.10.3 Lewis Acids and Bases

G.N. Lewis in 1923 defined an *acid as a species which accepts electron pair and base which donates an electron pair*. As far as bases are concerned, there is not much difference between Brønsted-Lowry and Lewis concepts, as the base provides a lone pair in both the cases. However, in Lewis concept many acids do not have proton. A typical example is reaction of electron deficient species BF_3 with NH_3 .

BF_3 does not have a proton but still acts as an acid and reacts with NH_3 by accepting its lone pair of electrons. The reaction can be represented by,

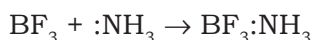

Electron deficient species like AlCl_3 , Co^{3+} , Mg^{2+} , etc. can act as Lewis acids while species like H_2O , NH_3 , OH^- etc. which can donate a pair of electrons, can act as Lewis bases.

Problem 6.15

Classify the following species into Lewis acids and Lewis bases and show how these act as such:

- (a) HO^- (b) F^- (c) H^+ (d) BCl_3

Solution

- (a) Hydroxyl ion is a Lewis base as it can donate an electron lone pair (:OH^-).
- (b) Fluoride ion acts as a Lewis base as it can donate any one of its four electron lone pairs.
- (c) A proton is a Lewis acid as it can accept a lone pair of electrons from bases like hydroxyl ion and fluoride ion.
- (d) BCl_3 acts as a Lewis acid as it can accept a lone pair of electrons from species like ammonia or amine molecules.

6.11 IONIZATION OF ACIDS AND BASES

Arrhenius concept of acids and bases becomes useful in case of ionization of acids and bases as mostly ionizations in chemical and biological systems occur in aqueous medium. Strong acids like perchloric acid

(HClO_4), hydrochloric acid (HCl), hydrobromic acid (HBr), hydroiodic acid (HI), nitric acid (HNO_3) and sulphuric acid (H_2SO_4) are termed *strong* because they are almost completely dissociated into their constituent ions in an aqueous medium, thereby acting as proton (H^+) donors. Similarly, strong bases like lithium hydroxide (LiOH), sodium hydroxide (NaOH), potassium hydroxide (KOH), caesium hydroxide (CsOH) and barium hydroxide (Ba(OH)_2) are almost completely dissociated into ions in an aqueous medium giving hydroxyl ions, OH^- . According to Arrhenius concept they are strong acids and bases as they are able to completely dissociate and produce H_3O^+ and OH^- ions respectively in the medium. Alternatively, the strength of an acid or base may also be gauged in terms of Brønsted-Lowry concept of acids and bases, wherein a strong acid means a good proton donor and a strong base implies a good proton acceptor. Consider, the acid-base dissociation equilibrium of a weak acid HA,

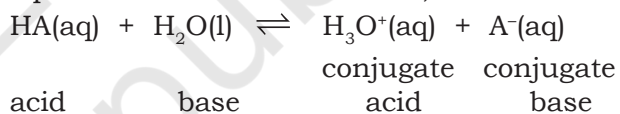

In section 6.10.2 we saw that acid (or base) dissociation equilibrium is dynamic involving a transfer of proton in forward and reverse directions. Now, the question arises that if the equilibrium is dynamic then with passage of time which direction is favoured? What is the driving force behind it? In order to answer these questions we shall deal into the issue of comparing the strengths of the two acids (or bases) involved in the dissociation equilibrium. Consider the two acids HA and H_3O^+ present in the above mentioned acid-dissociation equilibrium. We have to see which amongst them is a stronger proton donor. Whichever exceeds in its tendency of donating a proton over the other shall be termed as the stronger acid and the equilibrium will shift in the direction of weaker acid. Say, if HA is a stronger acid than H_3O^+ , then HA will donate protons and not H_3O^+ , and the solution will mainly contain A^- and H_3O^+ ions. The equilibrium moves in the direction of formation of weaker acid

and weaker base because **the stronger acid donates a proton to the stronger base.**

It follows that as a strong acid dissociates completely in water, the resulting base formed would be very weak i.e., **strong acids have very weak conjugate bases.** Strong acids like perchloric acid (HClO_4), hydrochloric acid (HCl), hydrobromic acid (HBr), hydroiodic acid (HI), nitric acid (HNO_3) and sulphuric acid (H_2SO_4) will give conjugate base ions ClO_4^- , Cl^- , Br^- , I^- , NO_3^- and HSO_4^- , which are much weaker bases than H_2O . Similarly a very strong base would give a very weak conjugate acid. On the other hand, a weak acid say HA is only partially dissociated in aqueous medium and thus, the solution mainly contains undissociated HA molecules. Typical weak acids are nitrous acid (HNO_2), hydrofluoric acid (HF) and acetic acid (CH_3COOH). It should be noted that the *weak acids have very strong conjugate bases.* For example, NH_2^- , O^{2-} and H^- are very good proton acceptors and thus, much stronger bases than H_2O .

Certain water soluble organic compounds like phenolphthalein and bromothymol blue behave as weak acids and exhibit different colours in their acid (HIn) and conjugate base (In^-) forms.

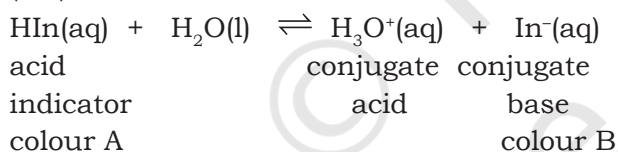

Such compounds are useful as indicators in acid-base titrations, and finding out H^+ ion concentration.

6.11.1 The Ionization Constant of Water and its Ionic Product

Some substances like water are unique in their ability of acting both as an acid and a base. We have seen this in case of water in section 6.10.2. In presence of an acid, HA it accepts a proton and acts as the base while in the presence of a base, B^- it acts as an acid by donating a proton. In pure water, one H_2O molecule donates proton and acts as an acid and another water molecules accepts a proton and acts as a base at the same time. The following equilibrium exists:

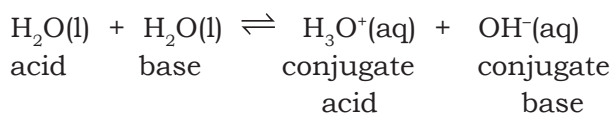

The dissociation constant is represented by,

$$K = \frac{[\text{H}_3\text{O}^+][\text{OH}^-]}{[\text{H}_2\text{O}]} \quad (6.26)$$

The concentration of water is omitted from the denominator as water is a pure liquid and its concentration remains constant. $[\text{H}_2\text{O}]$ is incorporated within the equilibrium constant to give a new constant, K_w , which is called the **ionic product of water.**

$$K_w = [\text{H}^+][\text{OH}^-] \quad (6.27)$$

The concentration of H^+ has been found out experimentally as $1.0 \times 10^{-7} \text{ M}$ at 298 K. And, as dissociation of water produces equal number of H^+ and OH^- ions, the concentration of hydroxyl ions, $[\text{OH}^-] = [\text{H}^+] = 1.0 \times 10^{-7} \text{ M}$. Thus, the value of K_w at 298K,

$$K_w = [\text{H}_3\text{O}^+][\text{OH}^-] = (1 \times 10^{-7})^2 = 1 \times 10^{-14} \text{ M}^2 \quad (6.28)$$

The value of K_w is temperature dependent as it is an equilibrium constant.

The density of pure water is 1000 g / L and its molar mass is 18.0 g / mol . From this the molarity of pure water can be given as, $[\text{H}_2\text{O}] = (1000 \text{ g / L})(1 \text{ mol} / 18.0 \text{ g}) = 55.55 \text{ M}$. Therefore, the ratio of dissociated water to that of undissociated water can be given as: $10^{-7} / (55.55) = 1.8 \times 10^{-9}$ or $\sim 2 \text{ in } 10^{-9}$ (thus, equilibrium lies mainly towards undissociated water)

We can distinguish acidic, neutral and basic aqueous solutions by the relative values of the H_3O^+ and OH^- concentrations:

$$\text{Acidic: } [\text{H}_3\text{O}^+] > [\text{OH}^-]$$

$$\text{Neutral: } [\text{H}_3\text{O}^+] = [\text{OH}^-]$$

$$\text{Basic : } [\text{H}_3\text{O}^+] < [\text{OH}^-]$$

6.11.2 The pH Scale

Hydronium ion concentration in molarity is more conveniently expressed on a logarithmic scale known as the **pH scale**. The pH of a solution is defined as the negative logarithm to base 10 of the activity (a_{H^+}) of hydrogen

ion. In dilute solutions (< 0.01 M), activity of hydrogen ion (H^+) is equal in magnitude to molarity represented by $[H^+]$. It should be noted that activity has no units and is defined as:

$$a_{H^+} = [H^+] / \text{mol L}^{-1}$$

From the definition of pH, the following can be written,

$$\text{pH} = -\log a_{H^+} = -\log \{[H^+] / \text{mol L}^{-1}\}$$

Thus, an acidic solution of HCl (10^{-2} M) will have a $\text{pH} = 2$. Similarly, a basic solution of NaOH having $[OH^-] = 10^{-4}$ M and $[H_3O^+] = 10^{-10}$ M will have a $\text{pH} = 10$. At 25°C , pure water has a concentration of hydrogen ions, $[H^+] = 10^{-7}$ M. Hence, the pH of pure water is given as:

$$\text{pH} = -\log(10^{-7}) = 7$$

Acidic solutions possess a concentration of hydrogen ions, $[H^+] > 10^{-7}$ M, while basic solutions possess a concentration of hydrogen ions, $[H^+] < 10^{-7}$ M. thus, we can summarise that

Acidic solution has $\text{pH} < 7$

Basic solution has $\text{pH} > 7$

Neutral solution has $\text{pH} = 7$

Now again, consider the equation (6.28) at 298 K

$$K_w = [H_3O^+] [OH^-] = 10^{-14}$$

Taking negative logarithm on both sides of equation, we obtain

$$\begin{aligned} -\log K_w &= -\log \{[H_3O^+] [OH^-]\} \\ &= -\log [H_3O^+] - \log [OH^-] \\ &= -\log 10^{-14} \end{aligned}$$

$$\text{p}K_w = \text{pH} + \text{pOH} = 14 \quad (6.29)$$

Note that although K_w may change with temperature the variations in pH with temperature are so small that we often ignore it.

$\text{p}K_w$ is a very important quantity for aqueous solutions and controls the relative concentrations of hydrogen and hydroxyl ions as their product is a constant. It should be noted that as the pH scale is logarithmic, a change in pH by just one unit also means change in $[H^+]$ by a factor of 10. Similarly,

when the hydrogen ion concentration, $[H^+]$ changes by a factor of 100, the value of pH changes by 2 units. Now you can realise why the change in pH with temperature is often ignored.

Measurement of pH of a solution is very essential as its value should be known when dealing with biological and cosmetic applications. The pH of a solution can be found roughly with the help of pH paper that has different colour in solutions of different pH. Now-a-days pH paper is available with four strips on it. The different strips have different colours (Fig. 6.11) at the same pH. The pH in the range of 1-14 can be determined with an accuracy of ~ 0.5 using pH paper.



Fig. 6.11 pH-paper with four strips that may have different colours at the same pH

For greater accuracy pH meters are used. pH meter is a device that measures the pH-dependent electrical potential of the test solution within 0.001 precision. pH meters of the size of a writing pen are now available in the market. The pH of some very common substances are given in Table 6.5 (page 195).

Problem 6.16

The concentration of hydrogen ion in a sample of soft drink is 3.8×10^{-3} M. what is its pH ?

Solution

$$\begin{aligned} \text{pH} &= -\log[3.8 \times 10^{-3}] \\ &= -\{\log[3.8] + \log[10^{-3}]\} \\ &= -\{(0.58) + (-3.0)\} = -\{-2.42\} = 2.42 \end{aligned}$$

Therefore, the pH of the soft drink is 2.42 and it can be inferred that it is acidic.

Problem 6.17

Calculate pH of a 1.0×10^{-8} M solution of HCl.

Table 6.5 The pH of Some Common Substances

Name of the Fluid	pH	Name of the Fluid	pH
Saturated solution of NaOH	~15	Black Coffee	5.0
0.1 M NaOH solution	13	Tomato juice	~4.2
Lime water	10.5	Soft drinks and vinegar	~3.0
Milk of magnesia	10	Lemon juice	~2.2
Egg white, sea water	7.8	Gastric juice	~1.2
Human blood	7.4	1M HCl solution	~0
Milk	6.8	Concentrated HCl	~-1.0
Human Saliva	6.4		

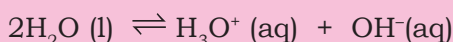
Solution

$$K_w = [\text{OH}^-][\text{H}_3\text{O}^+] = 10^{-14}$$

Let, $x = [\text{OH}^-] = [\text{H}_3\text{O}^+]$ from H_2O . The H_3O^+ concentration is generated (i) from the ionization of HCl dissolved i.e.,

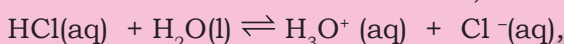

and (ii) from ionization of H_2O . In these very dilute solutions, both sources of H_3O^+ must be considered:

$$[\text{H}_3\text{O}^+] = 10^{-8} + x$$

$$K_w = (10^{-8} + x)(x) = 10^{-14}$$

$$\text{or } x^2 + 10^{-8}x - 10^{-14} = 0$$

$$[\text{OH}^-] = x = 9.5 \times 10^{-8}$$

$$\text{So, pOH} = 7.02 \text{ and pH} = 6.98$$

6.11.3 Ionization Constants of Weak Acids

Consider a weak acid HX that is partially ionized in the aqueous solution. The equilibrium can be expressed by:

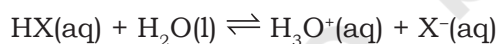

Initial

concentration (M)

$$c \qquad 0 \qquad 0$$

Let α be the extent of ionization

Change (M)

$$-c\alpha \qquad +c\alpha \qquad +c\alpha$$

Equilibrium concentration (M)

$$c-c\alpha \qquad c\alpha \qquad c\alpha$$

Here, c = initial concentration of the undissociated acid, HX at time, $t = 0$. α = extent up to which HX is ionized into ions. Using these notations, we can derive the

equilibrium constant for the above discussed acid-dissociation equilibrium:

$$K_a = c^2\alpha^2 / c(1-\alpha) = c\alpha^2 / 1-\alpha$$

K_a is called the **dissociation or ionization constant** of acid HX. It can be represented alternatively in terms of molar concentration as follows,

$$K_a = [\text{H}^+][\text{X}^-] / [\text{HX}] \qquad (6.30)$$

At a given temperature T , K_a is a measure of the strength of the acid HX i.e., larger the value of K_a , the stronger is the acid. K_a is a dimensionless quantity with the understanding that the standard state concentration of all species is 1M.

The values of the ionization constants of some selected weak acids are given in Table 6.6.

Table 6.6 The Ionization Constants of Some Selected Weak Acids (at 298K)

Acid	Ionization Constant, K_a
Hydrofluoric Acid (HF)	3.5×10^{-4}
Nitrous Acid (HNO_2)	4.5×10^{-4}
Formic Acid (HCOOH)	1.8×10^{-4}
Niacin ($\text{C}_5\text{H}_4\text{NCOOH}$)	1.5×10^{-5}
Acetic Acid (CH_3COOH)	1.74×10^{-5}
Benzoic Acid ($\text{C}_6\text{H}_5\text{COOH}$)	6.5×10^{-5}
Hypochlorous Acid (HClO)	3.0×10^{-8}
Hydrocyanic Acid (HCN)	4.9×10^{-10}
Phenol ($\text{C}_6\text{H}_5\text{OH}$)	1.3×10^{-10}

The pH scale for the hydrogen ion concentration has been so useful that besides $\text{p}K_w$, it has been extended to other species and

quantities. Thus, we have:

$$pK_a = -\log(K_a) \quad (6.31)$$

Knowing the ionization constant, K_a of an acid and its initial concentration, c , it is possible to calculate the equilibrium concentration of all species and also the degree of ionization of the acid and the pH of the solution.

A general step-wise approach can be adopted to evaluate the pH of the weak electrolyte as follows:

Step 1. The species present before dissociation are identified as Brønsted-Lowry acids/bases.

Step 2. Balanced equations for all possible reactions i.e., with a species acting both as acid as well as base are written.

Step 3. The reaction with the higher K_a is identified as the primary reaction whilst the other is a subsidiary reaction.

Step 4. Enlist in a tabular form the following values for each of the species in the primary reaction

- Initial concentration, c .
- Change in concentration on proceeding to equilibrium in terms of α , degree of ionization.
- Equilibrium concentration.

Step 5. Substitute equilibrium concentrations into equilibrium constant equation for principal reaction and solve for α .

Step 6. Calculate the concentration of species in principal reaction.

Step 7. Calculate $\text{pH} = -\log[\text{H}_3\text{O}^+]$

The above mentioned methodology has been elucidated in the following examples.

Problem 6.18

The ionization constant of HF is 3.2×10^{-4} . Calculate the degree of dissociation of HF in its 0.02 M solution. Calculate the concentration of all species present (H_3O^+ , F^- and HF) in the solution and its pH.

Solution

The following proton transfer reactions are possible:

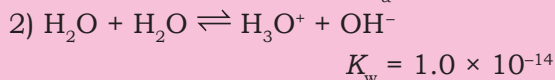
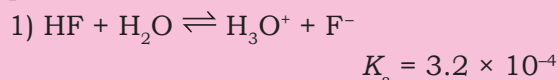

As $K_a \gg K_w$, [1] is the principle reaction.



Initial

concentration (M)

$$0.02 \qquad 0 \qquad 0$$

Change (M)

$$-0.02\alpha \qquad +0.02\alpha \qquad +0.02\alpha$$

Equilibrium

concentration (M)

$$0.02 - 0.02\alpha \qquad 0.02\alpha \qquad 0.02\alpha$$

Substituting equilibrium concentrations in the equilibrium reaction for principal reaction gives:

$$K_a = \frac{(0.02\alpha)^2}{(0.02 - 0.02\alpha)}$$

$$= 0.02 \alpha^2 / (1 - \alpha) = 3.2 \times 10^{-4}$$

We obtain the following quadratic equation:

$$\alpha^2 + 1.6 \times 10^{-2}\alpha - 1.6 \times 10^{-2} = 0$$

The quadratic equation in α can be solved and the two values of the roots are:

$$\alpha = +0.12 \text{ and } -0.12$$

The negative root is not acceptable and hence,

$$\alpha = 0.12$$

This means that the degree of ionization, $\alpha = 0.12$, then equilibrium concentrations of other species viz., HF, F^- and H_3O^+ are given by:

$$[\text{H}_3\text{O}^+] = [\text{F}^-] = c\alpha = 0.02 \times 0.12$$

$$= 2.4 \times 10^{-3} \text{ M}$$

$$[\text{HF}] = c(1 - \alpha) = 0.02 (1 - 0.12)$$

$$= 17.6 \times 10^{-3} \text{ M}$$

$$\text{pH} = -\log[\text{H}^+] = -\log(2.4 \times 10^{-3}) = 2.62$$

Problem 6.19

The pH of 0.1M monobasic acid is 4.50. Calculate the concentration of species H^+ , A^-

and HA at equilibrium. Also, determine the value of K_a and pK_a of the monobasic acid.

Solution

$$\text{pH} = -\log [\text{H}^+]$$

$$\begin{aligned}\text{Therefore, } [\text{H}^+] &= 10^{-\text{pH}} = 10^{-4.50} \\ &= 3.16 \times 10^{-5}\end{aligned}$$

$$[\text{H}^+] = [\text{A}^-] = 3.16 \times 10^{-5}$$

$$\text{Thus, } K_a = [\text{H}^+][\text{A}^-] / [\text{HA}]$$

$$[\text{HA}]_{\text{eqbm}} = 0.1 - (3.16 \times 10^{-5}) \approx 0.1$$

$$K_a = (3.16 \times 10^{-5})^2 / 0.1 = 1.0 \times 10^{-8}$$

$$\text{p}K_a = -\log(10^{-8}) = 8$$

Alternatively, “Percent dissociation” is another useful method for measure of strength of a weak acid and is given as:

Percent dissociation

$$= \frac{[\text{HA}]_{\text{dissociated}}}{[\text{HA}]_{\text{initial}}} \times 100\% \quad (6.32)$$

Problem 6.20

Calculate the pH of 0.08M solution of hypochlorous acid, HOCl. The ionization constant of the acid is 2.5×10^{-5} . Determine the percent dissociation of HOCl.

Solution



Initial concentration (M)		
0.08	0	0

Change to reach equilibrium concentration (M)		
-x	+x	+x

equilibrium concentration (M)		
0.08 - x	x	x

$$\begin{aligned}K_a &= \frac{[\text{H}_3\text{O}^+][\text{ClO}^-]}{[\text{HOCl}]}\end{aligned}$$

$$= \frac{x^2}{(0.08 - x)}$$

As $x \ll 0.08$, therefore $0.08 - x \approx 0.08$

$$x^2 / 0.08 = 2.5 \times 10^{-5}$$

$$x^2 = 2.0 \times 10^{-6}, \text{ thus, } x = 1.41 \times 10^{-3}$$

$$[\text{H}^+] = 1.41 \times 10^{-3} \text{ M.}$$

Therefore,

Percent dissociation

$$= \left\{ \frac{[\text{HOCl}]_{\text{dissociated}}}{[\text{HOCl}]_{\text{initial}}} \right\} \times 100$$

$$= 1.41 \times 10^{-3} \times 10^2 / 0.08 = 1.76 \%$$

$$\text{pH} = -\log(1.41 \times 10^{-3}) = 2.85.$$

6.11.4 Ionization of Weak Bases

The ionization of base MOH can be represented by equation:



In a weak base there is partial ionization of MOH into M^+ and OH^- , the case is similar to that of acid-dissociation equilibrium. The equilibrium constant for base ionization is called **base ionization constant** and is represented by K_b . It can be expressed in terms of concentration in molarity of various species in equilibrium by the following equation:

$$K_b = \frac{[\text{M}^+][\text{OH}^-]}{[\text{MOH}]} \quad (6.33)$$

Alternatively, if c = initial concentration of base and α = degree of ionization of base i.e. the extent to which the base ionizes. When equilibrium is reached, the equilibrium constant can be written as:

$$K_b = (c\alpha)^2 / c(1-\alpha) = c\alpha^2 / (1-\alpha)$$

The values of the ionization constants of some selected weak bases, K_b are given in Table 6.7.

Table 6.7 The Values of the Ionization Constant of Some Weak Bases at 298 K

Base	K_b
Dimethylamine, $(\text{CH}_3)_2\text{NH}$	5.4×10^{-4}
Triethylamine, $(\text{C}_2\text{H}_5)_3\text{N}$	6.45×10^{-5}
Ammonia, NH_3 or NH_4OH	1.77×10^{-5}
Quinine, (A plant product)	1.10×10^{-6}
Pyridine, $\text{C}_5\text{H}_5\text{N}$	1.77×10^{-9}
Aniline, $\text{C}_6\text{H}_5\text{NH}_2$	4.27×10^{-10}
Urea, $\text{CO}(\text{NH}_2)_2$	1.3×10^{-14}

Many organic compounds like *amines* are weak bases. Amines are derivatives of ammonia in which one or more hydrogen atoms are replaced by another group. For example, methylamine, codeine, quinine and

nicotine all behave as very weak bases due to their very small K_b . Ammonia produces OH^- in aqueous solution:

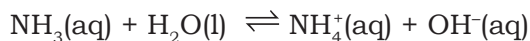

The pH scale for the hydrogen ion concentration has been extended to get:

$$\text{p}K_b = -\log(K_b) \quad (6.34)$$

Problem 6.21

The pH of 0.004M hydrazine solution is 9.7. Calculate its ionization constant K_b and $\text{p}K_b$.

Solution

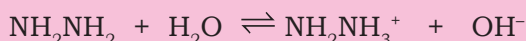

From the pH we can calculate the hydrogen ion concentration. Knowing hydrogen ion concentration and the ionic product of water we can calculate the concentration of hydroxyl ions. Thus we have:

$$[\text{H}^+] = \text{antilog}(-\text{pH})$$

$$= \text{antilog}(-9.7) = 1.67 \times 10^{-10}$$

$$[\text{OH}^-] = K_w / [\text{H}^+] = 1 \times 10^{-14} / 1.67 \times 10^{-10} \\ = 5.98 \times 10^{-5}$$

The concentration of the corresponding hydrazinium ion is also the same as that of hydroxyl ion. The concentration of both these ions is very small so the concentration of the undissociated base can be taken equal to 0.004M.

Thus,

$$K_b = \frac{[\text{NH}_2\text{NH}_3^+][\text{OH}^-]}{[\text{NH}_2\text{NH}_2]} \\ = \frac{(5.98 \times 10^{-5})^2}{0.004} = 8.96 \times 10^{-7} \\ \text{p}K_b = -\log K_b = -\log(8.96 \times 10^{-7}) = 6.04.$$

Problem 6.22

Calculate the pH of the solution in which 0.2M NH_4Cl and 0.1M NH_3 are present. The $\text{p}K_b$ of ammonia solution is 4.75.

Solution

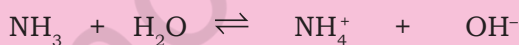

The ionization constant of NH_3 ,

$$K_b = \text{antilog}(-\text{p}K_b) \text{ i.e.}$$

$$K_b = 10^{-4.75} = 1.77 \times 10^{-5} \text{ M}$$

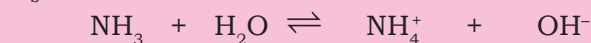

Initial concentration (M)

$$0.10 \qquad \qquad 0.20 \qquad \qquad 0$$

Change to reach equilibrium (M)

$$-x \qquad \qquad +x \qquad \qquad +x$$

At equilibrium (M)

$$0.10 - x \qquad \qquad 0.20 + x \qquad \qquad x$$

$$K_b = \frac{[\text{NH}_4^+][\text{OH}^-]}{[\text{NH}_3]} \\ = \frac{(0.20 + x)(x)}{(0.1 - x)} = 1.77 \times 10^{-5}$$

As K_b is small, we can neglect x in comparison to 0.1M and 0.2M. Thus,

$$[\text{OH}^-] = x = 0.88 \times 10^{-5}$$

$$\text{Therefore, } [\text{H}^+] = 1.12 \times 10^{-9}$$

$$\text{pH} = -\log[\text{H}^+] = 8.95.$$

6.11.5 Relation between K_a and K_b

As seen earlier in this chapter, K_a and K_b represent the strength of an acid and a base, respectively. In case of a conjugate acid-base pair, they are related in a simple manner so that if one is known, the other can be deduced. Considering the example of NH_4^+ and NH_3 we see,

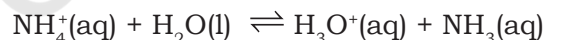

$$K_a = \frac{[\text{H}_3\text{O}^+][\text{NH}_3]}{[\text{NH}_4^+]} = 5.6 \times 10^{-10}$$

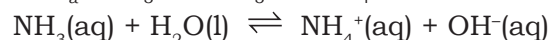

$$K_b = \frac{[\text{NH}_4^+][\text{OH}^-]}{[\text{NH}_3]} = 1.8 \times 10^{-5}$$

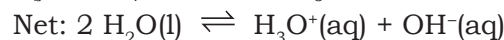

$$K_w = [\text{H}_3\text{O}^+][\text{OH}^-] = 1.0 \times 10^{-14} \text{ M}$$

Where, K_a represents the strength of NH_4^+ as an acid and K_b represents the strength of NH_3 as a base.

It can be seen from the net reaction that the equilibrium constant is equal to the product of equilibrium constants K_a and K_b for the reactions added. Thus,

$$K_a \times K_b = \left\{ \frac{[\text{H}_3\text{O}^+][\text{NH}_3]}{[\text{NH}_4^+]} \right\} \times \left\{ \frac{[\text{NH}_4^+][\text{OH}^-]}{[\text{NH}_3]} \right\}$$

$$= [\text{H}_3\text{O}^+][\text{OH}^-] = K_w$$

$$= (5.6 \times 10^{-10}) \times (1.8 \times 10^{-5}) = 1.0 \times 10^{-14} \text{ M}$$

This can be extended to make a generalisation. **The equilibrium constant for a net reaction obtained after adding two (or more) reactions equals the product of the equilibrium constants for individual reactions:**

$$K_{\text{NET}} = K_1 \times K_2 \times \dots \quad (6.35)$$

Similarly, in case of a conjugate acid-base pair,

$$K_a \times K_b = K_w \quad (6.36)$$

Knowing one, the other can be obtained. It should be noted that a *strong acid will have a weak conjugate base and vice-versa*.

Alternatively, the above expression $K_w = K_a \times K_b$, can also be obtained by considering the base-dissociation equilibrium reaction:

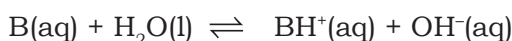

$$K_b = \frac{[\text{BH}^+][\text{OH}^-]}{[\text{B}]}$$

As the concentration of water remains constant it has been omitted from the denominator and incorporated within the dissociation constant. Then multiplying and dividing the above expression by $[\text{H}^+]$, we get:

$$\begin{aligned} K_b &= \frac{[\text{BH}^+][\text{OH}^-][\text{H}^+]}{[\text{B}][\text{H}^+]} \\ &= \frac{[\text{OH}^-][\text{H}^+]}{[\text{BH}^+]} \times \frac{[\text{BH}^+]}{[\text{B}][\text{H}^+]} \\ &= K_w / K_a \end{aligned}$$

$$\text{or } K_a \times K_b = K_w$$

It may be noted that if we take negative logarithm of both sides of the equation, then $\text{p}K$ values of the conjugate acid and base are related to each other by the equation:

$$\text{p}K_a + \text{p}K_b = \text{p}K_w = 14 \quad (\text{at } 298\text{K})$$

Problem 6.23

Determine the degree of ionization and pH of a 0.05M of ammonia solution. The ionization constant of ammonia can be taken from Table 6.7. Also, calculate the ionization constant of the conjugate acid of ammonia.

Solution

The ionization of NH_3 in water is represented by equation:

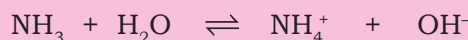

We use equation (6.33) to calculate hydroxyl ion concentration,

$$[\text{OH}^-] = c \alpha = 0.05 \alpha$$

$$K_b = 0.05 \alpha^2 / (1 - \alpha)$$

The value of α is small, therefore the quadratic equation can be simplified by neglecting α in comparison to 1 in the denominator on right hand side of the equation,

Thus,

$$\begin{aligned} K_b &= c \alpha^2 \quad \text{or} \quad \alpha = \sqrt{(1.77 \times 10^{-5} / 0.05)} \\ &= 0.018. \end{aligned}$$

$$[\text{OH}^-] = c \alpha = 0.05 \times 0.018 = 9.4 \times 10^{-4}\text{M}.$$

$$\begin{aligned} [\text{H}^+] &= K_w / [\text{OH}^-] = 10^{-14} / (9.4 \times 10^{-4}) \\ &= 1.06 \times 10^{-11} \end{aligned}$$

$$\text{pH} = -\log(1.06 \times 10^{-11}) = 10.97.$$

Now, using the relation for conjugate acid-base pair,

$$K_a \times K_b = K_w$$

using the value of K_b of NH_3 from Table 6.7.

We can determine the concentration of conjugate acid NH_4^+

$$\begin{aligned} K_a &= K_w / K_b = 10^{-14} / 1.77 \times 10^{-5} \\ &= 5.64 \times 10^{-10}. \end{aligned}$$

6.11.6 Di- and Polybasic Acids and Di- and Polyacidic Bases

Some of the acids like oxalic acid, sulphuric acid and phosphoric acids have more than one ionizable proton per molecule of the acid. Such acids are known as polybasic or polyprotic acids.

The ionization reactions for example for a *dibasic acid* H_2X are represented by the equations:

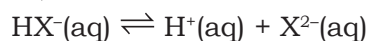
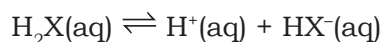

And the corresponding equilibrium constants are given below:

$$K_{a_1} = \frac{[\text{H}^+][\text{HX}^-]}{[\text{H}_2\text{X}]} \quad \text{and}$$

$$K_{a_2} = \frac{[H^+][X^{2-}]}{[HX]}$$

Here, K_{a_1} and K_{a_2} are called the first and second ionization constants respectively of the acid H_2X . Similarly, for tribasic acids like H_3PO_4 we have three ionization constants. The values of the ionization constants for some common polyprotic acids are given in Table 6.8.

Table 6.8 The Ionization Constants of Some Common Polyprotic Acids (298K)

Acid	K_{a_1}	K_{a_2}	K_{a_3}
Oxalic Acid	5.9×10^{-2}	6.4×10^{-5}	
Ascorbic Acid	7.4×10^{-4}	1.6×10^{-12}	
Sulphurous Acid	1.7×10^{-2}	6.4×10^{-8}	
Sulphuric Acid	Very large	1.2×10^{-2}	
Carbonic Acid	4.3×10^{-7}	5.6×10^{-11}	
Citric Acid	7.4×10^{-4}	1.7×10^{-5}	4.0×10^{-7}
Phosphoric Acid	7.5×10^{-3}	6.2×10^{-8}	4.2×10^{-13}

It can be seen that higher order ionization constants (K_{a_2} , K_{a_3}) are smaller than the lower order ionization constant (K_{a_1}) of a polyprotic acid. The reason for this is that it is more difficult to remove a positively charged proton from a negative ion due to electrostatic forces. This can be seen in the case of removing a proton from the uncharged H_2CO_3 as compared from a negatively charged HCO_3^- . Similarly, it is more difficult to remove a proton from a doubly charged HPO_4^{2-} anion as compared to $H_2PO_4^-$.

Polyprotic acid solutions contain a mixture of acids like H_2A , HA^- and A^{2-} in case of a diprotic acid. H_2A being a strong acid, the primary reaction involves the dissociation of H_2A , and H_3O^+ in the solution comes mainly from the first dissociation step.

6.11.7 Factors Affecting Acid Strength

Having discussed quantitatively the strengths of acids and bases, we come to a stage where we can calculate the pH of a given acid solution. But, the curiosity rises about why should some acids be stronger than others? What factors are responsible for making them stronger? The answer lies in its being a complex phenomenon. But, broadly speaking we can say that the extent of dissociation of an acid depends on the **strength** and **polarity** of the H-A bond.

In general, when strength of H-A bond decreases, that is, the energy required to break the bond decreases, HA becomes a stronger acid. Also, when the H-A bond becomes more polar i.e., the electronegativity difference between the atoms H and A increases and there is marked charge separation, cleavage of the bond becomes easier thereby increasing the acidity.

But it should be noted that while comparing elements in the same *group* of the periodic table, H-A bond strength is a more important factor in determining acidity than its polar nature. As the size of A increases down the group, H-A bond strength decreases and so the acid strength increases. For example,

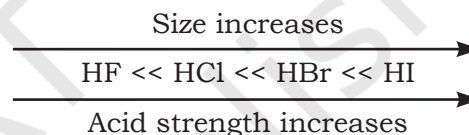

Similarly, H_2S is stronger acid than H_2O .

But, when we discuss elements in the same *row* of the periodic table, H-A bond polarity becomes the deciding factor for determining the acid strength. As the electronegativity of A increases, the strength of the acid also increases. For example,

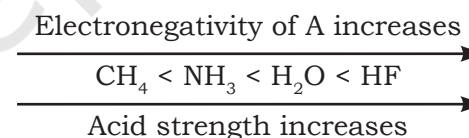

6.11.8 Common Ion Effect in the Ionization of Acids and Bases

Consider an example of acetic acid dissociation equilibrium represented as:

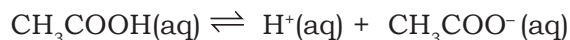

$$K_a = \frac{[H^+][Ac^-]}{[HAc]}$$

Addition of acetate ions to an acetic acid solution results in decreasing the concentration of hydrogen ions, $[H^+]$. Also, if H^+ ions are added from an external source then the equilibrium moves in the direction of undissociated acetic acid i.e., in a direction of reducing the concentration of hydrogen ions, $[H^+]$. This phenomenon is an example

of **common ion effect**. It can be defined as a shift in equilibrium on adding a substance that provides more of an ionic species already present in the dissociation equilibrium. Thus, we can say that common ion effect is a phenomenon based on the Le Chatelier's principle discussed in section 6.8.

In order to evaluate the pH of the solution resulting on addition of 0.05M acetate ion to 0.05M acetic acid solution, we shall consider the acetic acid dissociation equilibrium once again,

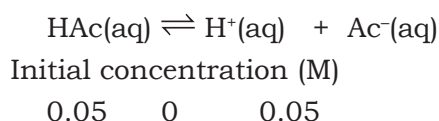

Let x be the extent of ionization of acetic acid.

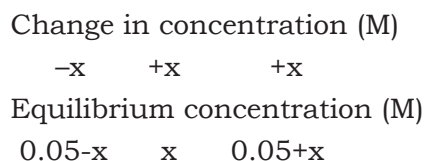

Therefore,

$$K_a = [\text{H}^{\text{+}}][\text{Ac}^{-}] / [\text{HAc}] = \{(0.05+x)(x)\} / (0.05-x)$$

As K_a is small for a very weak acid, $x \ll 0.05$.

$$\text{Hence, } (0.05 + x) \approx (0.05 - x) \approx 0.05$$

Thus,

$$1.8 \times 10^{-5} = (x)(0.05 + x) / (0.05 - x)$$

$$= x(0.05) / (0.05) = x = [\text{H}^{\text{+}}] = 1.8 \times 10^{-5} \text{M}$$

$$\text{pH} = -\log(1.8 \times 10^{-5}) = 4.74$$

Problem 6.24

Calculate the pH of a 0.10M ammonia solution. Calculate the pH after 50.0 mL of this solution is treated with 25.0 mL of 0.10M HCl. The dissociation constant of ammonia, $K_b = 1.77 \times 10^{-5}$

Solution



$$K_b = [\text{NH}_4^{\text{+}}][\text{OH}^{-}] / [\text{NH}_3] = 1.77 \times 10^{-5}$$

Before neutralization,

$$[\text{NH}_4^{\text{+}}] = [\text{OH}^{-}] = x$$

$$[\text{NH}_3] = 0.10 - x \approx 0.10$$

$$x^2 / 0.10 = 1.77 \times 10^{-5}$$

$$\text{Thus, } x = 1.33 \times 10^{-3} = [\text{OH}^{-}]$$

$$\text{Therefore, } [\text{H}^{\text{+}}] = K_w / [\text{OH}^{-}] = 10^{-14} /$$

$$(1.33 \times 10^{-3}) = 7.51 \times 10^{-12}$$

$$\text{pH} = -\log(7.5 \times 10^{-12}) = 11.12$$

On addition of 25 mL of 0.1M HCl solution (i.e., 2.5 mmol of HCl) to 50 mL of 0.1M ammonia solution (i.e., 5 mmol of NH_3), 2.5 mmol of ammonia molecules are neutralized. The resulting 75 mL solution contains the remaining unneutralized 2.5 mmol of NH_3 molecules and 2.5 mmol of $\text{NH}_4^{\text{+}}$.

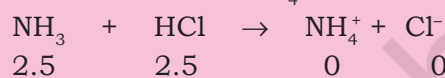

At equilibrium



The resulting 75 mL of solution contains 2.5 mmol of $\text{NH}_4^{\text{+}}$ ions (i.e., 0.033 M) and 2.5 mmol (i.e., 0.033 M) of unneutralised NH_3 molecules. This NH_3 exists in the following equilibrium:

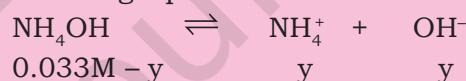

$$\text{where, } y = [\text{OH}^{-}] = [\text{NH}_4^{\text{+}}]$$

The final 75 mL solution after neutralisation already contains 2.5 mmol $\text{NH}_4^{\text{+}}$ ions (i.e. 0.033M), thus total concentration of $\text{NH}_4^{\text{+}}$ ions is given as:

$$[\text{NH}_4^{\text{+}}] = 0.033 + y$$

As y is small, $[\text{NH}_4\text{OH}] \approx 0.033 \text{ M}$ and $[\text{NH}_4^{\text{+}}] \approx 0.033 \text{ M}$.

We know,

$$K_b = [\text{NH}_4^{\text{+}}][\text{OH}^{-}] / [\text{NH}_4\text{OH}]$$

$$= y(0.033) / (0.033) = 1.77 \times 10^{-5} \text{ M}$$

$$\text{Thus, } y = 1.77 \times 10^{-5} = [\text{OH}^{-}]$$

$$[\text{H}^{\text{+}}] = 10^{-14} / 1.77 \times 10^{-5} = 0.56 \times 10^{-9}$$

$$\text{Hence, pH} = 9.24$$

6.11.9 Hydrolysis of Salts and the pH of their Solutions

Salts formed by the reactions between acids and bases in definite proportions, undergo ionization in water. The cations/anions

formed on ionization of salts either exist as hydrated ions in aqueous solutions or interact with water to reform corresponding acids/bases depending upon the nature of salts. The later process of interaction between water and cations/anions or both of salts is called hydrolysis. The pH of the solution gets affected by this interaction. The cations (e.g., Na⁺, K⁺, Ca²⁺, Ba²⁺, etc.) of strong bases and anions (e.g., Cl⁻, Br⁻, NO₃⁻, ClO₄⁻ etc.) of strong acids simply get hydrated but do not hydrolyse, and therefore the solutions of salts formed from strong acids and bases are neutral i.e., their pH is 7. However, the other category of salts do undergo hydrolysis.

We now consider the hydrolysis of the salts of the following types :

- (i) salts of weak acid and strong base e.g., CH₃COONa.
- (ii) salts of strong acid and weak base e.g., NH₄Cl, and
- (iii) salts of weak acid and weak base, e.g., CH₃COONH₄.

In the first case, CH₃COONa being a salt of weak acid, CH₃COOH and strong base, NaOH gets completely ionised in aqueous solution.

$$\text{CH}_3\text{COONa}(\text{aq}) \rightarrow \text{CH}_3\text{COO}^-(\text{aq}) + \text{Na}^+(\text{aq})$$

Acetate ion thus formed undergoes hydrolysis in water to give acetic acid and OH⁻ ions



Acetic acid being a weak acid ($K_a = 1.8 \times 10^{-5}$) remains mainly unionised in solution. This results in increase of OH⁻ ion concentration in solution making it alkaline. The pH of such a solution is more than 7.

Similarly, NH₄Cl formed from weak base, NH₄OH and strong acid, HCl, in water dissociates completely.



Ammonium ions undergo hydrolysis with water to form NH₄OH and H⁺ ions

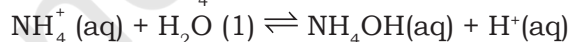

Ammonium hydroxide is a weak base ($K_b = 1.77 \times 10^{-5}$) and therefore remains almost unionised in solution. This results in

increased of H⁺ ion concentration in solution making the solution acidic. Thus, the pH of NH₄Cl solution in water is less than 7.

Consider the hydrolysis of CH₃COONH₄ salt formed from weak acid and weak base. The ions formed undergo hydrolysis as follow:

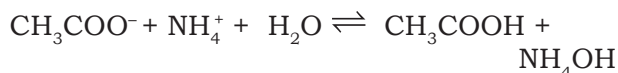

CH₃COOH and NH₄OH, also remain into partially dissociated form:

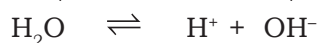
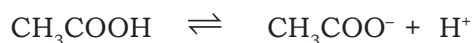

Without going into detailed calculation, it can be said that degree of hydrolysis is independent of concentration of solution, and pH of such solutions is determined by their pK values:

$$\text{pH} = 7 + \frac{1}{2} (\text{p}K_a - \text{p}K_b) \quad (6.38)$$

The pH of solution can be greater than 7, if the difference is positive and it will be less than 7, if the difference is negative.

Problem 6.25

The pK_a of acetic acid and pK_b of ammonium hydroxide are 4.76 and 4.75 respectively. Calculate the pH of ammonium acetate solution.

Solution

$$\begin{aligned} \text{pH} &= 7 + \frac{1}{2} [\text{p}K_a - \text{p}K_b] \\ &= 7 + \frac{1}{2} [4.76 - 4.75] \\ &= 7 + \frac{1}{2} [0.01] = 7 + 0.005 = 7.005 \end{aligned}$$

6.12 BUFFER SOLUTIONS

Many body fluids e.g., blood or urine have definite pH and any deviation in their pH indicates malfunctioning of the body. The control of pH is also very important in many chemical and biochemical processes. Many medical and cosmetic formulations require that these be kept and administered at a particular pH. **The solutions which resist change in pH on dilution or with the addition of small amounts of acid or alkali are called Buffer Solutions.** Buffer

solutions of known pH can be prepared from the knowledge of pK_a of the acid or pK_b of base and by controlling the ratio of the salt and acid or salt and base. A mixture of acetic acid and sodium acetate acts as buffer solution around pH 4.75 and a mixture of ammonium chloride and ammonium hydroxide acts as a buffer around pH 9.25. You will learn more about buffer solutions in higher classes.

6.12.1 Designing Buffer Solution

Knowledge of pK_a , pK_b and equilibrium constant help us to prepare the buffer solution of known pH. Let us see how we can do this.

Preparation of Acidic Buffer

To prepare a buffer of acidic pH we use weak acid and its salt formed with strong base. We develop the equation relating the pH, the equilibrium constant, K_a of weak acid and ratio of concentration of weak acid and its conjugate base. For the general case where the weak acid HA ionises in water,

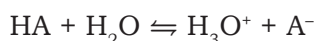

For which we can write the expression

$$K_a = \frac{[\text{H}_3\text{O}^+][\text{A}^-]}{[\text{HA}]}$$

Rearranging the expression we have,

$$[\text{H}_3\text{O}^+] = K_a \frac{[\text{HA}]}{[\text{A}^-]}$$

Taking logarithm on both the sides and rearranging the terms we get —

$$pK_a = \text{pH} - \log \frac{[\text{A}^-]}{[\text{HA}]}$$

Or

$$\text{pH} = pK_a + \log \frac{[\text{A}^-]}{[\text{HA}]} \quad (6.39)$$

$$\text{pH} = pK_a + \log \frac{[\text{Conjugate base, A}^-]}{[\text{Acid, HA}]} \quad (6.40)$$

The expression (6.40) is known as **Henderson-Hasselbalch equation**. The quantity $\frac{[\text{A}^-]}{[\text{HA}]}$ is the ratio of concentration of conjugate base (anion) of the acid and the

acid present in the mixture. Since acid is a weak acid, it ionises to a very little extent and concentration of [HA] is negligibly different from concentration of acid taken to form buffer. Also, most of the conjugate base, $[\text{A}^-]$, comes from the ionisation of salt of the acid. Therefore, the concentration of conjugate base will be negligibly different from the concentration of salt. Thus, equation (6.40) takes the form:

$$\text{pH} = pK_a + \log \frac{[\text{Salt}]}{[\text{Acid}]}$$

In the equation (6.39), if the concentration of $[\text{A}^-]$ is equal to the concentration of [HA], then $\text{pH} = pK_a$ because value of $\log 1$ is zero. Thus if we take molar concentration of acid and salt (conjugate base) same, the pH of the buffer solution will be equal to the pK_a of the acid. So for preparing the buffer solution of the required pH we select that acid whose pK_a is close to the required pH. For acetic acid pK_a value is 4.76, therefore pH of the buffer solution formed by acetic acid and sodium acetate taken in equal molar concentration will be around 4.76.

A similar analysis of a buffer made with a weak base and its conjugate acid leads to the result,

$$\text{pOH} = pK_b + \log \frac{[\text{Conjugate acid, BH}^+]}{[\text{Base, B}]} \quad (6.41)$$

pH of the buffer solution can be calculated by using the equation $\text{pH} + \text{pOH} = 14$.

We know that $\text{pH} + \text{pOH} = pK_w$ and $pK_a + pK_b = pK_w$. On putting these values in equation (6.41) it takes the form as follows:

$$pK_w - \text{pH} = pK_w - pK_a + \log \frac{[\text{Conjugate acid, BH}^+]}{[\text{Base, B}]}$$

or

$$\text{pH} = pK_a + \log \frac{[\text{Conjugate acid, BH}^+]}{[\text{Base, B}]} \quad (6.42)$$

If molar concentration of base and its conjugate acid (cation) is same then pH of the buffer solution will be same as pK_a for the base. pK_a value for ammonia is 9.25; therefore a buffer of pH close to 9.25 can be obtained by taking ammonia solution and ammonium

chloride solution of same molar concentration. For a buffer solution formed by ammonium chloride and ammonium hydroxide, equation (6.42) becomes:

$$\text{pH} = 9.25 + \log \frac{[\text{Conjugate acid, BH}^+]}{[\text{Base, B}]}$$

pH of the buffer solution is not affected by dilution because ratio under the logarithmic term remains unchanged.

6.13 SOLUBILITY EQUILIBRIA OF SPARINGLY SOLUBLE SALTS

We have already known that the solubility of ionic solids in water varies a great deal. Some of these (like calcium chloride) are so soluble that they are hygroscopic in nature and even absorb water vapour from atmosphere. Others (such as lithium fluoride) have so little solubility that they are commonly termed as insoluble. The solubility depends on a number of factors important amongst which are the lattice enthalpy of the salt and the solvation enthalpy of the ions in a solution. For a salt to dissolve in a solvent the strong forces of attraction between its ions (lattice enthalpy) must be overcome by the ion-solvent interactions. The solvation enthalpy of ions is referred to in terms of solvation which is always negative i.e. energy is released in the process of solvation. The amount of solvation enthalpy depends on the nature of the solvent. In case of a non-polar (covalent) solvent, solvation enthalpy is small and hence, not sufficient to overcome lattice enthalpy of the salt. Consequently, the salt does not dissolve in non-polar solvent. As a general rule, for a salt to be able to dissolve in a particular solvent its solvation enthalpy must be greater than its lattice enthalpy so that the latter may be overcome by former. Each salt has its characteristic solubility which depends on temperature. We classify salts on the basis of their solubility in the following three categories.

Category I	Soluble	Solubility > 0.1M
Category II	Slightly Soluble	0.01M < Solubility < 0.1M
Category III	Sparingly Soluble	Solubility < 0.01M

We shall now consider the equilibrium between the sparingly soluble ionic salt and its saturated aqueous solution.

6.13.1 Solubility Product Constant

Let us now have a solid like barium sulphate in contact with its saturated aqueous solution. The equilibrium between the undissolved solid and the ions in a saturated solution can be represented by the equation:

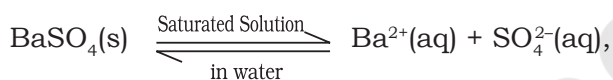

The equilibrium constant is given by the equation:

$$K = \frac{[\text{Ba}^{2+}][\text{SO}_4^{2-}]}{[\text{BaSO}_4]}$$

For a pure solid substance the concentration remains constant and we can write

$$K_{\text{sp}} = K[\text{BaSO}_4] = [\text{Ba}^{2+}][\text{SO}_4^{2-}] \quad (6.43)$$

We call K_{sp} the *solubility product constant* or simply *solubility product*. The experimental value of K_{sp} in above equation at 298K is 1.1×10^{-10} . This means that for solid barium sulphate in equilibrium with its saturated solution, the product of the concentrations of barium and sulphate ions is equal to its solubility product constant. The concentrations of the two ions will be equal to the molar solubility of the barium sulphate. If molar solubility is S, then

$$1.1 \times 10^{-10} = (\text{S})(\text{S}) = \text{S}^2$$

or

$$\text{S} = 1.05 \times 10^{-5}.$$

Thus, molar solubility of barium sulphate will be equal to $1.05 \times 10^{-5} \text{ mol L}^{-1}$.

A salt may give on dissociation two or more than two anions and cations carrying different charges. For example, consider a salt like *zirconium phosphate* of molecular formula $(\text{Zr}^{4+})_3(\text{PO}_4^{3-})_4$. It dissociates into 3 zirconium cations of charge +4 and 4 phosphate anions of charge -3. If the molar solubility of zirconium phosphate is S, then it can be seen from the stoichiometry of the compound that

$$[\text{Zr}^{4+}] = 3\text{S} \text{ and } [\text{PO}_4^{3-}] = 4\text{S}$$

$$\text{and } K_{\text{sp}} = (3\text{S})^3 (4\text{S})^4 = 6912 (\text{S})^7$$

$$\text{or } \text{S} = \left\{ \frac{K_{\text{sp}}}{(3^3 \times 4^4)} \right\}^{1/7} = \left(\frac{K_{\text{sp}}}{6912} \right)^{1/7}$$

A solid salt of the general formula $M_x^{p+} X_y^{q-}$ with molar solubility S in equilibrium with its saturated solution may be represented by the equation:

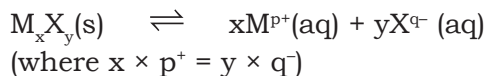

And its solubility product constant is given by:

$$K_{sp} = [M^{p+}]^x [X^{q-}]^y = (xS)^x (yS)^y \quad (6.44)$$

$$= x^x \cdot y^y \cdot S^{(x+y)}$$

$$S^{(x+y)} = K_{sp} / x^x \cdot y^y$$

$$S = (K_{sp} / x^x \cdot y^y)^{1/(x+y)} \quad (6.45)$$

The term K_{sp} in equation is given by Q_{sp} (section 6.6.2) when the concentration of one or more species is not the concentration under equilibrium. Obviously under equilibrium conditions $K_{sp} = Q_{sp}$ but otherwise it gives the direction of the processes of precipitation or dissolution. The solubility product constants of a number of common salts at 298K are given in Table 6.9.

Problem 6.26

Calculate the solubility of A_2X_3 in pure water, assuming that neither kind of ion reacts with water. The solubility product of A_2X_3 , $K_{sp} = 1.1 \times 10^{-23}$.

Solution

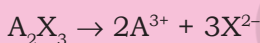

$$K_{sp} = [A^{3+}]^2 [X^{2-}]^3 = 1.1 \times 10^{-23}$$

If S = solubility of A_2X_3 , then

$$[A^{3+}] = 2S; [X^{2-}] = 3S$$

$$\text{therefore, } K_{sp} = (2S)^2 (3S)^3 = 108S^5$$

$$= 1.1 \times 10^{-23}$$

$$\text{thus, } S^5 = 1 \times 10^{-25}$$

$$S = 1.0 \times 10^{-5} \text{ mol/L.}$$

Problem 6.27

The values of K_{sp} of two sparingly soluble salts $Ni(OH)_2$ and $AgCN$ are 2.0×10^{-15} and 6×10^{-17} respectively. Which salt is more soluble? Explain.

Solution

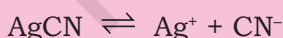
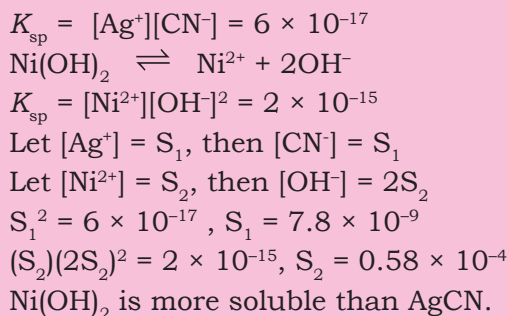

Table 6.9 The Solubility Product Constants, K_{sp} of Some Common Ionic Salts at 298K.

Name of the Salt	Formula	K_{sp}
Silver Bromide	AgBr	5.0×10^{-13}
Silver Carbonate	Ag ₂ CO ₃	8.1×10^{-12}
Silver Chromate	Ag ₂ CrO ₄	1.1×10^{-12}
Silver Chloride	AgCl	1.8×10^{-10}
Silver Iodide	AgI	8.3×10^{-17}
Silver Sulphate	Ag ₂ SO ₄	1.4×10^{-5}
Aluminium Hydroxide	Al(OH) ₃	1.3×10^{-33}
Barium Chromate	BaCrO ₄	1.2×10^{-10}
Barium Fluoride	BaF ₂	1.0×10^{-6}
Barium Sulphate	BaSO ₄	1.1×10^{-10}
Calcium Carbonate	CaCO ₃	2.8×10^{-9}
Calcium Fluoride	CaF ₂	5.3×10^{-9}
Calcium Hydroxide	Ca(OH) ₂	5.5×10^{-6}
Calcium Oxalate	CaC ₂ O ₄	4.0×10^{-9}
Calcium Sulphate	CaSO ₄	9.1×10^{-6}
Cadmium Hydroxide	Cd(OH) ₂	2.5×10^{-14}
Cadmium Sulphide	CdS	8.0×10^{-27}
Chromic Hydroxide	Cr(OH) ₃	6.3×10^{-31}
Cuprous Bromide	CuBr	5.3×10^{-9}
Cupric Carbonate	CuCO ₃	1.4×10^{-10}
Cuprous Chloride	CuCl	1.7×10^{-6}
Cupric Hydroxide	Cu(OH) ₂	2.2×10^{-20}
Cuprous Iodide	CuI	1.1×10^{-12}
Cupric Sulphide	CuS	6.3×10^{-36}
Ferrous Carbonate	FeCO ₃	3.2×10^{-11}
Ferrous Hydroxide	Fe(OH) ₂	8.0×10^{-16}
Ferric Hydroxide	Fe(OH) ₃	1.0×10^{-38}
Ferrous Sulphide	FeS	6.3×10^{-18}
Mercurous Bromide	Hg ₂ Br ₂	5.6×10^{-23}
Mercurous Chloride	Hg ₂ Cl ₂	1.3×10^{-18}
Mercurous Iodide	Hg ₂ I ₂	4.5×10^{-29}
Mercurous Sulphate	Hg ₂ SO ₄	7.4×10^{-7}
Mercuric Sulphide	HgS	4.0×10^{-53}
Magnesium Carbonate	MgCO ₃	3.5×10^{-8}
Magnesium Fluoride	MgF ₂	6.5×10^{-9}
Magnesium Hydroxide	Mg(OH) ₂	1.8×10^{-11}
Magnesium Oxalate	MgC ₂ O ₄	7.0×10^{-7}
Manganese Carbonate	MnCO ₃	1.8×10^{-11}
Manganese Sulphide	MnS	2.5×10^{-13}
Nickel Hydroxide	Ni(OH) ₂	2.0×10^{-15}
Nickel Sulphide	NiS	4.7×10^{-5}
Lead Bromide	PbBr ₂	4.0×10^{-5}
Lead Carbonate	PbCO ₃	7.4×10^{-14}
Lead Chloride	PbCl ₂	1.6×10^{-5}
Lead Fluoride	PbF ₂	7.7×10^{-8}
Lead Hydroxide	Pb(OH) ₂	1.2×10^{-15}
Lead Iodide	PbI ₂	7.1×10^{-9}
Lead Sulphate	PbSO ₄	1.6×10^{-8}
Lead Sulphide	PbS	8.0×10^{-28}
Stannous Hydroxide	Sn(OH) ₂	1.4×10^{-28}
Stannous Sulphide	SnS	1.0×10^{-25}
Strontium Carbonate	SrCO ₃	1.1×10^{-10}
Strontium Fluoride	SrF ₂	2.5×10^{-9}
Strontium Sulphate	SrSO ₄	3.2×10^{-7}
Thallos Bromide	TlBr	3.4×10^{-6}
Thallos Chloride	TlCl	1.7×10^{-4}
Thallos Iodide	TlI	6.5×10^{-8}
Zinc Carbonate	ZnCO ₃	1.4×10^{-11}
Zinc Hydroxide	Zn(OH) ₂	1.0×10^{-15}
Zinc Sulphide	ZnS	1.6×10^{-24}



6.13.2 Common Ion Effect on Solubility of Ionic Salts

It is expected from Le Chatelier's principle that if we increase the concentration of any one of the ions, it should combine with the ion of its opposite charge and some of the salt will be precipitated till once again $K_{sp} = Q_{sp}$. Similarly, if the concentration of one of the ions is decreased, more salt will dissolve to increase the concentration of both the ions till once again $K_{sp} = Q_{sp}$. This is applicable even to soluble salts like sodium chloride except that due to higher concentrations of the ions, we use their activities instead of their molarities in the expression for Q_{sp} . Thus if we take a saturated solution of sodium chloride and pass HCl gas through it, then sodium chloride is precipitated due to increased concentration (activity) of chloride ion available from the dissociation of HCl . Sodium chloride thus obtained is of very high purity and we can get rid of impurities like sodium and magnesium sulphates. The common ion effect is also used for almost complete precipitation of a particular ion as its sparingly soluble salt, with very low value of solubility product for gravimetric estimation. Thus we can precipitate silver ion as silver chloride, ferric ion as its hydroxide (or hydrated ferric oxide) and barium ion as its sulphate for quantitative estimations.

Problem 6.28

Calculate the molar solubility of $\text{Ni}(\text{OH})_2$ in 0.10 M NaOH . The ionic product of $\text{Ni}(\text{OH})_2$ is 2.0×10^{-15} .

Solution

Let the solubility of $\text{Ni}(\text{OH})_2$ be equal to S .

Dissolution of S mol/L of $\text{Ni}(\text{OH})_2$ provides S mol/L of Ni^{2+} and $2S$ mol/L of OH^- , but the total concentration of $\text{OH}^- = (0.10 + 2S)$ mol/L because the solution already contains 0.10 mol/L of OH^- from NaOH .

$$K_{sp} = 2.0 \times 10^{-15} = [\text{Ni}^{2+}][\text{OH}^-]^2$$

$$= (S)(0.10 + 2S)^2$$

As K_{sp} is small, $2S \ll 0.10$,
 thus, $(0.10 + 2S) \approx 0.10$

Hence,

$$2.0 \times 10^{-15} = S(0.10)^2$$

$$S = 2.0 \times 10^{-13} \text{ M} = [\text{Ni}^{2+}]$$

The solubility of salts of weak acids like phosphates increases at lower pH. This is because at lower pH the concentration of the anion decreases due to its protonation. This in turn increases the solubility of the salt so that $K_{sp} = Q_{sp}$. We have to satisfy two equilibria simultaneously i.e.,

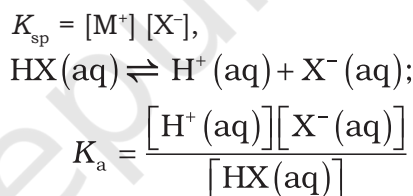

$$[\text{X}^-] / [\text{HX}] = K_a / [\text{H}^+]$$

Taking inverse of both side and adding 1 we get

$$\frac{[\text{HX}]}{[\text{X}^-]} + 1 = \frac{[\text{H}^+]}{K_a} + 1$$

$$\frac{[\text{HX}] + [\text{H}^+]}{[\text{X}^-]} = \frac{[\text{H}^+] + K_a}{K_a}$$

Now, again taking inverse, we get

$[\text{X}^-] / \{[\text{X}^-] + [\text{HX}]\} = f = K_a / (K_a + [\text{H}^+])$ and it can be seen that f decreases as pH decreases. If S is the solubility of the salt at a given pH then

$$K_{sp} = [S][fS] = S^2 \{K_a / (K_a + [\text{H}^+])\} \text{ and}$$

$$S = \{K_{sp} ([\text{H}^+] + K_a) / K_a\}^{1/2} \quad (6.46)$$

Thus solubility S increases with increase in $[\text{H}^+]$ or decrease in pH.

SUMMARY

When the number of molecules leaving the liquid to vapour equals the number of molecules returning to the liquid from vapour, equilibrium is said to be attained and is dynamic in nature. Equilibrium can be established for both physical and chemical processes and at this stage rate of forward and reverse reactions are equal. **Equilibrium constant, K_c** is expressed as the concentration of products divided by reactants, each term raised to the stoichiometric coefficient.

For reaction, $a A + b B \rightleftharpoons c C + d D$

$$K_c = \frac{[C]^c [D]^d}{[A]^a [B]^b}$$

Equilibrium constant has constant value at a fixed temperature and at this stage all the macroscopic properties such as concentration, pressure, etc. become constant. For a gaseous reaction equilibrium constant is expressed as K_p and is written by replacing concentration terms by partial pressures in K_c expression. The direction of reaction can be predicted by reaction quotient Q_c which is equal to K_c at equilibrium. **Le Chatelier's principle** states that the change in any factor such as temperature, pressure, concentration, etc. will cause the equilibrium to shift in such a direction so as to reduce or counteract the effect of the change. It can be used to study the effect of various factors such as temperature, concentration, pressure, catalyst and inert gases on the direction of equilibrium and to control the yield of products by controlling these factors. **Catalyst** does not effect the equilibrium composition of a reaction mixture but increases the rate of chemical reaction by making available a new lower energy pathway for conversion of reactants to products and vice-versa.

All substances that conduct electricity in aqueous solutions are called **electrolytes**. Acids, bases and salts are electrolytes and the conduction of electricity by their aqueous solutions is due to anions and cations produced by the **dissociation or ionization of electrolytes** in aqueous solution. The strong electrolytes are completely dissociated. In weak electrolytes there is equilibrium between the ions and the unionized electrolyte molecules. According to **Arrhenius, acids** give hydrogen ions while bases produce hydroxyl ions in their aqueous solutions. **Brønsted-Lowry** on the other hand, defined an acid as a proton donor and a base as a proton acceptor. When a Brønsted-Lowry acid reacts with a base, it produces its conjugate base and a conjugate acid corresponding to the base with which it reacts. Thus a **conjugate pair of acid-base** differs only by one proton. **Lewis** further generalised the definition of an acid as an electron pair acceptor and a base as an electron pair donor. The expressions for ionization (equilibrium) constants of weak acids (K_a) and weak bases (K_b) are developed using Arrhenius definition. The degree of ionization and its dependence on concentration and common ion are discussed. The **pH scale** ($\text{pH} = -\log[\text{H}^+]$) for the hydrogen ion concentration (activity) has been introduced and extended to other quantities ($\text{pOH} = -\log[\text{OH}^-]$; $\text{p}K_a = -\log[K_a]$; $\text{p}K_b = -\log[K_b]$; and $\text{p}K_w = -\log[K_w]$ etc.). The ionization of water has been considered and we note that the equation: $\text{pH} + \text{pOH} = \text{p}K_w$ is always satisfied. The salts of strong acid and weak base, weak acid and strong base, and weak acid and weak base undergo hydrolysis in aqueous solution. The definition of **buffer solutions**, and their importance are discussed briefly. The solubility equilibrium of sparingly soluble salts is discussed and the equilibrium constant is introduced as **solubility product constant** (K_{sp}). Its relationship with solubility of the salt is established. The conditions of precipitation of the salt from their solutions or their dissolution in water are worked out. The role of common ion and the solubility of sparingly soluble salts is also discussed.

SUGGESTED ACTIVITIES FOR STUDENTS REGARDING THIS UNIT

- The student may use pH paper in determining the pH of fresh juices of various vegetables and fruits, soft drinks, body fluids and also that of water samples available.
- The pH paper may also be used to determine the pH of different salt solutions and from that he/she may determine if these are formed from strong/weak acids and bases.
- They may prepare some buffer solutions by mixing the solutions of sodium acetate and acetic acid and determine their pH using pH paper.
- They may be provided with different indicators to observe their colours in solutions of varying pH.
- They may perform some acid-base titrations using indicators.
- They may observe common ion effect on the solubility of sparingly soluble salts.
- If pH meter is available in their school, they may measure the pH with it and compare the results obtained with that of the pH paper.

EXERCISES

- 6.1 A liquid is in equilibrium with its vapour in a sealed container at a fixed temperature. The volume of the container is suddenly increased.
- What is the initial effect of the change on vapour pressure?
 - How do rates of evaporation and condensation change initially?
 - What happens when equilibrium is restored finally and what will be the final vapour pressure?
- 6.2 What is K_c for the following equilibrium when the equilibrium concentration of each substance is: $[\text{SO}_2] = 0.60\text{M}$, $[\text{O}_2] = 0.82\text{M}$ and $[\text{SO}_3] = 1.90\text{M}$?

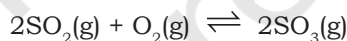

- 6.3 At a certain temperature and total pressure of 10^5Pa , iodine vapour contains 40% by volume of I atoms

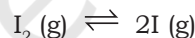

Calculate K_p for the equilibrium.

- 6.4 Write the expression for the equilibrium constant, K_c for each of the following reactions:
- $2\text{NOCl}(\text{g}) \rightleftharpoons 2\text{NO}(\text{g}) + \text{Cl}_2(\text{g})$
 - $2\text{Cu}(\text{NO}_3)_2(\text{s}) \rightleftharpoons 2\text{CuO}(\text{s}) + 4\text{NO}_2(\text{g}) + \text{O}_2(\text{g})$
 - $\text{CH}_3\text{COOC}_2\text{H}_5(\text{aq}) + \text{H}_2\text{O}(\text{l}) \rightleftharpoons \text{CH}_3\text{COOH}(\text{aq}) + \text{C}_2\text{H}_5\text{OH}(\text{aq})$
 - $\text{Fe}^{3+}(\text{aq}) + 3\text{OH}^-(\text{aq}) \rightleftharpoons \text{Fe}(\text{OH})_3(\text{s})$
 - $\text{I}_2(\text{s}) + 5\text{F}_2 \rightleftharpoons 2\text{IF}_5$
- 6.5 Find out the value of K_c for each of the following equilibria from the value of K_p :
- $2\text{NOCl}(\text{g}) \rightleftharpoons 2\text{NO}(\text{g}) + \text{Cl}_2(\text{g}); K_p = 1.8 \times 10^{-2}$ at 500 K
 - $\text{CaCO}_3(\text{s}) \rightleftharpoons \text{CaO}(\text{s}) + \text{CO}_2(\text{g}); K_p = 167$ at 1073 K

- 6.6 For the following equilibrium, $K_c = 6.3 \times 10^{14}$ at 1000 K

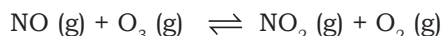

Both the forward and reverse reactions in the equilibrium are elementary bimolecular reactions. What is K_c for the reverse reaction?

- 6.7 Explain why pure liquids and solids can be ignored while writing the equilibrium constant expression?
- 6.8 Reaction between N_2 and O_2 takes place as follows:

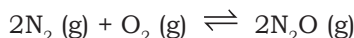

If a mixture of 0.482 mol N_2 and 0.933 mol of O_2 is placed in a 10 L reaction vessel and allowed to form N_2O at a temperature for which $K_c = 2.0 \times 10^{-37}$, determine the composition of equilibrium mixture.

- 6.9 Nitric oxide reacts with Br_2 and gives nitrosyl bromide as per reaction given below:

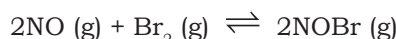

When 0.087 mol of NO and 0.0437 mol of Br_2 are mixed in a closed container at constant temperature, 0.0518 mol of NOBr is obtained at equilibrium. Calculate equilibrium amount of NO and Br_2 .

- 6.10 At 450K, $K_p = 2.0 \times 10^{10}$ /bar for the given reaction at equilibrium.



What is K_c at this temperature ?

- 6.11 A sample of HI(g) is placed in flask at a pressure of 0.2 atm. At equilibrium the partial pressure of HI(g) is 0.04 atm. What is K_p for the given equilibrium ?

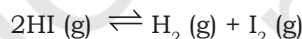

- 6.12 A mixture of 1.57 mol of N_2 , 1.92 mol of H_2 and 8.13 mol of NH_3 is introduced into a 20 L reaction vessel at 500 K. At this temperature, the equilibrium constant, K_c for the reaction $\text{N}_2 \text{ (g)} + 3\text{H}_2 \text{ (g)} \rightleftharpoons 2\text{NH}_3 \text{ (g)}$ is 1.7×10^2 . Is the reaction mixture at equilibrium? If not, what is the direction of the net reaction?

- 6.13 The equilibrium constant expression for a gas reaction is,

$$K_c = \frac{[\text{NH}_3]^4 [\text{O}_2]^5}{[\text{NO}]^4 [\text{H}_2\text{O}]^6}$$

Write the balanced chemical equation corresponding to this expression.

- 6.14 One mole of H_2O and one mole of CO are taken in 10 L vessel and heated to 725 K. At equilibrium 40% of water (by mass) reacts with CO according to the equation,

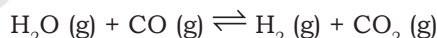

Calculate the equilibrium constant for the reaction.

- 6.15 At 700 K, equilibrium constant for the reaction:

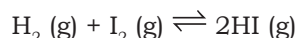

is 54.8. If 0.5 mol L^{-1} of HI(g) is present at equilibrium at 700 K, what are the concentration of H_2 (g) and I_2 (g) assuming that we initially started with HI(g) and allowed it to reach equilibrium at 700K?

- 6.16 What is the equilibrium concentration of each of the substances in the equilibrium when the initial concentration of ICl was 0.78 M ?

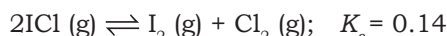

- 6.17 $K_p = 0.04$ atm at 899 K for the equilibrium shown below. What is the equilibrium concentration of C_2H_6 when it is placed in a flask at 4.0 atm pressure and allowed to come to equilibrium?



- 6.18 Ethyl acetate is formed by the reaction between ethanol and acetic acid and the equilibrium is represented as:

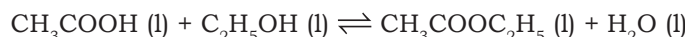

- Write the concentration ratio (reaction quotient), Q_c , for this reaction (note: water is not in excess and is not a solvent in this reaction)
 - At 293 K, if one starts with 1.00 mol of acetic acid and 0.18 mol of ethanol, there is 0.171 mol of ethyl acetate in the final equilibrium mixture. Calculate the equilibrium constant.
 - Starting with 0.5 mol of ethanol and 1.0 mol of acetic acid and maintaining it at 293 K, 0.214 mol of ethyl acetate is found after sometime. Has equilibrium been reached?
- 6.19 A sample of pure PCl_5 was introduced into an evacuated vessel at 473 K. After equilibrium was attained, concentration of PCl_5 was found to be $0.5 \times 10^{-1} \text{ mol L}^{-1}$. If value of K_c is 8.3×10^{-3} , what are the concentrations of PCl_3 and Cl_2 at equilibrium?



- 6.20 One of the reaction that takes place in producing steel from iron ore is the reduction of iron(II) oxide by carbon monoxide to give iron metal and CO_2 .



What are the equilibrium partial pressures of CO and CO_2 at 1050 K if the initial partial pressures are: $p_{\text{CO}} = 1.4$ atm and $p_{\text{CO}_2} = 0.80$ atm?

- 6.21 Equilibrium constant, K_c for the reaction



At a particular time, the analysis shows that composition of the reaction mixture is $3.0 \text{ mol L}^{-1} \text{ N}_2$, $2.0 \text{ mol L}^{-1} \text{ H}_2$ and $0.5 \text{ mol L}^{-1} \text{ NH}_3$. Is the reaction at equilibrium? If not in which direction does the reaction tend to proceed to reach equilibrium?

- 6.22 Bromine monochloride, BrCl decomposes into bromine and chlorine and reaches the equilibrium:



for which $K_c = 32$ at 500 K. If initially pure BrCl is present at a concentration of $3.3 \times 10^{-3} \text{ mol L}^{-1}$, what is its molar concentration in the mixture at equilibrium?

- 6.23 At 1127 K and 1 atm pressure, a gaseous mixture of CO and CO_2 in equilibrium with solid carbon has 90.55% CO by mass

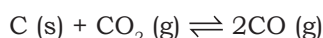

Calculate K_c for this reaction at the above temperature.

- 6.24 Calculate a) ΔG^\ominus and b) the equilibrium constant for the formation of NO_2 from NO and O_2 at 298K

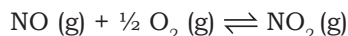

where

$$\Delta_f G^\ominus (\text{NO}_2) = 52.0 \text{ kJ/mol}$$

$$\Delta_f G^\ominus (\text{NO}) = 87.0 \text{ kJ/mol}$$

$$\Delta_f G^\ominus (\text{O}_2) = 0 \text{ kJ/mol}$$

- 6.25 Does the number of moles of reaction products increase, decrease or remain same when each of the following equilibria is subjected to a decrease in pressure by increasing the volume?

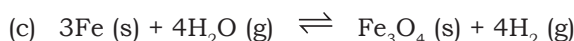
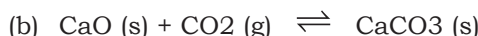
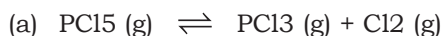

- 6.26 Which of the following reactions will get affected by increasing the pressure? Also, mention whether change will cause the reaction to go into forward or backward direction.

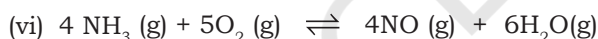
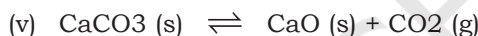
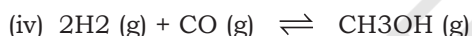
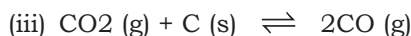
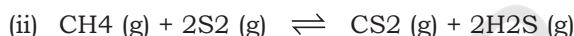
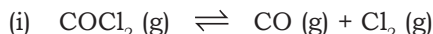

- 6.27 The equilibrium constant for the following reaction is 1.6×10^5 at 1024K

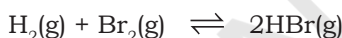

Find the equilibrium pressure of all gases if 10.0 bar of HBr is introduced into a sealed container at 1024K.

- 6.28 Dihydrogen gas is obtained from natural gas by partial oxidation with steam as per following endothermic reaction:

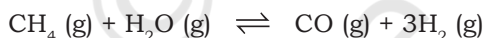

(a) Write an expression for K_p for the above reaction.

(b) How will the values of K_p and composition of equilibrium mixture be affected by

(i) increasing the pressure

(ii) increasing the temperature

(iii) using a catalyst?

- 6.29 Describe the effect of:

a) addition of H_2

b) addition of CH_3OH

c) removal of CO

d) removal of CH_3OH

on the equilibrium of the reaction:

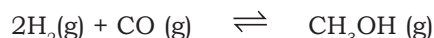

- 6.30 At 473 K, equilibrium constant K_c for decomposition of phosphorus pentachloride, PCl_5 is 8.3×10^{-3} . If decomposition is depicted as,

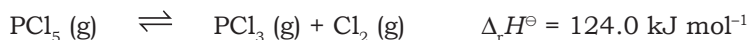

- a) write an expression for K_c for the reaction.
 - b) what is the value of K_c for the reverse reaction at the same temperature?
 - c) what would be the effect on K_c if (i) more PCl_5 is added (ii) pressure is increased (iii) the temperature is increased ?
- 6.31 Dihydrogen gas used in Haber's process is produced by reacting methane from natural gas with high temperature steam. The first stage of two stage reaction involves the formation of CO and H_2 . In second stage, CO formed in first stage is reacted with more steam in water gas shift reaction,
- $$\text{CO}(\text{g}) + \text{H}_2\text{O}(\text{g}) \rightleftharpoons \text{CO}_2(\text{g}) + \text{H}_2(\text{g})$$
- If a reaction vessel at 400°C is charged with an equimolar mixture of CO and steam such that $p_{\text{CO}} = p_{\text{H}_2\text{O}} = 4.0$ bar, what will be the partial pressure of H_2 at equilibrium? $K_p = 10.1$ at 400°C
- 6.32 Predict which of the following reaction will have appreciable concentration of reactants and products:
- a) $\text{Cl}_2(\text{g}) \rightleftharpoons 2\text{Cl}(\text{g})$ $K_c = 5 \times 10^{-39}$
 - b) $\text{Cl}_2(\text{g}) + 2\text{NO}(\text{g}) \rightleftharpoons 2\text{NOCl}(\text{g})$ $K_c = 3.7 \times 10^8$
 - c) $\text{Cl}_2(\text{g}) + 2\text{NO}_2(\text{g}) \rightleftharpoons 2\text{NO}_2\text{Cl}(\text{g})$ $K_c = 1.8$
- 6.33 The value of K_c for the reaction $3\text{O}_2(\text{g}) \rightleftharpoons 2\text{O}_3(\text{g})$ is 2.0×10^{-50} at 25°C . If the equilibrium concentration of O_2 in air at 25°C is 1.6×10^{-2} , what is the concentration of O_3 ?
- 6.34 The reaction, $\text{CO}(\text{g}) + 3\text{H}_2(\text{g}) \rightleftharpoons \text{CH}_4(\text{g}) + \text{H}_2\text{O}(\text{g})$ is at equilibrium at 1300 K in a 1L flask. It also contain 0.30 mol of CO, 0.10 mol of H_2 and 0.02 mol of H_2O and an unknown amount of CH_4 in the flask. Determine the concentration of CH_4 in the mixture. The equilibrium constant, K_c for the reaction at the given temperature is 3.90.
- 6.35 What is meant by the conjugate acid-base pair? Find the conjugate acid/base for the following species:
 HNO_2 , CN^- , HClO_4 , F^- , OH^- , CO_3^{2-} , and S^{2-}
- 6.36 Which of the followings are Lewis acids? H_2O , BF_3 , H^+ , and NH_4^+
- 6.37 What will be the conjugate bases for the Brönsted acids: HF, H_2SO_4 and HCO_3^- ?
- 6.38 Write the conjugate acids for the following Brönsted bases: NH_2^- , NH_3 and HCOO^- .
- 6.39 The species: H_2O , HCO_3^- , HSO_4^- and NH_3 can act both as Brönsted acids and bases. For each case give the corresponding conjugate acid and base.
- 6.40 Classify the following species into Lewis acids and Lewis bases and show how these act as Lewis acid/base: (a) OH^- (b) F^- (c) H^+ (d) BCl_3 .
- 6.41 The concentration of hydrogen ion in a sample of soft drink is 3.8×10^{-3} M. What is its pH?
- 6.42 The pH of a sample of vinegar is 3.76. Calculate the concentration of hydrogen ion in it.
- 6.43 The ionization constant of HF, HCOOH and HCN at 298K are 6.8×10^{-4} , 1.8×10^{-4} and 4.8×10^{-9} respectively. Calculate the ionization constants of the corresponding conjugate base.

- 6.44 The ionization constant of phenol is 1.0×10^{-10} . What is the concentration of phenolate ion in 0.05 M solution of phenol? What will be its degree of ionization if the solution is also 0.01M in sodium phenolate?
- 6.45 The first ionization constant of H_2S is 9.1×10^{-8} . Calculate the concentration of HS^- ion in its 0.1M solution. How will this concentration be affected if the solution is 0.1M in HCl also? If the second dissociation constant of H_2S is 1.2×10^{-13} , calculate the concentration of S^{2-} under both conditions.
- 6.46 The ionization constant of acetic acid is 1.74×10^{-5} . Calculate the degree of dissociation of acetic acid in its 0.05 M solution. Calculate the concentration of acetate ion in the solution and its pH.
- 6.47 It has been found that the pH of a 0.01M solution of an organic acid is 4.15. Calculate the concentration of the anion, the ionization constant of the acid and its $\text{p}K_a$.
- 6.48 Assuming complete dissociation, calculate the pH of the following solutions:
(a) 0.003 M HCl (b) 0.005 M NaOH (c) 0.002 M HBr (d) 0.002 M KOH
- 6.49 Calculate the pH of the following solutions:
a) 2 g of TlOH dissolved in water to give 2 litre of solution.
b) 0.3 g of $\text{Ca}(\text{OH})_2$ dissolved in water to give 500 mL of solution.
c) 0.3 g of NaOH dissolved in water to give 200 mL of solution.
d) 1mL of 13.6 M HCl is diluted with water to give 1 litre of solution.
- 6.50 The degree of ionization of a 0.1M bromoacetic acid solution is 0.132. Calculate the pH of the solution and the $\text{p}K_a$ of bromoacetic acid.
- 6.51 The pH of 0.005M codeine ($\text{C}_{18}\text{H}_{21}\text{NO}_3$) solution is 9.95. Calculate its ionization constant and $\text{p}K_b$.
- 6.52 What is the pH of 0.001M aniline solution? The ionization constant of aniline can be taken from Table 6.7. Calculate the degree of ionization of aniline in the solution. Also calculate the ionization constant of the conjugate acid of aniline.
- 6.53 Calculate the degree of ionization of 0.05M acetic acid if its $\text{p}K_a$ value is 4.74. How is the degree of dissociation affected when its solution also contains (a) 0.01M (b) 0.1M in HCl ?
- 6.54 The ionization constant of dimethylamine is 5.4×10^{-4} . Calculate its degree of ionization in its 0.02M solution. What percentage of dimethylamine is ionized if the solution is also 0.1M in NaOH?
- 6.55 Calculate the hydrogen ion concentration in the following biological fluids whose pH are given below:
(a) Human muscle-fluid, 6.83 (b) Human stomach fluid, 1.2
(c) Human blood, 7.38 (d) Human saliva, 6.4.
- 6.56 The pH of milk, black coffee, tomato juice, lemon juice and egg white are 6.8, 5.0, 4.2, 2.2 and 7.8 respectively. Calculate corresponding hydrogen ion concentration in each.
- 6.57 If 0.561 g of KOH is dissolved in water to give 200 mL of solution at 298 K. Calculate the concentrations of potassium, hydrogen and hydroxyl ions. What is its pH?
- 6.58 The solubility of $\text{Sr}(\text{OH})_2$ at 298 K is 19.23 g/L of solution. Calculate the concentrations of strontium and hydroxyl ions and the pH of the solution.

- 6.59 The ionization constant of propanoic acid is 1.32×10^{-5} . Calculate the degree of ionization of the acid in its 0.05M solution and also its pH. What will be its degree of ionization if the solution is 0.01M in HCl also?
- 6.60 The pH of 0.1M solution of cyanic acid (HCNO) is 2.34. Calculate the ionization constant of the acid and its degree of ionization in the solution.
- 6.61 The ionization constant of nitrous acid is 4.5×10^{-4} . Calculate the pH of 0.04 M sodium nitrite solution and also its degree of hydrolysis.
- 6.62 A 0.02M solution of pyridinium hydrochloride has pH = 3.44. Calculate the ionization constant of pyridine.
- 6.63 Predict if the solutions of the following salts are neutral, acidic or basic:
NaCl, KBr, NaCN, NH_4NO_3 , NaNO_2 and KF
- 6.64 The ionization constant of chloroacetic acid is 1.35×10^{-3} . What will be the pH of 0.1M acid and its 0.1M sodium salt solution?
- 6.65 Ionic product of water at 310 K is 2.7×10^{-14} . What is the pH of neutral water at this temperature?
- 6.66 Calculate the pH of the resultant mixtures:
a) 10 mL of 0.2M Ca(OH)_2 + 25 mL of 0.1M HCl
b) 10 mL of 0.01M H_2SO_4 + 10 mL of 0.01M Ca(OH)_2
c) 10 mL of 0.1M H_2SO_4 + 10 mL of 0.1M KOH
- 6.67 Determine the solubilities of silver chromate, barium chromate, ferric hydroxide, lead chloride and mercurous iodide at 298K from their solubility product constants given in Table 6.9. Determine also the molarities of individual ions.
- 6.68 The solubility product constant of Ag_2CrO_4 and AgBr are 1.1×10^{-12} and 5.0×10^{-13} respectively. Calculate the ratio of the molarities of their saturated solutions.
- 6.69 Equal volumes of 0.002 M solutions of sodium iodate and cupric chlorate are mixed together. Will it lead to precipitation of copper iodate? (For cupric iodate $K_{\text{sp}} = 7.4 \times 10^{-8}$).
- 6.70 The ionization constant of benzoic acid is 6.46×10^{-5} and K_{sp} for silver benzoate is 2.5×10^{-13} . How many times is silver benzoate more soluble in a buffer of pH 3.19 compared to its solubility in pure water?
- 6.71 What is the maximum concentration of equimolar solutions of ferrous sulphate and sodium sulphide so that when mixed in equal volumes, there is no precipitation of iron sulphide? (For iron sulphide, $K_{\text{sp}} = 6.3 \times 10^{-18}$).
- 6.72 What is the minimum volume of water required to dissolve 1g of calcium sulphate at 298 K? (For calcium sulphate, K_{sp} is 9.1×10^{-6}).
- 6.73 The concentration of sulphide ion in 0.1M HCl solution saturated with hydrogen sulphide is 1.0×10^{-19} M. If 10 mL of this is added to 5 mL of 0.04 M solution of the following: FeSO_4 , MnCl_2 , ZnCl_2 and CdCl_2 . in which of these solutions precipitation will take place?

Definitions of the SI Base Units

Metre (m): The metre, symbol m, is the SI unit of length. It is defined by taking the fixed numerical value of the speed of light in vacuum c to be 299792458 when expressed in the unit ms^{-1} , where the second is defined in terms of the caesium frequency.

Kilogram (kg): The kilogram, symbol kg, is the SI unit of mass. It is defined by taking the fixed numerical value of the planck constant h to be $6.62607015 \times 10^{-34}$ when expressed in the unit Js, which is equal to $\text{kgm}^2\text{s}^{-1}$, where the metre and the second are defined in terms of c and ΔV_{Cs} .

Second (s): The symbol s, is the SI unit of time. It is defined by taking the fixed numerical value of the caesium frequency ΔV_{Cs} , the unperturbed ground-state hyperfine transition frequency of the caesium-133 atom, to be 9192631770 when expressed in the unit Hz, which is equal to s^{-1} .

Ampere (A): The ampere, symbol A, is the SI unit of electric current. It is defined by taking the fixed numerical value of the elementary charge e to be $1.602176634 \times 10^{-19}$ when expressed in the unit $\underline{\text{C}}$, which is equal to A s, where the second is defined in terms of.

Kelvin (K): The Kelvin, symbol K, is the SI unit of thermodynamic temperature. It is defined by taking the fixed numerical value of the Boltzmann constant K to be 1.380649×10^{-23} when expressed in the unit JK^{-1} , which is equal to $\text{kgm}^2\text{s}^{-2}\text{K}^{-1}$, where the kilogram, metre and second are defined in terms of h , c and ΔV_{Cs} .

Mole (mol): The mole, symbol mol, is the SI unit of amount of substance. One mole contains exactly $6.02214076 \times 10^{23}$ elementary entities. This number is the fixed numerical value of the Avogadro constant, N_{A} , when expressed in the unit mol^{-1} and is called the Avogadro number. The amount of substance, symbol n , of a system is a measure of the number of specified elementary entities. An elementary entity may be an atom, a molecule, an ion, an electron, any other particle or specified group of particles.

Candela (cd): The candela, symbol cd is the SI unit of luminous intensity in a given direction. It is defined by taking the fixed numerical value of the luminous efficacy of monochromatic radiation of frequency 540×10^{12} Hz, K_{cd} , to be 683 when expressed in the unit $\text{lm}\cdot\text{W}^{-1}$, which is equal to $\text{cd}\cdot\text{sr}\cdot\text{W}^{-1}$, or $\text{cd sr kg}^{-1}\text{m}^{-2}\text{s}^3$, where the kilogram, metre and second are defined in terms of h , c and ΔV_{Cs} .

(The symbols listed here are internationally agreed and should not be changed in other languages and scripts.)

Appendix II

Elements, their Atomic Number and Molar Mass

Element	Symbol	Atomic Number	Molar mass/ (g mol ⁻¹)
Actinium	Ac	89	227.03
Aluminium	Al	13	26.98
Americium	Am	95	(243)
Antimony	Sb	51	121.75
Argon	Ar	18	39.95
Arsenic	As	33	74.92
Astatine	At	85	210
Barium	Ba	56	137.34
Berkelium	Bk	97	(247)
Beryllium	Be	4	9.01
Bismuth	Bi	83	208.98
Bohrium	Bh	107	(264)
Boron	B	5	10.81
Bromine	Br	35	79.91
Cadmium	Cd	48	112.40
Caesium	Cs	55	132.91
Calcium	Ca	20	40.08
Californium	Cf	98	251.08
Carbon	C	6	12.01
Cerium	Ce	58	140.12
Chlorine	Cl	17	35.45
Chromium	Cr	24	52.00
Cobalt	Co	27	58.93
Copper	Cu	29	63.54
Curium	Cm	96	247.07
Dubnium	Db	105	(263)
Dysprosium	Dy	66	162.50
Einsteinium	Es	99	(252)
Erbium	Er	68	167.26
Europium	Eu	63	151.96
Fermium	Fm	100	(257.10)
Fluorine	F	9	19.00
Francium	Fr	87	(223)
Gadolinium	Gd	64	157.25
Gallium	Ga	31	69.72
Germanium	Ge	32	72.61
Gold	Au	79	196.97
Hafnium	Hf	72	178.49
Hassium	Hs	108	(269)
Helium	He	2	4.00
Holmium	Ho	67	164.93
Hydrogen	H	1	1.0079
Indium	In	49	114.82
Iodine	I	53	126.90
Iridium	Ir	77	192.22
Iron	Fe	26	55.85
Krypton	Kr	36	83.80
Lanthanum	La	57	138.91
Lawrencium	Lr	103	(262.1)
Lead	Pb	82	207.19
Lithium	Li	3	6.94
Lutetium	Lu	71	174.96
Magnesium	Mg	12	24.31
Manganese	Mn	25	54.94
Meitneium	Mt	109	(268)
Mendelevium	Md	101	258.10

Element	Symbol	Atomic Number	Molar mass/ (g mol ⁻¹)
Mercury	Hg	80	200.59
Molybdenum	Mo	42	95.94
Neodymium	Nd	60	144.24
Neon	Ne	10	20.18
Neptunium	Np	93	(237.05)
Nickel	Ni	28	58.71
Niobium	Nb	41	92.91
Nitrogen	N	7	14.0067
Nobelium	No	102	(259)
Osmium	Os	76	190.2
Oxygen	O	8	16.00
Palladium	Pd	46	106.4
Phosphorus	P	15	30.97
Platinum	Pt	78	195.09
Plutonium	Pu	94	(244)
Polonium	Po	84	210
Potassium	K	19	39.10
Praseodymium	Pr	59	140.91
Promethium	Pm	61	(145)
Protactinium	Pa	91	231.04
Radium	Ra	88	(226)
Radon	Rn	86	(222)
Rhenium	Re	75	186.2
Rhodium	Rh	45	102.91
Rubidium	Rb	37	85.47
Ruthenium	Ru	44	101.07
Rutherfordium	Rf	104	(261)
Samarium	Sm	62	150.35
Scandium	Sc	21	44.96
Seaborgium	Sg	106	(266)
Selenium	Se	34	78.96
Silicon	Si	14	28.08
Silver	Ag	47	107.87
Sodium	Na	11	22.99
Strontium	Sr	38	87.62
Sulphur	S	16	32.06
Tantalum	Ta	73	180.95
Technetium	Tc	43	(98.91)
Tellurium	Te	52	127.60
Terbium	Tb	65	158.92
Thallium	Tl	81	204.37
Thorium	Th	90	232.04
Thulium	Tm	69	168.93
Tin	Sn	50	118.69
Titanium	Ti	22	47.88
Tungsten	W	74	183.85
Ununbium	Uub	112	(277)
Ununnilium	Uun	110	(269)
Unununium	Uuu	111	(272)
Uranium	U	92	238.03
Vanadium	V	23	50.94
Xenon	Xe	54	131.30
Ytterbium	Yb	70	173.04
Yttrium	Y	39	88.91
Zinc	Zn	30	65.37
Zirconium	Zr	40	91.22

The value given in parenthesis is the molar mass of the isotope of largest known half-life.

Appendix III

A. Specific and Molar Heat Capacities for Some Substances at 298 K and one Atmospheric Pressure		
Substance	Specific Heat Capacity (J/g)	Molar Heat Capacity (J/mol)
air	0.720	20.8
water (liquid)	4.184	75.4
ammonia (gas)	2.06	35.1
hydrogen chloride	0.797	29.1
hydrogen bromide	0.360	29.1
ammonia (liquid)	4.70	79.9
ethyl alcohol (liquid)	2.46	113.16
ethylene glycol (liquid)	2.42	152.52
water (solid)	2.06	37.08
carbon tetrachloride (liquid)	0.861	132.59
chlorofluorocarbon (CCl ₂ F ₂)	0.5980	72.35
ozone	0.817	39.2
neon	1.03	20.7
chlorine	0.477	33.8
bromine	0.473	75.6
iron	0.460	25.1
copper	0.385	24.7
aluminium	0.902	24.35
gold	0.128	25.2
graphite	0.720	8.65

B. Molar Heat Capacities for Some Gases (J/mol)				
Gas	C_p	C_v	C_p - C_v	C_p / C_v
Monatomic*				
helium	20.9	12.8	8.28	1.63
argon	20.8	12.5	8.33	1.66
iodine	20.9	12.6	8.37	1.66
mercury	20.8	12.5	8.33	1.66
Diatomic†				
hydrogen	28.6	20.2	8.33	1.41
oxygen	29.1	20.8	8.33	1.39
nitrogen	29.0	20.7	8.30	1.40
hydrogen chloride	29.6	21.0	8.60	1.39
carbon monoxide	29.0	21.0	8.00	1.41
Triatomic†				
nitrous oxide	39.0	30.5	8.50	1.28
carbon dioxide	37.5	29.0	8.50	1.29
Polyatomic†				
ethane	53.2	44.6	8.60	1.19

*Translational kinetic energy only.
†Translational, vibrational and rotational energy.

Appendix IV

Physical Constants

Quantity	Symbol	Traditional Units	SI Units
Acceleration of gravity	g	980.6 cm/s	9.806 m/s
Atomic mass unit (1/12 the mass of ^{12}C atom)	amu or u	1.6606×10^{-24} g	1.6606×10^{-27} kg
Avogadro constant	N_A	6.022×10^{23} particles/mol	6.022×10^{23} particles/mol
Bohr radius	a_0	0.52918 Å 5.2918×10^{-9} cm	5.2918×10^{-11} m
Boltzmann constant	k	1.3807×10^{-16} erg/K	1.3807×10^{-23} J/K
Charge-to-mass ratio of electron	e/m	1.758820×10^8 coulomb/g	1.7588×10^{11} C/kg
Electronic charge	e	1.602176×10^{-19} coulomb 4.8033×10^{-19} esu	1.60219×10^{-19} C
Electron rest mass	m_e	9.109382×10^{-28} g 0.00054859 u	9.10952×10^{-31} kg
Faraday constant	F	96,487 coulombs/eq 23.06 kcal/volt. eq	96,487 C/mol e^- 96,487 J/V.mol e^-
Gas constant	R	0.8206 $\frac{\text{L atm}}{\text{mol K}}$ 1.987 $\frac{\text{cal}}{\text{mol K}}$	8.3145 $\frac{\text{kPa dm}^3}{\text{mol K}}$ 8.3145 J/mol.K
Molar volume (STP)	V_m	22.710981 L/mol	22.710981×10^{-3} m ³ /mol 22.710981 dm ³ /mol
Neutron rest mass	m_n	1.674927×10^{-24} g 1.008665 u	1.67495×10^{-27} kg
Planck constant	h	6.6262×10^{-27} ergs	6.6262×10^{-34} J s
Proton rest mass	m_p	$1.6726216 \times 10^{-24}$ g 1.007277 u	1.6726×10^{-27} kg
Rydberg constant	R_∞	3.289×10^{15} cycles/s 2.1799×10^{-11} erg	1.0974×10^7 m ⁻¹ 2.1799×10^{-18} J
Speed of light (in a vacuum)	c	2.9979×10^{10} cm/s (186,281 miles/second)	2.9979×10^8 m/s

$$\pi = 3.1416$$

$$e = 2.71828$$

$$\ln X = 2.303 \log X$$

$$2.303 R = 4.576 \text{ cal/mol K} = 19.15 \text{ J/mol K}$$

$$2.303 RT \text{ (at } 25^\circ\text{C)} = 1364 \text{ cal/mol} = 5709 \text{ J/mol}$$

Some Useful Conversion Factors

Common Unit of Mass and Weight

1 pound = 453.59 grams

1 pound = 453.59 grams = 0.45359 kilogram

1 kilogram = 1000 grams = 2.205 pounds

1 gram = 10 decigrams = 100 centigrams
= 1000 milligrams

1 gram = 6.022×10^{23} atomic mass units or u

1 atomic mass unit = 1.6606×10^{-24} gram

1 metric tonne = 1000 kilograms
= 2205 pounds

Common Unit of Volume

1 quart = 0.9463 litre

1 litre = 1.056 quarts

1 litre = 1 cubic decimetre = 1000 cubic

centimetres = 0.001 cubic metre

1 millilitre = 1 cubic centimetre = 0.001 litre
= 1.056×10^{-3} quart

1 cubic foot = 28.316 litres = 29.902 quarts
= 7.475 gallons

Common Units of Energy

1 joule = 1×10^7 ergs

1 thermochemical calorie**

= 4.184 joules

= 4.184×10^7 ergs

= 4.129×10^{-2} litre-atmospheres

= 2.612×10^{19} electron volts

1 ergs = 1×10^{-7} joule = 2.3901×10^{-8} calorie

1 electron volt = 1.6022×10^{-19} joule

= 1.6022×10^{-12} erg

= 96.487 kJ/mol†

1 litre-atmosphere = 24.217 calories

= 101.32 joules

= 1.0132×10^9 ergs

1 British thermal unit = 1055.06 joules

= 1.05506×10^{10} ergs

= 252.2 calories

Common Units of Length

1 inch = 2.54 centimetres (exactly)

1 mile = 5280 feet = 1.609 kilometres

1 yard = 36 inches = 0.9144 metre

1 metre = 100 centimetres = 39.37 inches
= 3.281 feet

= 1.094 yards

1 kilometre = 1000 metres = 1094 yards

= 0.6215 mile

1 Angstrom = 1.0×10^{-8} centimetre

= 0.10 nanometre

= 1.0×10^{-10} metre

= 3.937×10^{-9} inch

Common Units of Force* and Pressure

1 atmosphere = 760 millimetres of mercury

= 1.013×10^5 pascals

= 14.70 pounds per square inch

1 bar = 10^5 pascals

1 torr = 1 millimetre of mercury

1 pascal = $1 \text{ kg/ms}^2 = 1 \text{ N/m}^2$

Temperature

SI Base Unit: Kelvin (K)

K = -273.15°C

K = $^\circ\text{C} + 273.15$

$^\circ\text{F} = 1.8(^\circ\text{C}) + 32$

$$^\circ\text{C} = \frac{^\circ\text{F} - 32}{1.8}$$

* Force: 1 newton (N) = 1 kg m/s^2 , i.e., the force that, when applied for 1 second, gives a 1-kilogram mass a velocity of 1 metre per second.

** The amount of heat required to raise the temperature of one gram of water from 14.5°C to 15.5°C .

† Note that the other units are per particle and must be multiplied by 6.022×10^{23} to be strictly comparable.

Appendix VI

Thermodynamic Data at 298 K

INORGANIC SUBSTANCES

Substance	Enthalpy of formation, $\Delta_f H^\ominus / (\text{kJ mol}^{-1})$	Gibbs Energy of formation, $\Delta_f G^\ominus / (\text{kJ mol}^{-1})$	Entropy,* $S^\ominus / (\text{J K}^{-1} \text{mol}^{-1})$
<i>Aluminium</i>			
Al(s)	0	0	28.33
Al ³⁺ (aq)	-524.7	-481.2	-321.7
Al ₂ O ₃ (s)	-1675.7	-1582.3	50.92
Al(OH) ₃ (s)	-1276	—	—
AlCl ₃ (s)	-704.2	-628.8	110.67
<i>Antimony</i>			
SbH ₃ (g)	145.11	147.75	232.78
SbCl ₃ (g)	-313.8	-301.2	337.80
SbCl ₅ (g)	-394.34	-334.29	401.94
<i>Arsenic</i>			
As(s), gray	0	0	35.1
As ₂ S ₃ (s)	-169.0	-168.6	163.6
AsO ₄ ³⁻ (aq)	-888.14	-648.41	-162.8
<i>Barium</i>			
Ba(s)	0	0	62.8
Ba ²⁺ (aq)	-537.64	-560.77	9.6
BaO(s)	-553.5	-525.1	70.42
BaCO ₃ (s)	-1216.3	-1137.6	112.1
BaCO ₃ (aq)	-1214.78	-1088.59	-47.3
<i>Boron</i>			
B(s)	0	0	5.86
B ₂ O ₃ (s)	-1272.8	-1193.7	53.97
BF ₃ (g)	-1137.0	-1120.3	254.12
<i>Bromine</i>			
Br ₂ (l)	0	0	152.23
Br ₂ (g)	30.91	3.11	245.46
Br(g)	111.88	82.40	175.02
Br ⁻ (aq)	-121.55	-103.96	82.4
HBr(g)	-36.40	-53.45	198.70
BrF ₃ (g)	-255.60	-229.43	292.53
<i>Calcium</i>			
Ca(s)	0	0	41.42
Ca(g)	178.2	144.3	154.88
Ca ²⁺ (aq)	-542.83	-553.58	-53.1

(continued)

Substance	Enthalpy of formation, $\Delta_f H^\ominus / (\text{kJ mol}^{-1})$	Gibbs Energy of formation, $\Delta_f G^\ominus / (\text{kJ mol}^{-1})$	Entropy,* $S^\ominus / (\text{J K}^{-1} \text{mol}^{-1})$
<i>Calcium (continued)</i>			
CaO(s)	-635.09	-604.03	39.75
Ca(OH) ₂ (s)	-986.09	-898.49	83.39
Ca(OH) ₂ (aq)	-1002.82	-868.07	-74.5
CaCO ₃ (s), calcite	-1206.92	-1128.8	92.9
CaCO ₃ (s), aragonite	-1207.1	-1127.8	88.7
CaCO ₃ (aq)	-1219.97	-1081.39	-110.0
CaF ₂ (s)	-1219.6	-1167.3	68.87
CaF ₂ (aq)	-1208.09	-1111.15	-80.8
CaCl ₂ (s)	-795.8	-748.1	104.6
CaCl ₂ (aq)	-877.1	-816.0	59.8
CaBr ₂ (s)	-682.8	-663.6	130
CaC ₂ (s)	-59.8	-64.9	69.96
CaS(s)	-482.4	-477.4	56.5
CaSO ₄ (s)	-1434.11	-1321.79	106.7
CaSO ₄ (aq)	-1452.10	-1298.10	-33.1
<i>Carbon**</i>			
C(s), graphite	0	0	5.740
C(s), diamond	1.895	2.900	2.377
C(g)	716.68	671.26	158.10
CO(g)	-110.53	-137.17	197.67
CO ₂ (g)	-393.51	-394.36	213.74
CO ₃ ²⁻ (aq)	-677.14	-527.81	-56.9
CCl ₄ (l)	-135.44	-65.21	216.40
CS ₂ (l)	89.70	65.27	151.34
HCN(g)	135.1	124.7	201.78
HCN(l)	108.87	124.97	112.84
<i>Cerium</i>			
Ce(s)	0	0	72.0
Ce ³⁺ (aq)	-696.2	-672.0	-205
Ce ⁴⁺ (aq)	-537.2	-503.8	-301
<i>Chlorine</i>			
Cl ₂ (g)	0	0	223.07
Cl(g)	121.68	105.68	165.20
Cl ⁻ (aq)	-167.16	-131.23	56.5
HCl(g)	-92.31	-95.30	186.91
HCl(aq)	-167.16	-131.23	56.5
<i>Copper</i>			
Cu(s)	0	0	33.15
Cu ⁺ (aq)	71.67	49.98	40.6
Cu ²⁺ (aq)	64.77	65.49	-99.6
Cu ₂ O(aq)	-168.6	-146.0	93.14
CuO(s)	-157.3	-129.7	42.63
CuSO ₄ (s)	-771.36	-661.8	109
CuSO ₄ ·5H ₂ O(s)	-2279.7	-1879.7	300.4

** For organic compounds, a separate table is provided in continuation.

(continued)

Substance	Enthalpy of formation, $\Delta_f H^\ominus / (\text{kJ mol}^{-1})$	Gibbs Energy of formation, $\Delta_f G^\ominus / (\text{kJ mol}^{-1})$	Entropy,* $S^\ominus / (\text{J K}^{-1} \text{mol}^{-1})$
<i>Deuterium</i>			
D ₂ (g)	0	0	144.96
D ₂ O(g)	-249.20	-234.54	198.34
D ₂ O(l)	-294.60	-243.44	75.94
<i>Fluorine</i>			
F ₂ (g)	0	0	202.78
F ⁻ (aq)	-332.63	-278.79	-13.8
HF(g)	-271.1	-273.2	173.78
HF(aq)	-332.63	-278.79	-13.8
<i>Hydrogen (see also Deuterium)</i>			
H ₂ (g)	0	0	130.68
H(g)	217.97	203.25	114.71
H ⁺ (aq)	0	0	0
H ₂ O(l)	-285.83	-237.13	69.91
H ₂ O(g)	-241.82	-228.57	188.83
H ₂ O ₂ (l)	-187.78	-120.35	109.6
H ₂ O ₂ (aq)	-191.17	-134.03	143.9
<i>Iodine</i>			
I ₂ (s)	0	0	116.14
I ₂ (g)	62.44	19.33	260.69
I ⁻ (aq)	-55.19	-51.57	111.3
HI(g)	26.48	1.70	206.59
<i>Iron</i>			
Fe(s)	0	0	27.28
Fe ²⁺ (aq)	-89.1	-78.90	-137.7
Fe ³⁺ (aq)	-48.5	-4.7	-315.9
Fe ₃ O ₄ (s), magnetite	-1118.4	-1015.4	146.4
Fe ₂ O ₃ (s), haematite	-824.2	-742.2	87.40
FeS(s,α)	-100.0	-100.4	60.29
FeS(aq)	—	6.9	—
FeS ₂ (s)	-178.2	-166.9	52.93
<i>Lead</i>			
Pb(s)	0	0	64.81
Pb ²⁺ (aq)	-1.7	-24.43	10.5
PbO ₂ (s)	-277.4	-217.33	68.6
PbSO ₄ (s)	-919.94	-813.14	148.57
PbBr ₂ (s)	-278.7	-261.92	161.5
PbBr ₂ (aq)	-244.8	-232.34	175.3
<i>Magnesium</i>			
Mg(s)	0	0	32.68
Mg(g)	147.70	113.10	148.65
Mg ²⁺ (aq)	-466.85	-454.8	-138.1
MgO(s)	-601.70	-569.43	26.94
MgCO ₃ (s)	-1095.8	-1012.1	65.7
MgBr ₂ (s)	-524.3	-503.8	117.2

(continued)

Substance	Enthalpy of formation, $\Delta_f H^\ominus / (\text{kJ mol}^{-1})$	Gibbs Energy of formation, $\Delta_f G^\ominus / (\text{kJ mol}^{-1})$	Entropy,* $S^\ominus / (\text{J K}^{-1} \text{mol}^{-1})$
<i>Mercury</i>			
Hg(l)	0	0	76.02
Hg(g)	61.32	31.82	174.96
HgO(s)	-90.83	-58.54	70.29
Hg ₂ Cl ₂ (s)	-265.22	-210.75	192.5
<i>Nitrogen</i>			
N ₂ (g)	0	0	191.61
NO(g)	90.25	86.55	210.76
N ₂ O(g)	82.05	104.20	219.85
NO ₂ (g)	33.18	51.31	240.06
N ₂ O ₄ (g)	9.16	97.89	304.29
HNO ₃ (l)	-174.10	-80.71	155.60
HNO ₃ (aq)	-207.36	-111.25	146.4
NO ₃ ⁻ (aq)	-205.0	-108.74	146.4
NH ₃ (g)	-46.11	-16.45	192.45
NH ₃ (aq)	-80.29	-26.50	111.3
NH ₄ ⁺ (aq)	-132.51	-79.31	113.4
NH ₂ OH(s)	-114.2	—	—
HN ₃ (g)	294.1	328.1	238.97
N ₂ H ₄ (l)	50.63	149.34	121.21
NH ₄ NO ₃ (s)	-365.56	-183.87	151.08
NH ₄ Cl(s)	-314.43	-202.87	94.6
NH ₄ ClO ₄ (s)	-295.31	-88.75	186.2
<i>Oxygen</i>			
O ₂ (g)	0	0	205.14
O ₃ (g)	142.7	163.2	238.93
OH ⁻ (aq)	-229.99	-157.24	-10.75
<i>Phosphorus</i>			
P(s), white	0	0	41.09
P ₄ (g)	58.91	24.44	279.98
PH ₃ (g)	5.4	13.4	210.23
P ₄ O ₁₀ (s)	-2984.0	-2697.0	228.86
H ₃ PO ₃ (aq)	-964.8	—	—
H ₃ PO ₄ (l)	-1266.9	—	—
H ₃ PO ₄ (aq)	-1277.4	-1018.7	—
PCl ₃ (l)	-319.7	-272.3	217.18
PCl ₃ (g)	-287.0	-267.8	311.78
PCl ₅ (g)	-374.9	-305.0	364.6
<i>Potassium</i>			
K(s)	0	0	64.18
K(g)	89.24	60.59	160.34
K ⁺ (aq)	-252.38	-283.27	102.5
KOH(s)	-424.76	-379.08	78.9
KOH(aq)	-482.37	-440.50	91.6
KF(s)	-567.27	-537.75	66.57

(continued)

Substance	Enthalpy of formation, $\Delta_f H^\ominus / (\text{kJ mol}^{-1})$	Gibbs Energy of formation, $\Delta_f G^\ominus / (\text{kJ mol}^{-1})$	Entropy,* $S^\ominus / (\text{J K}^{-1} \text{mol}^{-1})$
<i>Potassium (continued)</i>			
KCl(s)	-436.75	-409.14	82.59
KBr(s)	-393.80	-380.66	95.90
KI(s)	-327.90	-324.89	106.32
KClO ₃ (s)	-397.73	-296.25	143.1
KClO ₄ (s)	-432.75	-303.09	151.0
K ₂ S(s)	-380.7	-364.0	105
K ₂ S(aq)	-471.5	-480.7	190.4
<i>Silicon</i>			
Si(s)	0	0	18.83
SiO ₂ (s,α)	-910.94	-856.64	41.84
<i>Silver</i>			
Ag(s)	0	0	42.55
Ag ⁺ (aq)	105.58	77.11	72.68
Ag ₂ O(s)	-31.05	-11.20	121.3
AgBr(s)	-100.37	-96.90	107.1
AgBr(aq)	-15.98	-26.86	155.2
AgCl(s)	-127.07	-109.79	96.2
AgCl(aq)	-61.58	-54.12	129.3
AgI(s)	-61.84	-66.19	115.5
AgI(aq)	50.38	25.52	184.1
AgNO ₃ (s)	-124.39	-33.41	140.92
<i>Sodium</i>			
Na(s)	0	0	51.21
Na(g)	107.32	76.76	153.71
Na ⁺ (aq)	-240.12	-261.91	59.0
NaOH(s)	-425.61	-379.49	64.46
NaOH(aq)	-470.11	-419.15	48.1
NaCl(s)	-411.15	-384.14	72.13
NaCl(aq)	-407.3	-393.1	115.5
NaBr(s)	-361.06	-348.98	86.82
NaI(s)	-287.78	-286.06	98.53
NaHCO ₃ (s)	-947.7	-851.9	102.1
Na ₂ CO ₃ (s)	-1130.9	-1047.7	136.0
<i>Sulphur</i>			
S(s), rhombic	0	0	31.80
S(s), monoclinic	0.33	0.1	32.6
S ²⁻ (aq)	33.1	85.8	-14.6
SO ₂ (g)	-296.83	-300.19	248.22
SO ₃ (g)	-395.72	-371.06	256.76
H ₂ SO ₄ (l)	-813.99	-690.00	156.90
H ₂ SO ₄ (aq)	-909.27	-744.53	20.1
SO ₄ ²⁻ (aq)	-909.27	-744.53	20.1
H ₂ S(g)	-20.63	-33.56	205.79
H ₂ S(aq)	-39.7	-27.83	121
SF ₆ (g)	-1209	-1105.3	291.82

(continued)

Substance	Enthalpy of formation, $\Delta_f H^\ominus / (\text{kJ mol}^{-1})$	Gibbs Energy of formation, $\Delta_f G^\ominus / (\text{kJ mol}^{-1})$	Entropy,* $S^\ominus / (\text{J K}^{-1} \text{mol}^{-1})$
<i>Tin</i>			
Sn(s), white	0	0	51.55
Sn(s), gray	-2.09	0.13	44.14
SnO(s)	-285.8	-256.9	56.5
SnO ₂ (s)	-580.7	-519.6	52.3
<i>Zinc</i>			
Zn(s)	0	0	41.63
Zn ²⁺ (aq)	-153.89	-147.06	-112.1
ZnO(s)	-348.28	-318.30	43.64
Zn(g)	+130.73	+95.14	160.93

*The entropies of individual ions in solution are determined by setting the entropy of H⁺ in water equal to 0 and then defining the entropies of all other ions relative to this value; hence a negative entropy is one that is lower than the entropy of H⁺ in water.

ORGANIC COMPOUNDS

Substance	Enthalpy of combustion, $\Delta_c H^\ominus / (\text{kJ mol}^{-1})$	Enthalpy of formation, $\Delta_f H^\ominus / (\text{kJ mol}^{-1})$	Gibbs Energy of formation, $\Delta_f G^\ominus / (\text{kJ mol}^{-1})$	Entropy, $S^\ominus / (\text{J K}^{-1} \text{mol}^{-1})$
<i>Hydrocarbons</i>				
CH ₄ (g), methane	-890	-74.81	-50.72	186.26
C ₂ H ₂ (g), ethyne (acetylene)	-1300	226.73	209.20	200.94
C ₂ H ₄ (g), ethene(ethylene)	-1411	52.26	68.15	219.56
C ₂ H ₆ (g), ethane	-1560	-84.68	-32.82	229.60
C ₃ H ₆ (g), propene (propylene)	-2058	20.42	62.78	266.6
C ₃ H ₆ (g), cyclopropane	-2091	53.30	104.45	237.4
C ₃ H ₈ (g), propane	-2220	-103.85	-23.49	270.2
C ₄ H ₁₀ (g), butane	-2878	-126.15	-17.03	310.1
C ₅ H ₁₂ (g), pentane	-3537	-146.44	-8.20	349
C ₆ H ₆ (l), benzene	-3268	49.0	124.3	173.3
C ₆ H ₆ (g)	-3302	—	—	—
C ₇ H ₈ (l), toluene	-3910	12.0	113.8	221.0
C ₇ H ₈ (g)	-3953	—	—	—
C ₆ H ₁₂ (l), cyclohexane	-3920	-156.4	26.7	204.4
C ₆ H ₁₂ (g)	-3953	—	—	—
C ₈ H ₁₈ (l), octane	-5471	-249.9	6.4	358
<i>Alcohols and phenols</i>				
CH ₃ OH(l), methanol	-726	-238.86	-166.27	126.8
CH ₃ OH(g)	-764	-200.66	-161.96	239.81
C ₂ H ₅ OH(l), ethanol	-1368	-277.69	-174.78	160.7
C ₂ H ₅ OH(g)	-1409	-235.10	-168.49	282.70
C ₆ H ₅ OH(s), phenol	-3054	-164.6	-50.42	144.0

(continued)

Substance	Enthalpy of combustion, $\Delta_c H^\ominus / (\text{kJ mol}^{-1})$	Enthalpy of formation, $\Delta_f H^\ominus / (\text{kJ mol}^{-1})$	Gibbs Energy of formation, $\Delta_f G^\ominus / (\text{kJ mol}^{-1})$	Entropy, $S^\ominus / (\text{J K}^{-1} \text{mol}^{-1})$
<i>Carboxylic acid</i>				
HCOOH(l), formic acid	-255	-424.72	-361.35	128.95
CH ₃ COOH(l), acetic acid	-875	-484.5	-389.9	159.8
CH ₃ COOH (aq)	—	-485.76	-396.64	86.6
(COOH) ₂ (s), oxalic acid	-254	-827.2	-697.9	120
C ₆ H ₅ COOH(s), benzoic acid	-3227	-385.1	-245.3	167.6
<i>Aldehydes and ketones</i>				
HCHO(g), methanal (formaldehyde)	-571	-108.57	-102.53	218.77
CH ₃ CHO(l), ethanal (acetaldehyde)	-1166	-192.30	-128.12	160.2
CH ₃ CHO(g)	-1192	-166.19	-128.86	250.3
CH ₃ COCH ₃ (l), propanone (acetone)	-1790	-248.1	-155.4	200
<i>Sugars</i>				
C ₆ H ₁₂ O ₆ (s), glucose	-2808	-1268	-910	212
C ₆ H ₁₂ O ₆ (aq)	—	—	-917	—
C ₆ H ₁₂ O ₆ (s), fructose	-2810	-1266	—	—
C ₁₂ H ₂₂ O ₁₁ (s), sucrose	-5645	-2222	-1545	360
<i>Nitrogen compounds</i>				
CO(NH ₂) ₂ (s), urea	-632	-333.51	-197.33	104.60
C ₆ H ₅ NH ₂ (l), aniline	-3393	31.6	149.1	191.3
NH ₂ CH ₂ COOH(s), glycine	-969	-532.9	-373.4	103.51
CH ₃ NH ₂ (g), methylamine	-1085	-22.97	32.16	243.41

Appendix VII

Standard potentials at 298 K in electrochemical order

Reduction half-reaction	E^\ominus/V	Reduction half-reaction	E^\ominus/V
$\text{H}_4\text{XeO}_6 + 2\text{H}^+ + 2\text{e}^- \longrightarrow \text{XeO}_3 + 3\text{H}_2\text{O}$	+3.0	$\text{Cu}^+ + \text{e}^- \longrightarrow \text{Cu}$	+0.52
$\text{F}_2 + 2\text{e}^- \longrightarrow 2\text{F}^-$	+2.87	$\text{NiOOH} + \text{H}_2\text{O} + \text{e}^- \longrightarrow \text{Ni}(\text{OH})_2 + \text{OH}^-$	+0.49
$\text{O}_3 + 2\text{H}^+ + 2\text{e}^- \longrightarrow \text{O}_2 + \text{H}_2\text{O}$	+2.07	$\text{Ag}_2\text{CrO}_4 + 2\text{e}^- \longrightarrow 2\text{Ag} + \text{CrO}_4^{2-}$	+0.45
$\text{S}_2\text{O}_8^{2-} + 2\text{e}^- \longrightarrow 2\text{SO}_4^{2-}$	+2.05	$\text{O}_2 + 2\text{H}_2\text{O} + 4\text{e}^- \longrightarrow 4\text{OH}^-$	+0.40
$\text{Ag}^+ + \text{e}^- \longrightarrow \text{Ag}^+$	+1.98	$\text{ClO}_4^- + \text{H}_2\text{O} + 2\text{e}^- \longrightarrow \text{ClO}_3^- + 2\text{OH}^-$	+0.36
$\text{Co}^{3+} + \text{e}^- \longrightarrow \text{Co}^{2+}$	+1.81	$[\text{Fe}(\text{CN})_6]^{3-} + \text{e}^- \longrightarrow [\text{Fe}(\text{CN})_6]^{4-}$	+0.36
$\text{H}_2\text{O}_2 + 2\text{H}^+ + 2\text{e}^- \longrightarrow 2\text{H}_2\text{O}$	+1.78	$\text{Cu}^{2+} + 2\text{e}^- \longrightarrow \text{Cu}$	+0.34
$\text{Au}^+ + \text{e}^- \longrightarrow \text{Au}$	+1.69	$\text{Hg}_2\text{Cl}_2 + 2\text{e}^- \longrightarrow 2\text{Hg} + 2\text{Cl}^-$	+0.27
$\text{Pb}^{4+} + 2\text{e}^- \longrightarrow \text{Pb}^{2+}$	+1.67	$\text{AgCl} + \text{e}^- \longrightarrow \text{Ag} + \text{Cl}^-$	+0.27
$2\text{HClO} + 2\text{H}^+ + 2\text{e}^- \longrightarrow \text{Cl}_2 + 2\text{H}_2\text{O}$	+1.63	$\text{Bi}^{3+} + 3\text{e}^- \longrightarrow \text{Bi}$	+0.20
$\text{Ce}^{4+} + \text{e}^- \longrightarrow \text{Ce}^{3+}$	+1.61	$\text{SO}_4^{2-} + 4\text{H}^+ + 2\text{e}^- \longrightarrow \text{H}_2\text{SO}_3 + \text{H}_2\text{O}$	+0.17
$2\text{HBrO} + 2\text{H}^+ + 2\text{e}^- \longrightarrow \text{Br}_2 + 2\text{H}_2\text{O}$	+1.60	$\text{Cu}^{2+} + \text{e}^- \longrightarrow \text{Cu}^+$	+0.16
$\text{MnO}_4^- + 8\text{H}^+ + 5\text{e}^- \longrightarrow \text{Mn}^{2+} + 4\text{H}_2\text{O}$	+1.51	$\text{Sn}^{4+} + 2\text{e}^- \longrightarrow \text{Sn}^{2+}$	+0.15
$\text{Mn}^{3+} + \text{e}^- \longrightarrow \text{Mn}^{2+}$	+1.51	$\text{AgBr} + \text{e}^- \longrightarrow \text{Ag} + \text{Br}^-$	+0.07
$\text{Au}^{3+} + 3\text{e}^- \longrightarrow \text{Au}$	+1.40	$\text{Ti}^{4+} + \text{e}^- \longrightarrow \text{Ti}^{3+}$	0.00
$\text{Cl}_2 + 2\text{e}^- \longrightarrow 2\text{Cl}^-$	+1.36	$2\text{H}^+ + 2\text{e}^- \longrightarrow \text{H}_2$	0.0 by definition
$\text{Cr}_2\text{O}_7^{2-} + 14\text{H}^+ + 6\text{e}^- \longrightarrow 2\text{Cr}^{3+} + 7\text{H}_2\text{O}$	+1.33	$\text{Fe}^{3+} + 3\text{e}^- \longrightarrow \text{Fe}$	-0.04
$\text{O}_3 + \text{H}_2\text{O} + 2\text{e}^- \longrightarrow \text{O}_2 + 2\text{OH}^-$	+1.24	$\text{O}_2 + \text{H}_2\text{O} + 2\text{e}^- \longrightarrow \text{HO}_2^- + \text{OH}^-$	-0.08
$\text{O}_2 + 4\text{H}^+ + 4\text{e}^- \longrightarrow 2\text{H}_2\text{O}$	+1.23	$\text{Pb}^{2+} + 2\text{e}^- \longrightarrow \text{Pb}$	-0.13
$\text{ClO}_4^- + 2\text{H}^+ + 2\text{e}^- \longrightarrow \text{ClO}_3^- + 2\text{H}_2\text{O}$	+1.23	$\text{In}^+ + \text{e}^- \longrightarrow \text{In}$	-0.14
$\text{MnO}_2 + 4\text{H}^+ + 2\text{e}^- \longrightarrow \text{Mn}^{2+} + 2\text{H}_2\text{O}$	+1.23	$\text{Sn}^{2+} + 2\text{e}^- \longrightarrow \text{Sn}$	-0.14
$\text{Pt}^{2+} + 2\text{e}^- \longrightarrow \text{Pt}$	+1.20	$\text{AgI} + \text{e}^- \longrightarrow \text{Ag} + \text{I}^-$	-0.15
$\text{Br}_2 + 2\text{e}^- \longrightarrow 2\text{Br}^-$	+1.09	$\text{Ni}^{2+} + 2\text{e}^- \longrightarrow \text{Ni}$	-0.23
$\text{Pu}^{4+} + \text{e}^- \longrightarrow \text{Pu}^{3+}$	+0.97	$\text{V}^{3+} + \text{e}^- \longrightarrow \text{V}^{2+}$	-0.26
$\text{NO}_3^- + 4\text{H}^+ + 3\text{e}^- \longrightarrow \text{NO} + 2\text{H}_2\text{O}$	+0.96	$\text{Co}^{2+} + 2\text{e}^- \longrightarrow \text{Co}$	-0.28
$2\text{Hg}_2^{2+} + 2\text{e}^- \longrightarrow \text{Hg}_2^{2+}$	+0.92	$\text{In}^{3+} + 3\text{e}^- \longrightarrow \text{In}$	-0.34
$\text{ClO}^- + \text{H}_2\text{O} + 2\text{e}^- \longrightarrow \text{Cl}^- + 2\text{OH}^-$	+0.89	$\text{Tl}^+ + \text{e}^- \longrightarrow \text{Tl}$	-0.34
$\text{Hg}_2^{2+} + 2\text{e}^- \longrightarrow \text{Hg}$	+0.86	$\text{PbSO}_4 + 2\text{e}^- \longrightarrow \text{Pb} + \text{SO}_4^{2-}$	-0.36
$\text{NO}_3^- + 2\text{H}^+ + \text{e}^- \longrightarrow \text{NO}_2 + \text{H}_2\text{O}$	+0.80	$\text{Ti}^{3+} + \text{e}^- \longrightarrow \text{Ti}^{2+}$	-0.37
$\text{Ag}^+ + \text{e}^- \longrightarrow \text{Ag}$	+0.80	$\text{Cd}^{2+} + 2\text{e}^- \longrightarrow \text{Cd}$	-0.40
$\text{Hg}_2^{2+} + 2\text{e}^- \longrightarrow 2\text{Hg}$	+0.79	$\text{In}^{2+} + \text{e}^- \longrightarrow \text{In}^+$	-0.40
$\text{Fe}^{3+} + \text{e}^- \longrightarrow \text{Fe}^{2+}$	+0.77	$\text{Cr}^{3+} + \text{e}^- \longrightarrow \text{Cr}^{2+}$	-0.41
$\text{BrO}^- + \text{H}_2\text{O} + 2\text{e}^- \longrightarrow \text{Br}^- + 2\text{OH}^-$	+0.76	$\text{Fe}^{2+} + 2\text{e}^- \longrightarrow \text{Fe}$	-0.44
$\text{Hg}_2\text{SO}_4 + 2\text{e}^- \longrightarrow 2\text{Hg} + \text{SO}_4^{2-}$	+0.62	$\text{In}^{3+} + 2\text{e}^- \longrightarrow \text{In}^+$	-0.44
$\text{MnO}_4^{2-} + 2\text{H}_2\text{O} + 2\text{e}^- \longrightarrow \text{MnO}_2 + 4\text{OH}^-$	+0.60	$\text{S} + 2\text{e}^- \longrightarrow \text{S}^{2-}$	-0.48
$\text{MnO}_4^- + \text{e}^- \longrightarrow \text{MnO}_4^{2-}$	+0.56	$\text{In}^{3+} + \text{e}^- \longrightarrow \text{In}^{2+}$	-0.49
$\text{I}_2 + 2\text{e}^- \longrightarrow 2\text{I}^-$	+0.54	$\text{U}^{4+} + \text{e}^- \longrightarrow \text{U}^{3+}$	-0.61
$\text{I}_3^- + 2\text{e}^- \longrightarrow 3\text{I}^-$	+0.53	$\text{Cr}^{3+} + 3\text{e}^- \longrightarrow \text{Cr}$	-0.74
		$\text{Zn}^{2+} + 2\text{e}^- \longrightarrow \text{Zn}$	-0.76

(continued)

Appendix continued

Reduction half-reaction	E^\ominus/V	Reduction half-reaction	E^\ominus/V
$\text{Cd}(\text{OH})_2 + 2e^- \longrightarrow \text{Cd} + 2\text{OH}^-$	-0.81	$\text{La}^{3+} + 3e^- \longrightarrow \text{La}$	-2.52
$2\text{H}_2\text{O} + 2e^- \longrightarrow \text{H}_2 + 2\text{OH}^-$	-0.83	$\text{Na}^+ + e^- \longrightarrow \text{Na}$	-2.71
$\text{Cr}^{2+} + 2e^- \longrightarrow \text{Cr}$	-0.91	$\text{Ca}^{2+} + 2e^- \longrightarrow \text{Ca}$	-2.87
$\text{Mn}^{2+} + 2e^- \longrightarrow \text{Mn}$	-1.18	$\text{Sr}^{2+} + 2e^- \longrightarrow \text{Sr}$	-2.89
$\text{V}^{2+} + 2e^- \longrightarrow \text{V}$	-1.19	$\text{Ba}^{2+} + 2e^- \longrightarrow \text{Ba}$	-2.91
$\text{Ti}^{2+} + 2e^- \longrightarrow \text{Ti}$	-1.63	$\text{Ra}^{2+} + 2e^- \longrightarrow \text{Ra}$	-2.92
$\text{Al}^{3+} + 3e^- \longrightarrow \text{Al}$	-1.66	$\text{Cs}^+ + e^- \longrightarrow \text{Cs}$	-2.92
$\text{U}^{3+} + 3e^- \longrightarrow \text{U}$	-1.79	$\text{Rb}^+ + e^- \longrightarrow \text{Rb}$	-2.93
$\text{Sc}^{3+} + 3e^- \longrightarrow \text{Sc}$	-2.09	$\text{K}^+ + e^- \longrightarrow \text{K}$	-2.93
$\text{Mg}^{2+} + 2e^- \longrightarrow \text{Mg}$	-2.36	$\text{Li}^+ + e^- \longrightarrow \text{Li}$	-3.05
$\text{Ce}^{3+} + 3e^- \longrightarrow \text{Ce}$	-2.48		

Answer to Some Selected Problems

UNIT 1

- 1.17 $\sim 15 \times 10^{-4} \text{ g}$, $1.25 \times 10^{-4} \text{ m}$
- 1.18 (i) 4.8×10^{-3} (ii) 2.34×10^5 (iii) 8.008×10^3 (iv) 5.000×10^2
(v) 6.0012
- 1.19 (i) 2 (ii) 3 (iii) 4 (iv) 3
(v) 4 (vi) 5
- 1.20 (i) 34.2 (ii) 10.4 (iii) 0.0460 (iv) 2810
- 1.21 (a) law of multiple proportion (b) (i) Ans : (10^6 mm , 10^{15} pm)
(ii) Ans : (10^{-6} kg , 10^6 ng)
(iii) Ans : (10^{-3} L , 10^{-3} dm^3)
- 1.22 $6.00 \times 10^{-1} \text{ m} = 0.600 \text{ m}$
- 1.23 (i) B is limiting (ii) A is limiting
(iii) Stoichiometric mixture –No (iv) B is limiting
(v) A is limiting
- 1.24 (i) $2.43 \times 10^3 \text{ g}$ (ii) Yes
(iii) Hydrogen will remain unreacted; $5.72 \times 10^2 \text{ g}$
- 1.26 Ten volumes
- 1.27 (i) $2.87 \times 10^{-11} \text{ m}$ (ii) $1.515 \times 10^{-11} \text{ m}$ (iii) $2.5365 \times 10^{-2} \text{ kg}$
- 1.30 $1.99265 \times 10^{-23} \text{ g}$
- 1.31 (i) 3 (ii) 4 (iii) 4
- 1.32 $39.948 \text{ g mol}^{-1}$
- 1.33 (i) 3.131×10^{25} atoms (ii) 13 atoms (iii) 7.8286×10^{24} atoms
- 1.34 Empirical formula CH, molar mass 26.0 g mol^{-1} , molecular formula C_2H_2
- 1.35 0.94 g CaCO_3
- 1.36 8.40 g HCl

UNIT 2

- 2.1 (i) 1.099×10^{27} electrons (ii) $5.48 \times 10^{-7} \text{ kg}$, $9.65 \times 10^4 \text{ C}$
- 2.2 (i) 6.022×10^{24} electrons
(ii) (a) 2.4088×10^{21} neutrons (b) $4.0347 \times 10^{-6} \text{ kg}$
(iii) (a) 1.2044×10^{22} protons (b) $2.015 \times 10^{-5} \text{ kg}$
- 2.3 7,6: 8,8: 12,12: 30,26: 50, 38
- 2.4 (i) Cl (ii) U (iii) Be
- 2.5 $5.17 \times 10^{14} \text{ s}^{-1}$, $1.72 \times 10^6 \text{ m}^{-1}$
- 2.6 (i) $1.988 \times 10^{-18} \text{ J}$ (ii) $3.98 \times 10^{-15} \text{ J}$

- 2.7 $6.0 \times 10^{-2} \text{ m}$, $5.0 \times 10^9 \text{ s}^{-1}$ and 16.66 m^{-1}
- 2.8 2.012×10^{16} photons
- 2.9 (i) $4.97 \times 10^{-19} \text{ J}$ (3.10 eV); (ii) 0.97 eV (iii) $5.84 \times 10^5 \text{ m s}^{-1}$
- 2.10 494 kJ mol^{-1}
- 2.11 $7.18 \times 10^{19} \text{ s}^{-1}$
- 2.12 $4.41 \times 10^{14} \text{ s}^{-1}$, $2.91 \times 10^{-19} \text{ J}$
- 2.13 486 nm
- 2.14 $8.72 \times 10^{-20} \text{ J}$
- 2.15 15 emission lines
- 2.16 (i) $8.72 \times 10^{-20} \text{ J}$ (ii) 1.3225 nm
- 2.17 $1.523 \times 10^6 \text{ m}^{-1}$
- 2.18 $2.08 \times 10^{-11} \text{ ergs}$, 950 Å
- 2.19 3647 Å
- 2.20 $3.55 \times 10^{-11} \text{ m}$
- 2.21 8967 Å
- 2.22 Na^+ , Mg^{2+} , Ca^{2+} ; Ar, S^{2-} and K^+
- 2.23 (i) (a) $1s^2$ (b) $1s^2 2s^2 2p^6$; (c) $1s^2 2s^2 2p^6$ (d) $1s^2 2s^2 2p^6$
- 2.24 $n = 5$
- 2.25 $n = 3$; $l = 2$; $m_l = -2, -1, 0, +1, +2$ (any one value)
- 2.26 (i) 29 protons
- 2.27 1, 2, 15
- 2.28 (i) l m_l
 0 0
 1 -1, 0, +1
 2 -2, -1, 0, +1, +2
- (ii) $l = 2$; $m_l = -2, -1, 0, +1, +2$
- (iii) 2s, 2p
- 2.29 (a) 1s, (b) 3p, (c) 4d and (d) 4f
- 2.30 (a), (c) and (e) are not possible
- 2.31 (a) 16 electrons (b) 2 electrons
- 2.33 $n = 2$ to $n = 1$
- 2.34 $8.72 \times 10^{-18} \text{ J per atom}$
- 2.35 1.33×10^9
- 2.36 0.06 nm
- 2.37 (a) $1.3 \times 10^2 \text{ pm}$ (b) $6.15 \times 10^7 \text{ pm}$
- 2.38 1560
- 2.39 8
- 2.40 More number of K-particles will pass as the nucleus of the lighter atoms is small, smaller number of K-particles will be deflected as a number of positive charges is less than on the lighter nuclei.
- 2.41 For a given element the number of protons is the same for the isotopes, whereas the mass number can be different for the given atomic number.
- 2.42 ${}_{35}^{81}\text{Br}$
- 2.43 ${}_{17}^{37}\text{Cl}^{-1}$

- 2.44 ${}_{26}^{56}\text{Fe}^{3+}$
- 2.45 Cosmic rays > X-rays > amber colour > microwave > FM
- 2.46 $3.3 \times 10^6 \text{ J}$
- 2.47 (a) $4.87 \times 10^{14} \text{ s}^{-1}$ (b) $9.0 \times 10^9 \text{ m}$ (c) $32.27 \times 10^{-20} \text{ J}$
(d) 6.2×10^{18} quanta
- 2.48 10
- 2.49 $8.28 \times 10^{-10} \text{ J}$
- 2.50 $3.45 \times 10^{-22} \text{ J}$
- 2.51 (a) Threshold wave length 652.46 nm (b) Threshold frequency of radiation $4.598 \times 10^{14} \text{ s}^{-1}$
(c) Kinetic energy of ejected photoelectron $9.29 \times 10^{-20} \text{ J}$, Velocity of photoelectron $4.516 \times 10^5 \text{ ms}^{-1}$
- 2.52 530.9 nm
- 2.53 4.48 eV
- 2.54 $7.6 \times 10^3 \text{ eV}$
- 2.55 infrared, 5
- 2.56 434 nm
- 2.57 455 pm
- 2.58 494.5 ms^{-1}
- 2.59 332 pm
- 2.60 $1.516 \times 10^{-38} \text{ m}$
- 2.61 Cannot be defined as the actual magnitude is smaller than uncertainty.
- 2.62 (v) < (ii) = (iv) < (vi) = (iii) < (i)
- 2.63 4p
- 2.64 (i) 2s (ii) 4d (iii) 3p
- 2.65 Si
- 2.66 (a) 3 (b) 2 (c) 6
(d) 4 (e) zero
- 2.67 16

UNIT 5

- 5.1 (ii)
- 5.2 (iii)
- 5.3 (ii)
- 5.4 (iii)
- 5.5 (i)
- 5.6 (iv)
- 5.7 $q = + 701 \text{ J}$
 $w = - 394 \text{ J}$, since work is done by the system
 $\Delta U = 307 \text{ J}$
- 5.8 -743.939 kJ
- 5.9 1.067 kJ
- 5.10 $\Delta H = -7.151 \text{ kJ mol}^{-1}$

- 5.11 -314.8 kJ
 5.12 $\Delta_r H = -778 \text{ kJ}$
 5.13 $-46.2 \text{ kJ mol}^{-1}$
 5.14 -239 kJ mol^{-1}
 5.15 326 kJ mol^{-1}
 5.16 $\Delta S > 0$
 5.17 2000 K
 5.18 ΔH is negative (bond energy is released) and ΔS is negative (There is less randomness among the molecules than among the atoms)
 5.19 0.164 kJ , the reaction is not spontaneous.
 5.20 $-5.744 \text{ kJ mol}^{-1}$
 5.21 NO(g) is unstable, but $\text{NO}_2(\text{g})$ is formed.
 5.22 $q_{\text{surr}} = +286 \text{ kJ mol}^{-1}$
 $\Delta S_{\text{surr}} = 959.73 \text{ J K}^{-1}$

UNIT 6

- 6.2 12.229
 6.3 2.67×10^4
 6.5 (i) 4.33×10^{-4} (ii) 1.90
 6.6 1.59×10^{-15}
 6.8 $[\text{N}_2] = 0.0482 \text{ molL}^{-1}$, $[\text{O}_2] = 0.0933 \text{ molL}^{-1}$, $[\text{N}_2\text{O}] = 6.6 \times 10^{-21} \text{ molL}^{-1}$
 6.9 0.0352 mol of NO and 0.0178 mol of Br_2
 6.10 $7.47 \times 10^{11} \text{ M}^{-1}$
 6.11 4.0
 6.12 $Q_c = 2.379 \times 10^3$. No, reaction is not at equilibrium.
 6.14 0.44
 6.15 0.068 molL^{-1} each of H_2 and I_2
 6.16 $[\text{I}_2] = [\text{Cl}_2] = 0.167 \text{ M}$, $[\text{ICl}] = 0.446 \text{ M}$
 6.17 $[\text{C}_2\text{H}_6]_{\text{eq}} = 3.62 \text{ atm}$
 6.18 (i) $[\text{CH}_3\text{COOC}_2\text{H}_5][\text{H}_2\text{O}] / [\text{CH}_3\text{COOH}][\text{C}_2\text{H}_5\text{OH}]$
 (ii) 3.92 (iii) value of Q_c is less than K_c therefore equilibrium is not attained.
 6.19 0.02 molL^{-1} for both.
 6.20 $[\text{PCO}] = 1.739 \text{ atm}$, $[\text{PCO}_2] = 0.461 \text{ atm}$.
 6.21 No, the reaction proceeds to form more products.
 6.22 $3 \times 10^{-4} \text{ molL}^{-1}$
 6.23 0.149
 6.24 a) -35.0 kJ , b) 1.365×10^6
 6.27 $[\text{P}_{\text{H}_2}]_{\text{eq}} = [\text{P}_{\text{Br}_2}]_{\text{eq}} = 2.5 \times 10^{-2} \text{ bar}$, $[\text{P}_{\text{HBr}}] = 10.0 \text{ bar}$
 6.30 b) 120.48
 6.31 $[\text{H}_2]_{\text{eq}} = 0.96 \text{ bar}$
 6.33 $2.86 \times 10^{-28} \text{ M}$
 6.34 5.85×10^{-2}
 6.35 NO_2^- , HCN , ClO_4^- , HF , H_2O , HCO_3^- , HS^-
 6.36 BF_3 , H^+ , NH_4^+

- 6.37 F^- , HSO_4^- , CO_3^{2-}
- 6.38 NH_3 , NH_4^+ , $HCOOH$
- 6.41 2.42
- 6.42 $1.7 \times 10^{-4}M$
- 6.43 $F^- = 1.5 \times 10^{-11}$, $HCOO^- = 5.6 \times 10^{-11}$, $CN^- = 2.08 \times 10^{-6}$
- 6.44 [phenolate ion] = 2.2×10^{-6} , $\alpha = 4.47 \times 10^{-5}$, α in sodium phenolate = 10^{-8}
- 6.45 $[HS^-] = 9.54 \times 10^{-5}$, in 0.1M HCl $[HS^-] = 9.1 \times 10^{-8}M$, $[S^{2-}] = 1.2 \times 10^{-13}M$, in 0.1M HCl $[S^{2-}] = 1.09 \times 10^{-19}M$
- 6.46 $[Ac^-] = 0.00093$, pH = 3.03
- 6.47 $[A^-] = 7.08 \times 10^{-5}M$, $K_a = 5.08 \times 10^{-7}$, $pK_a = 6.29$
- 6.48 a) 2.52 b) 11.70 c) 2.70 d) 11.30
- 6.49 a) 11.65 b) 12.21 c) 12.57 c) 1.87
- 6.50 pH = 1.88, $pK_a = 2.70$
- 6.51 $K_b = 1.6 \times 10^{-6}$, $pK_b = 5.8$
- 6.52 $\alpha = 6.53 \times 10^{-4}$, $K_a = 2.35 \times 10^{-5}$
- 6.53 a) 0.0018 b) 0.00018
- 6.54 $\alpha = 0.0054$
- 6.55 a) $1.48 \times 10^{-7}M$, b) 0.063 c) $4.17 \times 10^{-8}M$ d) 3.98×10^{-7}
- 6.56 a) $1.5 \times 10^{-7}M$, b) $10^{-5}M$, c) $6.31 \times 10^{-5}M$ d) $6.31 \times 10^{-3}M$
- 6.57 $[K^+] = [OH^-] = 0.05M$, $[H^+] = 2.0 \times 10^{-13}M$
- 6.58 $[Sr^{2+}] = 0.1581M$, $[OH^-] = 0.3162M$, pH = 13.50
- 6.59 $\alpha = 1.63 \times 10^{-2}$, pH = 3.09. In presence of 0.01M HCl, $\alpha = 1.32 \times 10^{-3}$
- 6.60 $K_a = 2.09 \times 10^{-4}$ and degree of ionization = 0.0457
- 6.61 pH = 7.97. Degree of hydrolysis = 2.36×10^{-5}
- 6.62 $K_b = 1.5 \times 10^{-9}$
- 6.63 NaCl, KBr solutions are neutral, NaCN, $NaNO_2$ and KF solutions are basic and NH_4NO_3 solution is acidic.
- 6.64 (a) pH of acid solution = 1.9 (b) pH of its salt solution = 7.9
- 6.65 pH = 6.78
- 6.66 a) 12.6 b) 7.00 c) 1.3
- 6.67 Silver chromate S = $0.65 \times 10^{-4}M$; Molarity of $Ag^+ = 1.30 \times 10^{-4}M$
 Molarity of $CrO_4^{2-} = 0.65 \times 10^{-4}M$; Barium Chromate S = $1.1 \times 10^{-5}M$; Molarity of Ba^{2+} and CrO_4^{2-} each is $1.1 \times 10^{-5}M$; Ferric Hydroxide S = $1.39 \times 10^{-10}M$;
 Molarity of $Fe^{3+} = 1.39 \times 10^{-10}M$; Molarity of $[OH^-] = 4.17 \times 10^{-10}M$
 Lead Chloride S = $1.59 \times 10^{-2}M$; Molarity of $Pb^{2+} = 1.59 \times 10^{-2}M$
 Molarity of $Cl^- = 3.18 \times 10^{-2}M$; Mercurous Iodide S = $2.24 \times 10^{-10}M$;
 Molarity of $Hg_2^{2+} = 2.24 \times 10^{-10}M$ and molarity of $I^- = 4.48 \times 10^{-10}M$
- 6.68 Silver chromate is more soluble and the ratio of their molarities = 91.9
- 6.69 No precipitate
- 6.70 Silver benzoate is 3.317 times more soluble at lower pH
- 6.71 The highest molarity for the solution is $2.5 \times 10^{-9}M$
- 6.72 2.43 litre of water
- 6.73 Precipitation will take place in cadmium chloride solution

NOTES

© NCERT
not to be republished

Logarithms

TABLE I

N	0	1	2	3	4	5	6	7	8	9	1	2	3	4	5	6	7	8	9
10	0000	0043	0086	0128	0170						5	9	13	17	21	26	30	34	38
						0212	0253	0294	0334	0374	4	8	12	16	20	24	28	32	36
11	0414	0453	0492	0531	0569						4	8	12	16	20	23	27	31	35
						0607	0645	0682	0719	0755	4	7	11	15	18	22	26	29	33
12	0792	0828	0864	0899	0934						3	7	11	14	18	21	25	28	32
						0969	1004	1038	1072	1106	3	7	10	14	17	20	24	27	31
13	1139	1173	1206	1239	1271						3	6	10	13	16	19	23	26	29
						1303	1335	1367	1399	1430	3	7	10	13	16	19	22	25	29
14	1461	1492	1523	1553	1584						3	6	9	12	15	19	22	25	28
						1614	1644	1673	1703	1732	3	6	9	12	14	17	20	23	26
15	1761	1790	1818	1847	1875						3	6	9	11	14	17	20	23	26
						1903	1931	1959	1987	2014	3	6	8	11	14	17	19	22	25
16	2041	2068	2095	2122	2148						3	6	8	11	14	16	19	22	24
						2175	2201	2227	2253	2279	3	5	8	10	13	16	18	21	23
17	2304	2330	2355	2380	2405						3	5	8	10	13	15	18	20	23
						2430	2455	2480	2504	2529	3	5	8	10	12	15	17	20	22
18	2553	2577	2601	2625	2648						2	5	7	9	12	14	17	19	21
						2672	2695	2718	2742	2765	2	4	7	9	11	14	16	18	21
19	2788	2810	2833	2856	2878						2	4	7	9	11	13	16	18	20
						2900	2923	2945	2967	2989	2	4	6	8	11	13	15	17	19
20	3010	3032	3054	3075	3096	3118	3139	3160	3181	3201	2	4	6	8	11	13	15	17	19
21	3222	3243	3263	3284	3304	3324	3345	3365	3385	3404	2	4	6	8	10	12	14	16	18
22	3424	3444	3464	3483	3502	3522	3541	3560	3579	3598	2	4	6	8	10	12	14	15	17
23	3617	3636	3655	3674	3692	3711	3729	3747	3766	3784	2	4	6	7	9	11	13	15	17
24	3802	3820	3838	3856	3874	3892	3909	3927	3945	3962	2	4	5	7	9	11	12	14	16
25	3979	3997	4014	4031	4048	4065	4082	4099	4116	4133	2	3	5	7	9	10	12	14	15
26	4150	4166	4183	4200	4216	4232	4249	4265	4281	4298	2	3	5	7	8	10	11	13	15
27	4314	4330	4346	4362	4378	4393	4409	4425	4440	4456	2	3	5	6	8	9	11	13	14
28	4472	4487	4502	4518	4533	4548	4564	4579	4594	4609	2	3	5	6	8	9	11	12	14
29	4624	4639	4654	4669	4683	4698	4713	4728	4742	4757	1	3	4	6	7	9	10	12	13
30	4771	4786	4800	4814	4829	4843	4857	4871	4886	4900	1	3	4	6	7	9	10	11	13
31	4914	4928	4942	4955	4969	4983	4997	5011	5024	5038	1	3	4	6	7	8	10	11	12
32	5051	5065	5079	5092	5105	5119	5132	5145	5159	5172	1	3	4	5	7	8	9	11	12
33	5185	5198	5211	5224	5237	5250	5263	5276	5289	5302	1	3	4	5	6	8	9	10	12
34	5315	5328	5340	5353	5366	5378	5391	5403	5416	5428	1	3	4	5	6	8	9	10	11
35	5441	5453	5465	5478	5490	5502	5514	5527	5539	5551	1	2	4	5	6	7	9	10	11
36	5563	5575	5587	5599	5611	5623	5635	5647	5658	5670	1	2	4	5	6	7	8	10	11
37	5682	5694	5705	5717	5729	5740	5752	5763	5775	5786	1	2	3	5	6	7	8	9	10
38	5798	5809	5821	5832	5843	5855	5866	5877	5888	5899	1	2	3	5	6	7	8	9	10
39	5911	5922	5933	5944	5955	5966	5977	5988	5999	6010	1	2	3	4	5	7	8	9	10
40	6021	6031	6042	6053	6064	6075	6085	6096	6107	6117	1	2	3	4	5	6	8	9	10
41	6128	6138	6149	6160	6170	6180	6191	6201	6212	6222	1	2	3	4	5	6	7	8	9
42	6232	6243	6253	6263	6274	6284	6294	6304	6314	6325	1	2	3	4	5	6	7	8	9
43	6335	6345	6355	6365	6375	6385	6395	6405	6415	6425	1	2	3	4	5	6	7	8	9
44	6435	6444	6454	6464	6474	6484	6493	6503	6513	6522	1	2	3	4	5	6	7	8	9
45	6532	6542	6551	6561	6471	6580	6590	6599	6609	6618	1	2	3	4	5	6	7	8	9
46	6628	6637	6646	6656	6665	6675	6684	6693	6702	6712	1	2	3	4	5	6	7	7	8
47	6721	6730	6739	6749	6758	6767	6776	6785	6794	6803	1	2	3	4	5	5	6	7	8
48	6812	6821	6830	6839	6848	6857	6866	6875	6884	6893	1	2	3	4	4	5	6	7	8
49	6902	6911	6920	6928	6937	6946	6955	6964	6972	6981	1	2	3	4	4	5	6	7	8

Logarithms

TABLE 1 (Continued)

N	0	1	2	3	4	5	6	7	8	9	1	2	3	4	5	6	7	8	9
50	6990	6998	7007	7016	7024	7033	7042	7050	7059	7067	1	2	3	3	4	5	6	7	8
51	7076	7084	7093	7101	7110	7118	7126	7135	7143	7152	1	2	3	3	4	5	6	7	8
52	7160	7168	7177	7185	7193	7202	7210	7218	7226	7235	1	2	2	3	4	5	6	7	7
53	7243	7251	7259	7267	7275	7284	7292	7300	7308	7316	1	2	2	3	4	5	6	6	7
54	7324	7332	7340	7348	7356	7364	7372	7380	7388	7396	1	2	2	3	4	5	6	6	7
55	7404	7412	7419	7427	7435	7443	7451	7459	7466	7474	1	2	2	3	4	5	5	6	7
56	7482	7490	7497	7505	7513	7520	7528	7536	7543	7551	1	2	2	3	4	5	5	6	7
57	7559	7566	7574	7582	7589	7597	7604	7612	7619	7627	1	2	2	3	4	5	5	6	7
58	7634	7642	7649	7657	7664	7672	7679	7686	7694	7701	1	1	2	3	4	4	5	6	7
59	7709	7716	7723	7731	7738	7745	7752	7760	7767	7774	1	1	2	3	4	4	5	6	7
60	7782	7789	7796	7803	7810	7818	7825	7832	7839	7846	1	1	2	3	4	4	5	6	6
61	7853	7860	7768	7875	7882	7889	7896	7903	7910	7917	1	1	2	3	4	4	5	6	6
62	7924	7931	7938	7945	7952	7959	7966	7973	7980	7987	1	1	2	3	3	4	5	6	6
63	7993	8000	8007	8014	8021	8028	8035	8041	8048	8055	1	1	2	3	3	4	5	5	6
64	8062	8069	8075	8082	8089	8096	8102	8109	8116	8122	1	1	2	3	3	4	5	5	6
65	8129	8136	8142	8149	8156	8162	8169	8176	8182	8189	1	1	2	3	3	4	5	5	6
66	8195	8202	8209	8215	8222	8228	8235	8241	8248	8254	1	1	2	3	3	4	5	5	6
67	8261	8267	8274	8280	8287	8293	8299	8306	8312	8319	1	1	2	3	3	4	5	5	6
68	8325	8331	8338	8344	8351	8357	8363	8370	8376	8382	1	1	2	3	3	4	4	5	6
69	8388	8395	8401	8407	8414	8420	8426	8432	8439	8445	1	1	2	2	3	4	4	5	6
70	8451	8457	8463	8470	8476	8482	8488	8494	8500	8506	1	1	2	2	3	4	4	5	6
71	8513	8519	8525	8531	8537	8543	8549	8555	8561	8567	1	1	2	2	3	4	4	5	5
72	8573	8579	8585	8591	8597	8603	8609	8615	8621	8627	1	1	2	2	3	4	4	5	5
73	8633	8639	8645	8651	8657	8663	8669	8675	8681	8686	1	1	2	2	3	4	4	5	5
74	8692	8698	8704	8710	8716	8722	8727	8733	8739	8745	1	1	2	2	3	4	4	5	5
75	8751	8756	8762	8768	8774	8779	8785	8791	8797	8802	1	1	2	2	3	3	4	5	5
76	8808	8814	8820	8825	8831	8837	8842	8848	8854	8859	1	1	2	2	3	3	4	5	5
77	8865	8871	8876	8882	8887	8893	8899	8904	8910	8915	1	1	2	2	3	3	4	4	5
78	8921	8927	8932	8938	8943	8949	8954	8960	8965	8971	1	1	2	2	3	3	4	4	5
79	8976	8982	8987	8993	8998	9004	9009	9015	9020	9025	1	1	2	2	3	3	4	4	5
80	9031	9036	9042	9047	9053	9058	9063	9069	9074	9079	1	1	2	2	3	3	4	4	5
81	9085	9090	9096	9101	9106	9112	9117	9122	9128	9133	1	1	2	2	3	3	4	4	5
82	9138	9143	9149	9154	9159	9165	9170	9175	9180	9186	1	1	2	2	3	3	4	4	5
83	9191	9196	9201	9206	9212	9217	9222	9227	9232	9238	1	1	2	2	3	3	4	4	5
84	9243	9248	9253	9258	9263	9269	9274	9279	9284	9289	1	1	2	2	3	3	4	4	5
85	9294	9299	9304	9309	9315	9320	9325	9330	9335	9340	1	1	2	2	3	3	4	4	5
86	9345	9350	9355	9360	9365	9370	9375	9380	9385	9390	1	1	2	2	3	3	4	4	5
87	9395	9400	9405	9410	9415	9420	9425	9430	9435	9440	0	1	1	2	2	3	3	4	4
88	9445	9450	9455	9460	9465	9469	9474	9479	9484	9489	0	1	1	2	2	3	3	4	4
89	9494	9499	9504	9509	9513	9518	9523	9528	9533	9538	0	1	1	2	2	3	3	4	4
90	9542	9547	9552	9557	9562	9566	9571	9576	9581	9586	0	1	1	2	2	3	3	4	4
91	9590	9595	9600	9605	9609	9614	9619	9624	9628	9633	0	1	1	2	2	3	3	4	4
92	9638	9643	9647	9652	9657	9661	9666	9671	9675	9680	0	1	1	2	2	3	3	4	4
93	9685	9689	9694	9699	9703	9708	9713	9717	9722	9727	0	1	1	2	2	3	3	4	4
94	9731	9736	9741	9745	9750	9754	9759	9763	9768	9773	0	1	1	2	2	3	3	4	4
95	9777	9782	9786	9791	9795	9800	9805	9809	9814	9818	0	1	1	2	2	3	3	4	4
96	9823	9827	9832	9836	9841	9845	9850	9854	9859	9863	0	1	1	2	2	3	3	4	4
97	9868	9872	9877	9881	9886	9890	9894	9899	9903	9908	0	1	1	2	2	3	3	4	4
98	9912	9917	9921	9926	9930	9934	9939	9943	9948	9952	0	1	1	2	2	3	3	4	4
99	9956	9961	9965	9969	9974	9978	9983	9987	9991	9996	0	1	1	2	2	3	3	4	4

AntiLogarithms

TABLE II

N	0	1	2	3	4	5	6	7	8	9	1	2	3	4	5	6	7	8	9
.00	1000	1002	1005	1007	1009	1012	1014	1016	1019	1021	0	0	1	1	1	1	2	2	2
.01	1023	1026	1028	1030	1033	1035	1038	1040	1042	1045	0	0	1	1	1	1	2	2	2
.02	1047	1050	1052	1054	1057	1059	1062	1064	1067	1069	0	0	1	1	1	1	2	2	2
.03	1072	1074	1076	1079	1081	1084	1086	1089	1091	1094	0	0	1	1	1	1	2	2	2
.04	1096	1099	1102	1104	1107	1109	1112	1114	1117	1119	0	1	1	1	1	2	2	2	2
.05	1122	1125	1127	1130	1132	1135	1138	1140	1143	1146	0	1	1	1	1	2	2	2	2
.06	1148	1151	1153	1156	1159	1161	1164	1167	1169	1172	0	1	1	1	1	2	2	2	2
.07	1175	1178	1180	1183	1186	1189	1191	1194	1197	1199	0	1	1	1	1	2	2	2	2
.08	1202	1205	1208	1211	1213	1216	1219	1222	1225	1227	0	1	1	1	1	2	2	2	3
.09	1230	1233	1236	1239	1242	1245	1247	1250	1253	1256	0	1	1	1	1	2	2	2	3
.10	1259	1262	1265	1268	1271	1274	1276	1279	1282	1285	0	1	1	1	1	2	2	2	3
.11	1288	1291	1294	1297	1300	1303	1306	1309	1312	1315	0	1	1	1	2	2	2	2	3
.12	1318	1321	1324	1327	1330	1334	1337	1340	1343	1346	0	1	1	1	2	2	2	2	3
.13	1349	1352	1355	1358	1361	1365	1368	1371	1374	1377	0	1	1	1	2	2	2	3	3
.14	1380	1384	1387	1390	1393	1396	1400	1403	1406	1409	0	1	1	1	2	2	2	3	3
.15	1413	1416	1419	1422	1426	1429	1432	1435	1439	1442	0	1	1	1	2	2	2	3	3
.16	1445	1449	1452	1455	1459	1462	1466	1469	1472	1476	0	1	1	1	2	2	2	3	3
.17	1479	1483	1486	1489	1493	1496	1500	1503	1507	1510	0	1	1	1	2	2	2	3	3
.18	1514	1517	1521	1524	1528	1531	1535	1538	1542	1545	0	1	1	1	2	2	2	3	3
.19	1549	1552	1556	1560	1563	1567	1570	1574	1578	1581	0	1	1	1	2	2	3	3	3
.20	1585	1589	1592	1596	1600	1603	1607	1611	1614	1618	0	1	1	1	2	2	3	3	3
.21	1622	1626	1629	1633	1637	1641	1644	1648	1652	1656	0	1	1	2	2	2	3	3	3
.22	1660	1663	1667	1671	1675	1679	1683	1687	1690	1694	0	1	1	2	2	2	3	3	3
.23	1698	1702	1706	1710	1714	1718	1722	1726	1730	1734	0	1	1	2	2	2	3	3	4
.24	1738	1742	1746	1750	1754	1758	1762	1766	1770	1774	0	1	1	2	2	2	3	3	4
.25	1778	1782	1786	1791	1795	1799	1803	1807	1811	1816	0	1	1	2	2	2	3	3	4
.26	1820	1824	1828	1832	1837	1841	1845	1849	1854	1858	0	1	1	2	2	3	3	3	4
.27	1862	1866	1871	1875	1879	1884	1888	1892	1897	1901	0	1	1	2	2	3	3	3	4
.28	1905	1910	1914	1919	1923	1928	1932	1936	1941	1945	0	1	1	2	2	3	3	4	4
.29	1950	1954	1959	1963	1968	1972	1977	1982	1986	1991	0	1	1	2	2	3	3	4	4
.30	1995	2000	2004	2009	2014	2018	2023	2028	2032	2037	0	1	1	2	2	3	3	4	4
.31	2042	2046	2051	2056	2061	2065	2070	2075	2080	2084	0	1	1	2	2	3	3	4	4
.32	2089	2094	2099	2104	2109	2113	2118	2123	2128	2133	0	1	1	2	2	3	3	4	4
.33	2138	2143	2148	2153	2158	2163	2168	2173	2178	2183	0	1	1	2	2	3	3	4	4
.34	2188	2193	2198	2203	2208	2213	2218	2223	2228	2234	1	1	2	2	3	3	4	4	5
.35	2239	2244	2249	2254	2259	2265	2270	2275	2280	2286	1	1	2	2	3	3	4	4	5
.36	2291	2296	2301	2307	2312	2317	2323	2328	2333	2339	1	1	2	2	3	3	4	4	5
.37	2344	2350	2355	2360	2366	2371	2377	2382	2388	2393	1	1	2	2	3	3	4	4	5
.38	2399	2404	2410	2415	2421	2427	2432	2438	2443	2449	1	1	2	2	3	3	4	4	5
.39	2455	2460	2466	2472	2477	2483	2489	2495	2500	2506	1	1	2	2	3	3	4	4	5
5																			
.40	2512	2518	2523	2529	2535	2541	2547	2553	2559	2564	1	1	2	2	3	4	4	5	5
.41	2570	2576	2582	2588	2594	2600	2606	2612	2618	2624	1	1	2	2	3	4	4	5	5
.42	2630	2636	2642	2649	2655	2661	2667	2673	2679	2685	1	1	2	2	3	4	4	5	6
.43	2692	2698	2704	2710	2716	2723	2729	2735	2742	2748	1	1	2	3	3	4	4	5	6
.44	2754	2761	2767	2773	2780	2786	2793	2799	2805	2812	1	1	2	3	3	4	4	5	6
.45	2818	2825	2831	2838	2844	2851	2858	2864	2871	2877	1	1	2	3	3	4	4	5	6
.46	2884	2891	2897	2904	2911	2917	2924	2931	2938	2944	1	1	2	3	3	4	4	5	6
.47	2951	2958	2965	2972	2979	2985	2992	2999	3006	3013	1	1	2	3	3	4	4	5	6
.48	3020	3027	3034	3041	3048	3055	3062	3069	3076	3083	1	1	2	3	3	4	4	5	6
.49	3090	3097	3105	3112	3119	3126	3133	3141	3148	3155	1	1	2	3	3	4	4	5	6

AntiLogarithms

TABLE II (Continued)

N	0	1	2	3	4	5	6	7	8	9	1	2	3	4	5	6	7	8	9
.50	3162	3170	3177	3184	3192	3199	3206	3214	3221	3228	1	1	2	3	4	4	5	6	7
.51	3236	3243	3251	3258	3266	3273	3281	3289	3296	3304	1	2	2	3	4	5	5	6	7
.52	3311	3319	3327	3334	3342	3350	3357	3365	3373	3381	1	2	2	3	4	5	5	6	7
.53	3388	3396	3404	3412	3420	3428	3436	3443	3451	3459	1	2	2	3	4	5	6	6	7
.54	3467	3475	3483	3491	3499	3508	3516	3524	3532	3540	1	2	2	3	4	5	6	6	7
.55	3548	3556	3565	3573	3581	3589	3597	3606	3614	3622	1	2	2	3	4	5	6	7	7
.56	3631	3639	3648	3656	3664	3673	3681	3690	3698	3707	1	2	3	3	4	5	6	7	8
.57	3715	3724	3733	3741	3750	3758	3767	3776	3784	3793	1	2	3	3	4	5	6	7	8
.58	3802	3811	3819	3828	3837	3846	3855	3864	3873	3882	1	2	3	4	4	5	6	7	8
.59	3890	3899	3908	3917	3926	3936	3945	3954	3963	3972	1	2	3	4	5	5	6	7	8
.60	3981	3990	3999	4009	4018	4027	4036	4046	4055	4064	1	2	3	4	5	6	6	7	8
.61	4074	4083	4093	4102	4111	4121	4130	4140	4150	4159	1	2	3	4	5	6	7	8	9
.62	4169	4178	4188	4198	4207	4217	4227	4236	4246	4256	1	2	3	4	5	6	7	8	9
.63	4266	4276	4285	4295	4305	4315	4325	4335	4345	4355	1	2	3	4	5	6	7	8	9
.64	4365	4375	4385	4395	4406	4416	4426	4436	4446	4457	1	2	3	4	5	6	7	8	9
.65	4467	4477	4487	4498	4508	4519	4529	4539	4550	4560	1	2	3	4	5	6	7	8	9
.66	4571	4581	4592	4603	4613	4624	4634	4645	4656	4667	1	2	3	4	5	6	7	9	10
.67	4677	4688	4699	4710	4721	4732	4742	4753	4764	4775	1	2	3	4	5	7	8	9	10
.68	4786	4797	4808	4819	4831	4842	4853	4864	4875	4887	1	2	3	4	6	7	8	9	10
.69	4898	4909	4920	4932	4943	4955	4966	4977	4989	5000	1	2	3	5	6	7	8	9	10
.70	5012	5023	5035	5047	5058	5070	5082	5093	5105	5117	1	2	4	5	6	7	8	9	11
.71	5129	5140	5152	5164	5176	5188	5200	5212	5224	5236	1	2	4	5	6	7	8	10	11
.72	5248	5260	5272	5284	5297	5309	5321	5333	5346	5358	1	2	4	5	6	7	9	10	11
.73	5370	5383	5395	5408	5420	5433	5445	5458	5470	5483	1	3	4	5	6	8	9	10	11
.74	5495	5508	5521	5534	5546	5559	5572	5585	5598	5610	1	3	4	5	6	8	9	10	12
.75	5623	5636	5649	5662	5675	5689	5702	5715	5728	5741	1	3	4	5	7	8	9	10	12
.76	5754	5768	5781	5794	5808	5821	5834	5848	5861	5875	1	3	4	5	7	8	9	11	12
.77	5888	5902	5916	5929	5943	5957	5970	5984	5998	6012	1	3	4	5	7	8	10	11	12
.78	6026	6039	6053	6067	6081	6095	6109	6124	6138	6152	1	3	4	6	7	8	10	11	13
.79	6166	6180	6194	6209	6223	6237	6252	6266	6281	6295	1	3	4	6	7	9	10	11	13
.80	6310	6324	6339	6353	6368	6383	6397	6412	6427	6442	1	3	4	6	7	9	10	12	13
.81	6457	6471	6486	6501	6516	6531	6546	6561	6577	6592	2	3	5	6	8	9	11	12	14
.82	6607	6622	6637	6653	6668	6683	6699	6714	6730	6745	2	3	5	6	8	9	11	12	14
.83	6761	6776	6792	6808	6823	6839	6855	6871	6887	6902	2	3	5	6	8	9	11	13	14
.84	6918	6934	6950	6966	6982	6998	7015	7031	7047	7063	2	3	5	6	8	10	11	13	15
.85	7079	7096	7112	7129	7145	7161	7178	7194	7211	7228	2	3	5	7	8	10	12	13	15
.86	7244	7261	7278	7295	7311	7328	7345	7362	7379	7396	2	3	5	7	8	10	12	13	15
.87	7413	7430	7447	7464	7482	7499	7516	7534	7551	7568	2	3	5	7	9	10	12	14	16
.88	7586	7603	7621	7638	7656	7674	7691	7709	7727	7745	2	4	5	7	9	11	12	14	16
.89	7762	7780	7798	7816	7834	7852	7870	7889	7907	7925	2	4	5	7	9	11	13	14	16
.90	7943	7962	7980	7998	8017	8035	8054	8072	8091	8110	2	4	6	7	9	11	13	15	17
.91	8128	8147	8166	8185	8204	8222	8241	8260	8279	8299	2	4	6	8	9	11	13	15	17
.92	8318	8337	8356	8375	8395	8414	8433	8453	8472	8492	2	4	6	8	10	12	14	15	17
.93	8511	8531	8551	8570	8590	8610	8630	8650	8670	8690	2	4	6	8	10	12	14	16	18
.94	8710	8730	8750	8770	8790	8810	8831	8851	8872	8892	2	4	6	8	10	12	14	16	18
.95	8913	8933	8954	8974	8995	9016	9036	9057	9078	9099	2	4	6	8	10	12	15	17	19
.96	9120	9141	9162	9183	9204	9226	9247	9268	9290	9311	2	4	6	8	11	13	15	17	19
.97	9333	9354	9376	9397	9419	9441	9462	9484	9506	9528	2	4	7	9	11	13	15	17	20
.98	9550	9572	9594	9616	9638	9661	9683	9705	9727	9750	2	4	7	9	11	13	16	18	20
.99	9772	9795	9817	9840	9863	9886	9908	9931	9954	9977	2	5	7	9	11	14	16	18	20

NOTES

© NCERT
not to be republished

NOTES

© NCERT
not to be republished